

THE **RPLC-SERIES** IS A SINGLE ACTING LOAD RETURN PANCAKE LOCKING COLLAR CYLINDER. IT IS A COMPACT DESIGN THAT FEATURES A THREADED PISTON ROD AND LOCK RING.

When the lock ring is screwed down and engaged with the cylinder body, the load can be held mechanically for extended periods. Hoses and pumps can be removed until lowering is required. These cylinders are ideally suited to bridge construction and maintenance. All RPLC-Series cylinders feature a hard chrome bore for maximum corrosion resistance and a special coating on the piston rod and lock ring to resist corrosion and abrasion. Integral tilt saddle and an oil overflow port which restricts piston stroke is standard on all models.



Model Number	Cylinder Capacity ton* / kN		Stroke (mm)	Cylinder Effective Area (cm ²)	Oil Capacity (cm ³)	A Collapsed Height (mm)	B Extended Height (mm)	D Outside Diameter (mm)
RPLC-602	60	606	50	86.6	433	125	175	140
RPLC-1002	100	1,027	50	146.8	733	137	187	175
RPLC-1602	160	1,619	45	231.3	1,040	148	193	220
RPLC-2002	200	1,999	45	285.6	1,285	155	200	245
RPLC-2502	250	2,567	45	366.8	1,650	159	204	275
RPLC-4002	400	3,916	45	559.5	2,516	178	223	350
RPLC-5002	500	5,114	45	730.6	3,286	192	237	400

* Nominal Cylinder Capacity in ton - see kN values for actual capacity

HARDENED GROOVED TILT SADDLE

on all models to prevent piston rod damage

LOW FRICTION COATING

on piston rod and lock nut enhances corrosion resistance

HARD CHROME PLATED BORE

for maximum corrosion resistance and cylinder life

OVERFLOW PORT

on the piston rod ensures cylinder is not over extended

LOCK RING

holds load mechanically

POWDER COATED FINISH

enhances appearance and reduces corrosion

PARKER

industry standard high flow coupling for compatibility



CAPACITY

60 - 500 ton

STROKE

45 - 50 mm

MAXIMUM OPERATING PRESSURE

700 bar

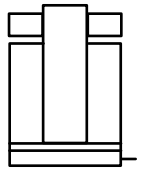

B

CYLINDERS

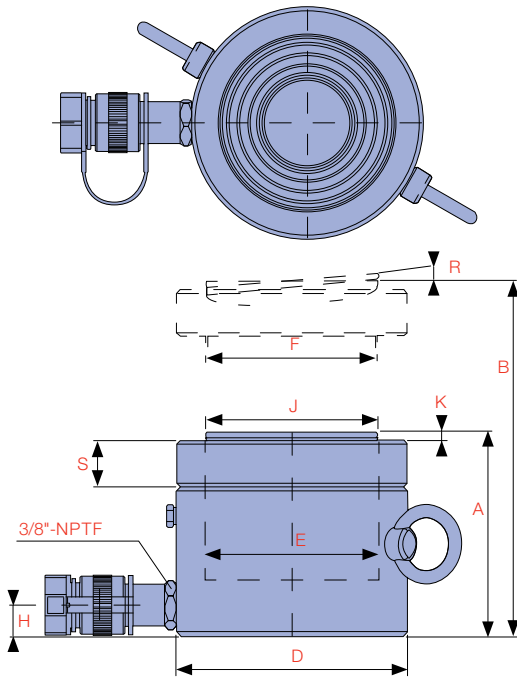

CAUTION...

RPLC-Series pancake locking collar cylinders must be used with the base fully engaged and on a firm stable jacking surface.

E Cylinder Bore Diameter (mm)	F **Piston Rod Diameter (mm)	H Base to Advance Port (mm)	J Standard Saddle Diameter (mm)	K Saddle Protrusion from Piston Rod (mm)	R Tilt Saddle Maximum Angle	S Lock Ring Height (mm)	Weight (kg)	Model Number	Handle Type
105.0	TR104x4	19	96	6	5°	28	15	RPLC-602	◆
136.7	TR136x6	21	126	8	5°	31	26	RPLC-1002	◆
171.6	TR171x6	27	160	9	5°	40	44	RPLC-1602	◆
190.7	TR190x6	30	180	10	5°	43	57	RPLC-2002	◆
216.1	TR216x6	32	200	11	5°	44	74	RPLC-2502	◆
266.9	TR266x6	39	250	11	4°	55	134	RPLC-4002	◆
305.0	TR305x6	48	290	10	3°	62	189	RPLC-5002	◆

HANDLE TYPES: ♠ WELDED ◆ EYEBOLT ♥ REMOVABLE STRAP HANDLE ♣ THREAD

** TR is a metric trapezoidal thread