

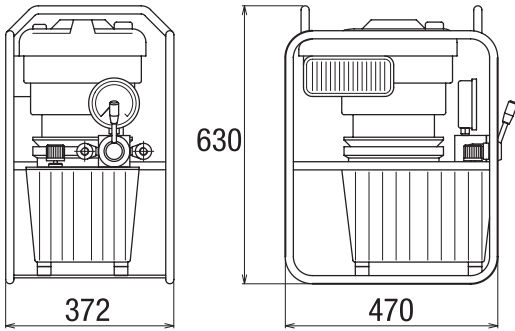

PPM2014 HYDRAULIC HIGH PRESSURE PETROL PUMP

This powerful 4 stroke high pressure hydraulic pump is equipped with a protection cage that makes it easier to move and lift, protecting it in construction sites. With a large 10 litre aluminium reservoir it is capable of use with a wide range of equipment. Reduced maintenance and designed to last.



FEATURES

- Powerful Honda GXV 2.6 KW 4 stroke petrol engine
- Aluminium 10 litre oil reservoir
- Rugged tubular protection cage
- 4 way 3 position double acting manual directional valve with internal check valve
- Fast 4.5 litre minute first stage oil flow and 1.8 litre minute at 700 bar (10,000PSI)

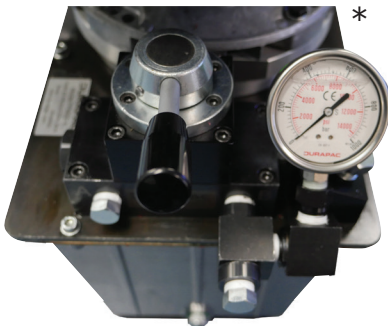

Model No	Motor Type/ Brand	Hyd Pressure (bar)	Hyd Reservoir Capacity (L)	Motor Fuel	Motor Power (kW/HP)	RPM	Dimensions Outside Frame (mm) LxWxH	Weight inc oil & frame (kg)
PPM2014	4-Stroke / Honda	700 (10,000PSI)	10	Petrol	2.6 / 3.5	3,000	470x372x630	47

***Image Includes Optional Accessories - Pressure Gauge and Gauge Adaptors**