

DURAPAC
ENGINEERED FOR RELIABILITY

Instruction Manual

Single Acting Hydrostatic Power Unit
Model – PHS-300



Maximum Operating Pressure – 300 bar



This is a safety alert symbol. It is used to alert you to potential personal injury hazards. Obey all safety messages that follow this symbol to avoid injury or death

1.0 Product Information

DURAPAC – Hydrostatic Power Units are engineered to meet Industrial Standards for Performance and Safety. The PHS-300 is an air operated hydrostatic power unit that is designed to work with either water or oil. These self-contained units are compact and robust and operate at 300 bar. They come complete with air filter, regulator, lubricator, air/hydraulic pressure gauges, outlet pressure connection block, release valve and interconnecting pipework. The equipment is mounted inside a stainless steel frame and the pump is ideally suited for hydrostatic testing, operation of hydraulic valve actuators, clamping and tensioning tools.

- Strainer filter supplied on fluid inlet
- Filter, regulator and lubricator are supplied on air inlet
- Air pressure gauge to monitor working air pressure
- Liquid filled hydrostatic pressure gauge with scale in bar/psi
- Stainless steel base and frame resists corrosion and allows for easy handling
- Water/oil outlets fitted with a 3/8”-18 NPTF needle valve to allow greater control

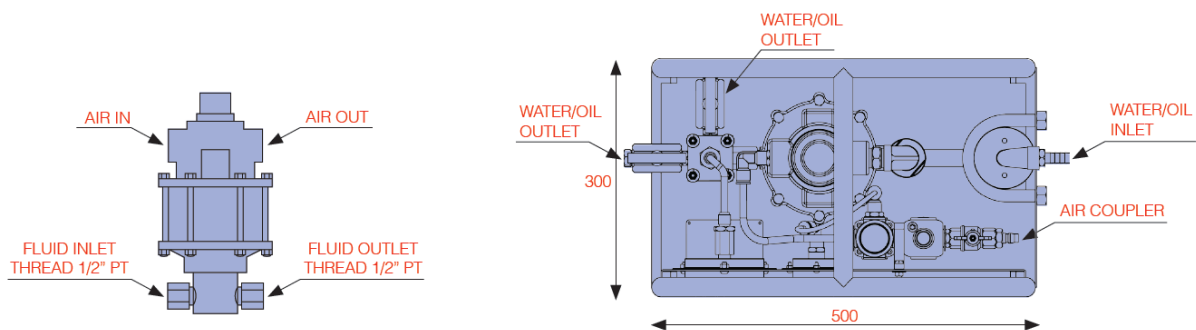

Figure 1 – PHS-300 Components

Special skill, knowledge and training may be required for a specific task and the product may not be suitable for all jobs. The user must ultimately make the decision regarding suitability of the product for any given task and assume the responsibility of safety for all in the work area. Contact a Durapac representative if you are unsure of your power units suitability for a particular application.

2.0 Receiving Instructions

It is recommended prior to use that an inspection be done by qualified personnel and that any missing or damaged parts, decals, warning/safety labels or signs are replaced with Durapac authorised replacement parts only. Any power unit that appears to be damaged in any way, is worn, leaking or operates abnormally should be removed from service immediately until such time as repairs can be made. Any power unit that has been or suspected to have been subject to a shock load should be removed from service immediately until inspected by a Durapac authorised service centre. Owners and operators of this equipment should be aware that the use and subsequent repair of this equipment may require specialised training and knowledge.

3.0 Safety

Save these instructions. For your safety, read and understand the information contained within. The owner and operator should have an understanding of this product and safe operating procedures before attempting to use this product. Instructions and safety information should be conveyed in the operator's native language before use of this product is authorised. Make certain that the operator thoroughly understands the inherent dangers associated with the use and misuse of the product. If any doubt exists as to the safe and proper use of this product as outlined in this factory authorised manual, remove from service immediately.

**DANGER:**

- To avoid personal injury keep hands and feet away from work area during operation
- **Do NOT** handle pressurised hoses. Escaping fluid under pressure can penetrate the skin causing serious injury. If fluid is injected under the skin, see a doctor immediately
- Stay clear of loads supported by hydraulics. A cylinder, when used as a load lifting device, should never be used as a load holding device. After the load has been raised or lowered, it must always be supported mechanically

**WARNING:**

- The system operating pressure must not exceed the pressure rating of the lowest rated component in the system. Install pressure gauges in the system to monitor operating pressure. It is your window to what is happening in the system
- Always wear appropriate personal protective equipment (PPE) when operating hydraulic equipment. The operator must take precaution against injury due to failure of the tool or work piece(s)
- **Do NOT** hold or stand directly in line with any hydraulic connections while pressurising
- **Do NOT** attempt to disconnect hydraulic connections under pressure. Release all line pressure before disconnecting hoses
- All personnel must be clear before lowering load or depressurising the system
- **Do NOT** attempt to lift a load weighing more than the capacity of the cylinder

**IMPORTANT:**

- If at any stage, the safety related decals become hard to read, these must be replaced
- Minimum age of the operator must be 18 years. The operator must have read and understood all instructions, safety issues, cautions and warnings before starting to operate the equipment. The operator is responsible for this activity towards other persons
- **Do NOT** lift hydraulic equipment by the hoses or couplers. Use the carrying handle or other means of safe transport
- Hydraulic equipment must only be serviced by a qualified hydraulic technician. For repair service, contact the Durapac authorised service centre in your area. To protect your warranty, use only high quality hydraulic fluid

**CAUTION:**

- **KEEP HYDRAULIC EQUIPMENT AWAY FROM FLAMES AND HEAT.** Hydraulic fluid can ignite and burn. Excessive heat will soften packings and seals, resulting in fluid leaks. Heat also weakens hose materials and packings. For optimum performance do not expose equipment to temperatures of 65°C (150°F) or higher. Protect all equipment from weld spatter
- No alteration should be made to this device

3.1 Hydraulic Power Units

- **Do** use a gauge or other load measuring instrument to verify load
- **Do NOT** exceed the rated capacity of the power unit or any equipment in the system. Burst hazard exists if connection pressure exceeds rated pressure
- **Do NOT** operate the system with bent or damaged couplers or damaged threads
- **Do NOT** subject the power unit and its components to shock loads
- Use only Durapac approved accessories and components
- **Do NOT** connect to an application which can return more fluid to the reservoir than the power unit reservoir can hold
- **Do NOT** connect power unit to a hydraulic system that is powered by another pump

3.2 Hydraulic Hoses & Fluid Transmission Lines

- Avoid short runs of straight line tubing. Straight line runs do not provide for expansion and contraction due to pressure and/or temperature changes
- Reduce stress in tube lines. Long tubing runs should be supported by brackets or clips. Before operating the power unit, connections should be tightened securely and leak-free. Over tightening can cause premature thread failure or high pressure fittings to burst
- Should a hydraulic hose ever rupture, burst or need to be disconnected, immediately shut off the power unit and release all pressure. Never attempt to grasp a leaking pressurised hose with your hands. The force of escaping hydraulic fluid can inflict injury
- **Do NOT** subject the hose to potential hazard such as fire, sharp objects, extreme heat or cold or heavy impact
- **Do NOT** allow the hose to kink, twist, curl, crush, cut or bend so tightly that the fluid flow within the hose is blocked or reduced. Periodically inspect the hose for wear
- Hose material and coupler seals must be compatible with the hydraulic fluid used. Hoses also must not come in contact with corrosive materials such as battery acid, creosote-impregnated objects and wet paint. Never paint a coupler or hose

FAILURE TO HEED THESE WARNINGS MAY RESULT IN PERSONAL INJURY AS WELL AS PROPERTY DAMAGE.

4.0 Installation

 **IMPORTANT:** Always secure threaded port connections with high grade, non-hardening pipe thread sealant. Teflon tape can be used if only one layer of tape is used and it is applied carefully, two threads back, to prevent the tape from being introduced into hydraulic system, which could cause jamming of precision-fit parts

 Use only good quality filtered water. Use of anything other than good quality water will void warranty and damage the power unit

- 4.1 Familiarise yourself with the specifications and illustrations in this owner’s manual. Know your power unit, its limitations and how it operates before attempting to use. Refer to the specification chart below or if in doubt, contact a Durapac representative.

Model No.	Compression Ratio	Output Oil/Water cm ³ /per stroke	Pressure Rating (bar)	Working Air Pressure (bar)	Water/Oil Outlet Thread	Weight (kg)
PHS-300	1:60	6.4	300	5-7	3/8"-18 NPTF	25

- 4.2 Connect fluid output port to suitable fittings and the application.
- 4.3 Connect water or oil source to pump inlet prior to operating air driven power unit.
- 4.4 Check all system fittings and connections to be sure they are tight and leak free.
- 4.5 Use one of the check valves on the pump to bleed any air from the system – Air can accumulate in the hydraulic system during the initial setup.

5.0 Operation



IMPORTANT:

- **Do NOT** operate a power unit that is disconnected from application. If operated in this condition, the hose and connections will become pressurised. This increases burst hazard. Damage may occur to power unit and its components
- The air pressure regulator will stop the power unit when it reaches its maximum working pressure

5.1 Before Using the Power Unit

- 5.1.1 Select one of the two outputs marked as “Water/Oil Output” as the Release Valve.
- 5.1.2 Check all system fittings and connections to be sure they are tight and leak free.
- 5.1.3 Connect the water/oil outlet to a suitable external reservoir.
- 5.1.4 Close air input valve.
- 5.1.5 Turn the power unit’s release valve to an open position.
- 5.1.6 Pull “Pressure Adjust” up to ensure zero pressure.

5.2 Power Unit Operation

- 5.2.1 Slowly open Air Input. Power unit will begin working.

- 5.2.2 As water/oil begins to flow from the release valve, tighten release valve and pressure will begin to rise.
- 5.2.3 Turn the Pressure Adjustment knob on the air regulator and use the Hydraulic Gauge to monitor pressure. Reduce the air pressure to zero bar/psi to slow and eventually stop the power unit.
- 5.2.4 Stop the power unit by closing the Air Input and slowly opening the release valve. The Hydraulic Gauge will fall to zero.
- 5.2.5 Lock the air regulator by pushing down the Pressure Adjustment knob.

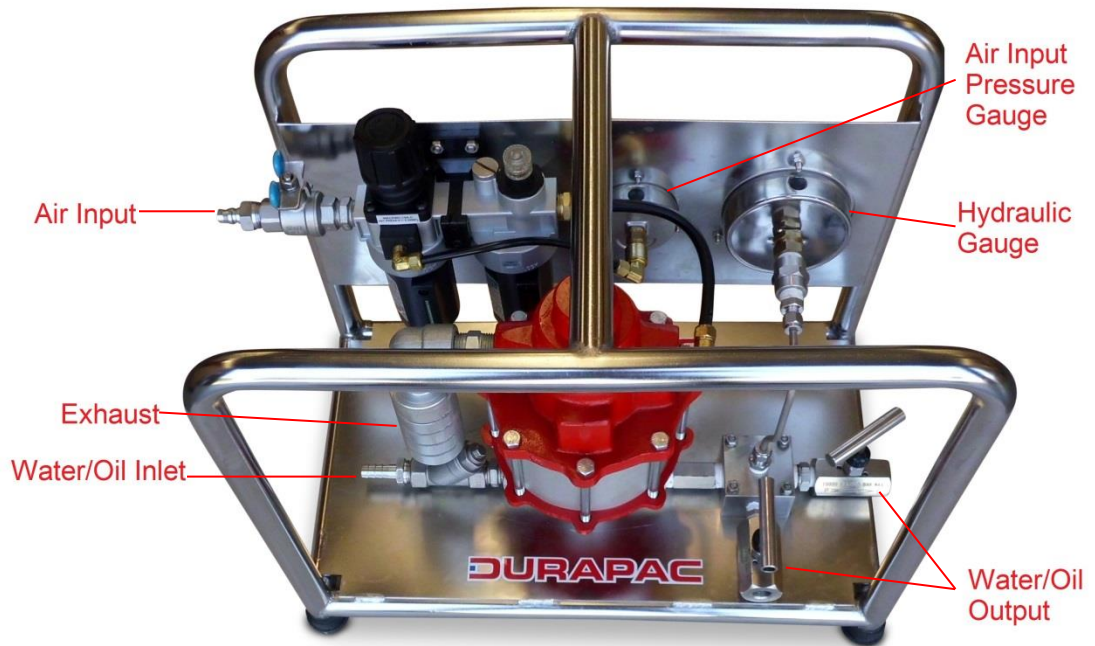

Figure 2 – PHS-300 Components

6.0 Maintenance



IMPORTANT:

- Equipment must only be serviced by a qualified hydraulic technician. For repair service, contact your local Durapac authorised service centre
- Damage to hydraulic hoses may not be detected during visual inspections. For this reason, Durapac recommends that hydraulic hoses be replaced on a regular basis
- Tighten connections as needed. Use non-hardening pipe thread compound when servicing connections

Dirt, sand, etc. will quickly ruin any hydraulic system. Ensure that couplings are clean and free of foreign matter. After each use, clean couplings and attach dust caps.

Maintenance is required when wear or leakage is noticed. Periodically inspect all components to detect any problem that may require service and maintenance.

6.1 Storage

- 6.1.1 When not in use, depressurise and disconnect the hydraulic power unit from the application.
- 6.1.2 Wipe clean thoroughly and store in a clean, dry environment. Avoid temperature extremes.
- 6.1.3 Shield power unit with a protective cover.

7.0 Troubleshooting

Problem	Cause	Solution
Pump loses pressure	Leaking system components	<ul style="list-style-type: none"> • Repair or replace as necessary
Pump not delivering fluid	Low fluid level in reservoir	<ul style="list-style-type: none"> • Check fluid level
	Worn seats	<ul style="list-style-type: none"> • Repair seats • Replace pump body
Pump does not reach rated capacity	Low fluid level in reservoir	<ul style="list-style-type: none"> • Check fluid level
	Leaking system components	<ul style="list-style-type: none"> • Repair or replace as necessary
	Fluid leaking past inlet or outlet checks	<ul style="list-style-type: none"> • Repair inlet or outlet checks • Replace high pressure piston seal
Cylinder piston will not extend	Loose couplers	<ul style="list-style-type: none"> • Tighten couplers
	Low fluid level in pump reservoir	<ul style="list-style-type: none"> • Fill and bleed the system
	Leaking cylinder seals	<ul style="list-style-type: none"> • Replace worn seals. Look for excessive contamination or wear
Cylinder piston extends only partially	Low fluid level in pump reservoir	<ul style="list-style-type: none"> • Fill and bleed the system
	Load above capacity of system	<ul style="list-style-type: none"> • Use correct equipment
Cylinder piston extends slower than normal	Loose couplers	<ul style="list-style-type: none"> • Tighten couplers
	Restricted hydraulic line or fitting	<ul style="list-style-type: none"> • Clean and replace if damaged
	Pump not operating correctly	<ul style="list-style-type: none"> • Check pump's operating instructions • Repair or replace as necessary
	Low fluid level in pump reservoir	<ul style="list-style-type: none"> • Fill and bleed the system
Cylinder does not hold pressure	Leaky connection	<ul style="list-style-type: none"> • Clean, reseal with thread sealant, and tighten connection
	Leaking cylinder seals	<ul style="list-style-type: none"> • Replace worn seals • Look for excessive contamination or wear • Replace contaminated fluid
	Pump or valve not operating correctly	<ul style="list-style-type: none"> • Repair or replace as necessary
Cylinder will not retract or retracts slower than normal	Closed pump release valve	<ul style="list-style-type: none"> • Open pump release valve
	Loose couplers	<ul style="list-style-type: none"> • Tighten couplers
	Blocked hydraulic lines	<ul style="list-style-type: none"> • Clean and flush lines
	Weak or broken retraction springs	<ul style="list-style-type: none"> • Send to a Durapac authorised service centre for repair
	Internally damaged cylinder	<ul style="list-style-type: none"> • Send to a Durapac authorised service centre for repair
	Pump reservoir too full	<ul style="list-style-type: none"> • Drain fluid to correct level

8.0 Parts Breakdown and List

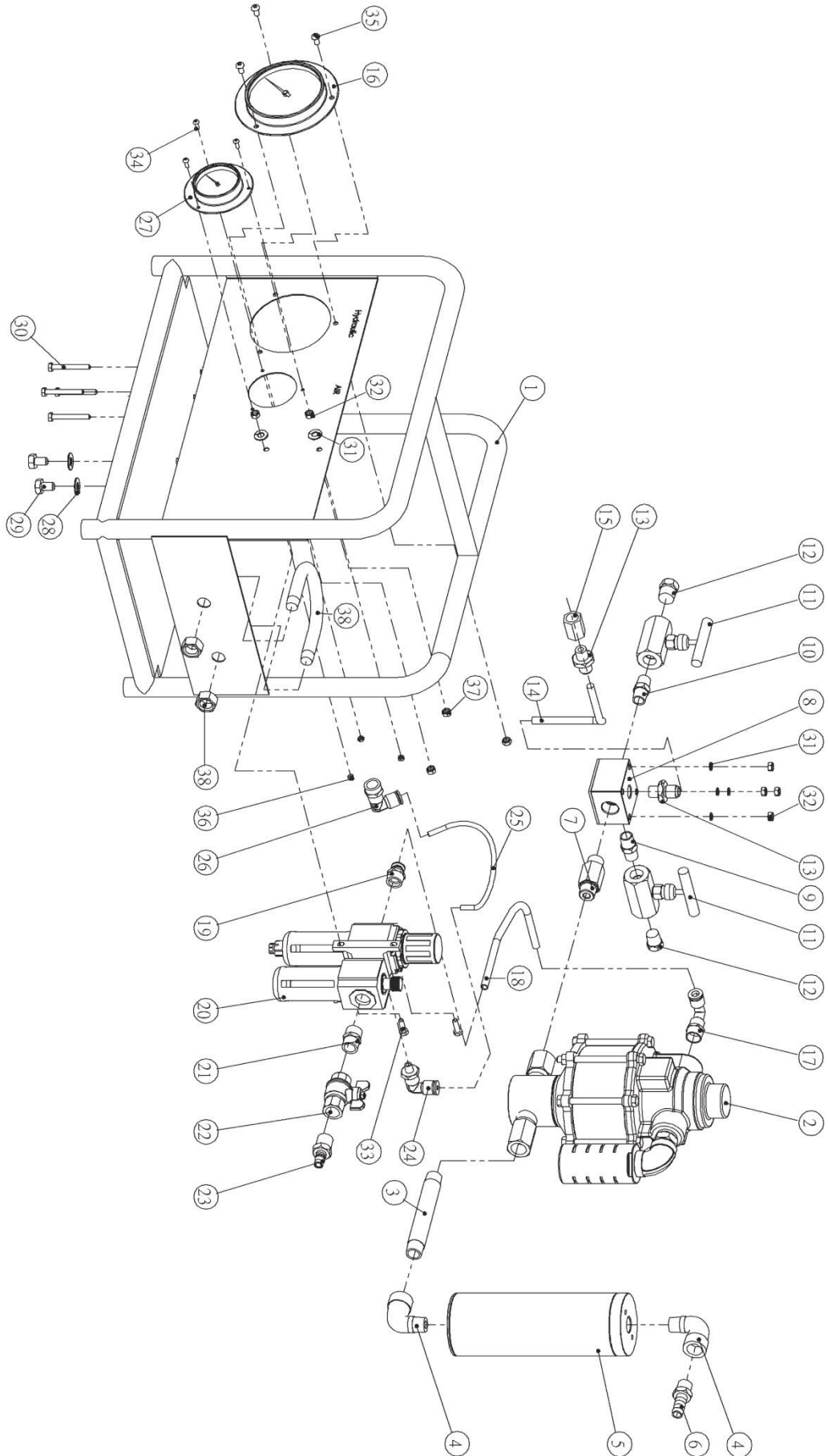

Item	Description	Part No.	Qty	Item	Description	Part No.	Qty	Item	Description	Part No.	Qty
1	Frame	ZAM1631	1	14	Steel tube	ZAM1691	1	27	Air pressure gauge	ZAM1704	1
2	Pump	ZAM1793	1	15	Coupling	ZAM1692	1	28	Spring washer	ZAM1705	2
3	Nipple	ZAM1680	1	16	Hydraulic pressure gauge	ZAM1693	1	29	Bolt	ZAM1706	2
4	Elbow	ZAM1681	2	17	Elbow	ZAM1694	1	30	Bolt	ZAM1707	4
5	Filter	ZAM1682	1	18	PU tube	ZAM1695	1	31	Spring washer	ZAM1708	6
6	1/2" water coupler male	ZAM1683	1	19	Connector	ZAM1696	1	32	Nut	ZAM1709	6
7	Nipple	ZAM1684	1	20	Air unit	ZAM1697	1	33	Bolt	ZAM1710	2
8	Gauge accessories	ZAM1685	1	21	1/2" coupling	ZAM1698	1	34	Bolt	ZAM1711	3
9	3/8" coupling	ZAM1686	1	22	1/2" wing valve	ZAM1699	1	35	Bolt	ZAM1712	3
10	Adaptor	ZAM1687	1	23	1/2" air coupler male	ZAM1700	1	36	Nut	ZAM1713	3
11	Needle valve	ZAM1688	2	24	Male coupler	ZAM1701	1	37	Nut	ZAM1714	3
12	3/8" PT bolt	ZAM1689	2	25	Nylon tube	ZAM1702	1	38	U bolt & nut	ZAM1715	1
13	Adaptor	ZAM1690	2	26	Female coupler	ZAM1703	1				

8.1 Pump Breakdown and Parts List

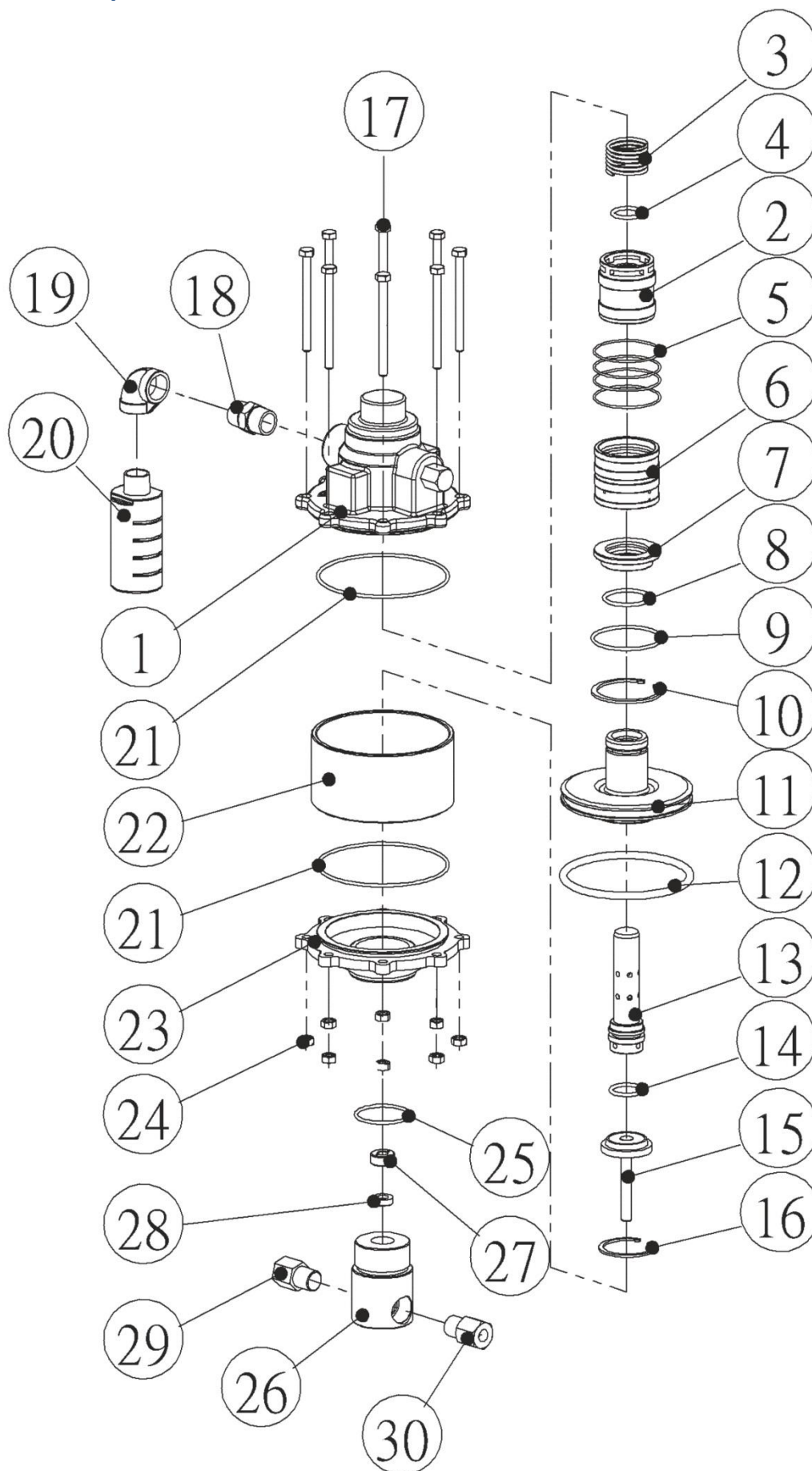

Item	Description	Part No.	Qty	Item	Description	Part No.	Qty	Item	Description	Part No.	Qty
1	Upper pump housing	ZAM1716	1	11	Air piston	ZAM1726	1	21	O-ring*	ZAM1736	2
2	Aluminium piston	ZAM1717	1	12	O-ring*	ZAM1727	1	22	Aluminium barrel	ZAM1737	1
3	Spring	ZAM1718	1	13	Piston	ZAM1728	1	23	Lower pump housing	ZAM1738	1
4	O-ring*	ZAM1719	1	14	O-ring*	ZAM1729	1	24	Nut	ZAM1739	8
5	O-ring*	ZAM1720	4	15	Hydraulic piston	ZAM1794	1	25	O-ring*	ZAM1740	1
6	Aluminium bush	ZAM1721	1	16	C type ring	ZAM1731	1	26	Pump seat	ZAM1795	1
7	Aluminium cap	ZAM1722	1	17	Bolt	ZAM1732	8	27	Nut	ZAM1796	1
8	O-ring*	ZAM1723	1	18	Nipple	ZAM1733	1	28	Seal*	ZAM1797	1
9	O-ring*	ZAM1724	1	19	Elbow	ZAM1734	1	29	Input bolt assembly*	ZAM1744	1
10	C type ring	ZAM1725	1	20	Silencer	ZAM1735	1	30	Output bolt assembly	ZAM1745	1
									Repair kit	ZAM1798	1

Items marked with a * are contained within a standard Repair Kit.
 Serial, item and model numbers need to be quoted when ordering parts.