



Instruction Manual

Manual Hydraulic Bottle Jack with Air Pump
Model – DBJ-20A





This is a safety alert symbol. It is used to alert you to potential personal injury hazards. Obey all safety messages that follow this symbol to avoid injury or death

1.0 Product Information

DURAPAC – Bottle Jacks are engineered to meet Industrial Standards for Performance and Safety. The DBJ Series of bottle jacks are a premium range ideally suited to most industrial lifting and pushing applications. The DBJ-20A model also includes a fast motion air pump for greater actuation and comes complete with a 3 piece saddle set (16, 45 and 80 mm saddle heights).

Special skill, knowledge and training may be required for a specific task and the product may not be suitable for all jobs. The user must ultimately make the decision regarding suitability of the product for any given task and assume the responsibility of safety for all in the work area. Contact a Durapac representative if you are unsure of your bottle jacks suitability for a particular application.

2.0 Receiving Instructions

Open the packing/storage/carrying case and confirm that the jack, air line, trigger valve and the three piece handle are present and undamaged.

It is recommended prior to use that an inspection be done by qualified personnel and that any missing or damaged parts (including handle), decals, warning/safety labels or signs are replaced with Durapac authorised replacement parts only. Any jack that appears to be damaged in any way, is worn, leaking or operates abnormally should be removed from service immediately until such time as repairs can be made. Any jack that has been or suspected to have been subject to a shock load should be removed from service immediately until inspected by a Durapac authorised service centre. Owners and operators of this equipment should be aware that the use and subsequent repair of this equipment may require specialised training and knowledge.

3.0 Safety

Save these instructions. For your safety, read and understand the information contained within. The owner and operator should have an understanding of this product and safe operating procedures before attempting to use this product. Instructions and safety information should be conveyed in the operator's native language before use of this product is authorised. Make certain that the operator thoroughly understands the inherent dangers associated with the use and misuse of the product. If any doubt exists as to the safe and proper use of this product as outlined in this factory authorised manual, remove from service immediately.



DANGER:

- To avoid personal injury keep hands and feet away from work area during operation
- **Do NOT** handle pressurized hoses. Escaping oil under pressure can penetrate the skin causing serious injury. If oil is injected under the skin, see a doctor immediately
- Stay clear of loads supported by hydraulics. A cylinder, when used as a load lifting device, should never be used as a load holding device. After the load has been raised or lowered, it must always be supported mechanically

**WARNING:**

- The system operating pressure must not exceed the pressure rating of the lowest rated component in the system. Install pressure gauges in the system to monitor operating pressure. It is your window to what is happening in the system
- Always wear appropriate personal protective equipment (PPE) when operating hydraulic equipment. The operator must take precaution against injury due to failure of the tool or work piece(s)
- **Do NOT** hold or stand directly in line with any hydraulic connections while pressurising
- **Do NOT** attempt to disconnect hydraulic connections under pressure. Release all line pressure before disconnecting hoses
- All personnel must be clear before lowering load or depressurising the system
- **Do NOT** attempt to lift a load weighing more than the capacity of the jack

**IMPORTANT:**

- If at any stage, the safety related decals become hard to read, these must be replaced
- Minimum age of the operator must be 18 years. The operator must have read and understood all instructions, safety issues, cautions and warnings before starting to operate the equipment. The operator is responsible for this activity towards other persons
- **Do NOT** lift hydraulic equipment by the hoses or couplers. Use the carrying handle or other means of safe transport
- Hydraulic equipment must only be serviced by a qualified hydraulic technician. For repair service, contact the Durapac authorised service centre in your area. To protect your warranty, use only high quality hydraulic oil

**CAUTION:**

- **KEEP HYDRAULIC EQUIPMENT AWAY FROM FLAMES AND HEAT.** Hydraulic fluid can ignite and burn. Excessive heat will soften packings and seals, resulting in fluid leaks. Heat also weakens hose materials and packings. For optimum performance do not expose equipment to temperatures of 65°C (150°F) or higher. Protect all equipment from weld spatter
- No alteration should be made to this device

3.1 Hydraulic Bottle Jacks

- **Do NOT** under any circumstances tamper with the adjustment of the jacks internal relief valve screw. To do so may cause the jack to fail
- **Do NOT** use in unstable or hazardous positions
- Use the jack on solid and level surfaces capable of carrying the load. An unstable load may cause the jack or load to slip
- Keep non-essential personnel at a safe distance when using jack
- **Do NOT** lift people or loads with people on them

- Ensure that the jack is undamaged and in good working order. **Do NOT** use the jack if it is damaged
- This guide can't cover every situation; ensure safety is the number one priority when using this jack

3.2 If Used on a Vehicle

- Ensure that the vehicle to be raised is unoccupied, that the hand brake is firmly applied and Park (Auto) or 1st Gear (Manual) is engaged
- Ensure that the vehicle wheels are chocked to prevent movement in both directions
- Check that there is sufficient space around the vehicle to allow for tilting
- Ensure that jacking the vehicle will not result in the spillage of fuel, battery acid or other dangerous substances or movement
- Place the jack under a specified jacking point. See the vehicle hand book for details
- **Do NOT** allow anyone inside, or on, the vehicle to be jacked
- Raise the vehicle only as far as is necessary
- **Do NOT** work on, or under, a vehicle which is supported only by a jack (or jacks) - always use axle stands

FAILURE TO HEED THESE WARNINGS MAY RESULT IN PERSONAL INJURY AS WELL AS PROPERTY DAMAGE.

4.0 Installation

4.1 Familiarise yourself with the specifications and illustrations in this owner's manual. Know your bottle jack, its limitations and how it operates before attempting to use. Refer to the specification chart below or if in doubt, contact a Durapac representative.

Model No.	Operation	Capacity (ton)	Stroke (mm)	Collapsed Height (mm)	Extended Height (mm)	Piston Rod Diameter (mm)	Base Dimensions - L x W (mm)	Auxillary Height (mm)	Air Pressure Range (kgf/cm ²)	Net Weight (kg)
DBJ-20A	Air/Manual	20	150	235	385	50	128 x 238	16, 45, 80	8-12	14.5

4.2 Connect the compressor to air valve (6) air line (Figures 1 & 2).

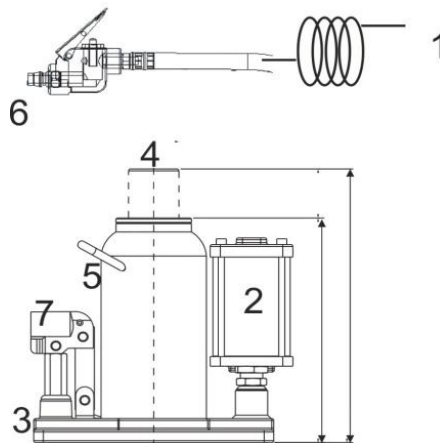

Figures 1 & 2 – DBJ-20A Components

- 4.3 Interlock the three handle sections. Note the reduced diameter 'working' end section and the rounded end hand grip section.
- 4.4 Check oil level:
 - 4.4.1 Open the release valve (3) with the handle (not more than two turns) and press down on the saddle (4) to ensure the piston is fully down.
 - 4.4.2 Remove oil filler plug (5). Oil should be level with the bottom of the filler hole.
 - 4.4.3 Adjust level as necessary and replace the plug.
- 4.5 Remove air from the system – Air can accumulate in the hydraulic system during the initial setup or after prolonged use, causing the cylinder to respond slowly or in an unstable manner. Should removal of air from pump be required, please follow the steps in 6.2 – Bleeding Air from the System in the Maintenance Section.
- 4.6 Lubricate:
 - 4.6.1 Oil the pivots of the manual pump mechanism and the screw thread of the saddle post.
 - 4.6.2 Put two or three drops of air tool oil into the inlet of the air valve (6).
 - 4.6.3 Connect to air supply and operate for three seconds to distribute lubricant.

5.0 Operation

5.1 Raising

-  Always support the load by mechanical means before working on or under the load
- 5.1.1 Close the release valve (clockwise) with the jacking handle.
 - 5.1.2 Position the jack so that the saddle is under the load point. If necessary, screw up the saddle to just below the jacking point. **Do NOT** use the handle in the release valve to move the jack, or damage could occur.
 - 5.1.3 Press the air valve trigger to raise. Release trigger to stop. Alternatively, use the handle to operate the manual pump.

5.2 Lowering

- 5.2.1 Check beneath the load for any obstructions and remove any mechanical supports.
- 5.2.2 **Slowly** open the release valve (counter clockwise) with the handle. Control the rate of descent by gradually opening or closing the valve.

Note: The release valve should not be closed abruptly (except in an emergency) since this shock loads the hydraulic system.

6.0 Maintenance



IMPORTANT:

- Check oil level regularly
- Use only good quality hydraulic fluid. **Do NOT** use brake fluid, transmission fluid, turbine oil, motor oil, alcohol, glycerine etc. Use of anything other than good quality hydraulic oil will void warranty and damage the jack, hose, and application. We recommend Durapac Hydraulic Oil or equivalent
- Equipment must only be serviced by a qualified hydraulic technician. For repair service, contact your local Durapac authorised service centre
- Damage to hydraulic hoses may not be detected during visual inspections. For this reason, Durapac recommends that hydraulic hoses be replaced on a regular basis

Maintenance is required when wear or leakage is noticed. Periodically inspect all components to detect any problem that may require service and maintenance.

6.1 Adding Hydraulic Fluid

 **WARNING:** Always add oil with cylinders fully retracted (or extended, if pull cylinders) or the system will contain more oil than the reservoir can hold

- 6.1.1 Depressurise and disconnect hydraulic hose from application.
- 6.1.2 Open release valve (3) with handle, (not more than two turns) and press down on saddle (4) to ensure piston is fully down (as shown in *Figure 1 & 2*).
- 6.1.3 Remove oil filler plug (5).
- 6.1.4 Use a small funnel to fill the reservoir level with the bottom of the filler hole.
- 6.1.5 Bleed air from system if necessary.
- 6.1.6 Wipe up any spilled fluid and replace the plug.

6.2 Bleeding Air from the System

- 6.2.1 Repeat Steps 6.1.1 to 6.1.3 (above).
- 6.2.2 Actuate pump handle 12 times. Air will be released into the jack reservoir.
- 6.2.3 Recheck oil level after removing air.
- 6.2.4 Wipe up any spilled fluid and replace the plug.

6.3 Changing Hydraulic Fluid

 For best results, change fluid once a year or every 300 hours of use

- 6.3.1 Repeat Steps 6.1.1 to 6.1.3 (above).
- 6.3.2 Pour used fluid into a sealable container.
- 6.3.3 Repeat Steps 6.1.4 to 6.1.6 (above).
- 6.3.4 Dispose of fluid in accordance with local regulations.

6.4 Storage

- 6.4.1 When not in use, depressurise and disconnect the hydraulic pump from the application.
- 6.4.2 Store the jack with the piston and the manual pump sockets fully down.
- 6.4.3 Thoroughly wipe clean and store in a clean, dry environment. Avoid temperature extremes.

7.0 Troubleshooting

Problem	Cause	Solution
Jack will not lift the load	Release valve not fully closed	<ul style="list-style-type: none"> • Firmly close valve
	No oil or oil level low	<ul style="list-style-type: none"> • Top-up to correct level
	Air in system	<ul style="list-style-type: none"> • Bleed system as described in Maintenance Section – 6.2
	Load is above capacity of system	<ul style="list-style-type: none"> • Use correct equipment
Jack will not lift smoothly or to the full height	Oil level low	<ul style="list-style-type: none"> • Top-up to correct level
	Air in system	<ul style="list-style-type: none"> • Bleed system as described in Maintenance Section – 6.2
	Sticking or binding cylinder	<ul style="list-style-type: none"> • Check for dirt, gummy deposits or leaks. Check for misalignment, worn parts or defective seals
Jack advances slowly	Air in system	<ul style="list-style-type: none"> • Bleed system as described in Maintenance Section – 6.2
	Leaking seals	<ul style="list-style-type: none"> • Replace seals
Jack advances but does not hold the load	The pump check valve is not working correctly	<ul style="list-style-type: none"> • Clean/replace check valve
	Leaking cylinder seals	<ul style="list-style-type: none"> • Replace seals
	Overload valve leaking or not adjusted correctly	<ul style="list-style-type: none"> • Replace/adjust overload valve
Jack leaks oil	Worn or damaged seals	<ul style="list-style-type: none"> • Replace seals
Jack will not retract or retracts slowly	Closed release valve	<ul style="list-style-type: none"> • Open release valve
	Internally damaged cylinder	<ul style="list-style-type: none"> • Send jack to an authorised Durapac service centre for repair
	Reservoir too full	<ul style="list-style-type: none"> • Drain oil to correct level

8.0 Parts Breakdown and List

8.1 DBJ-20A Parts Breakdown

*****Supersedes all previous versions*****

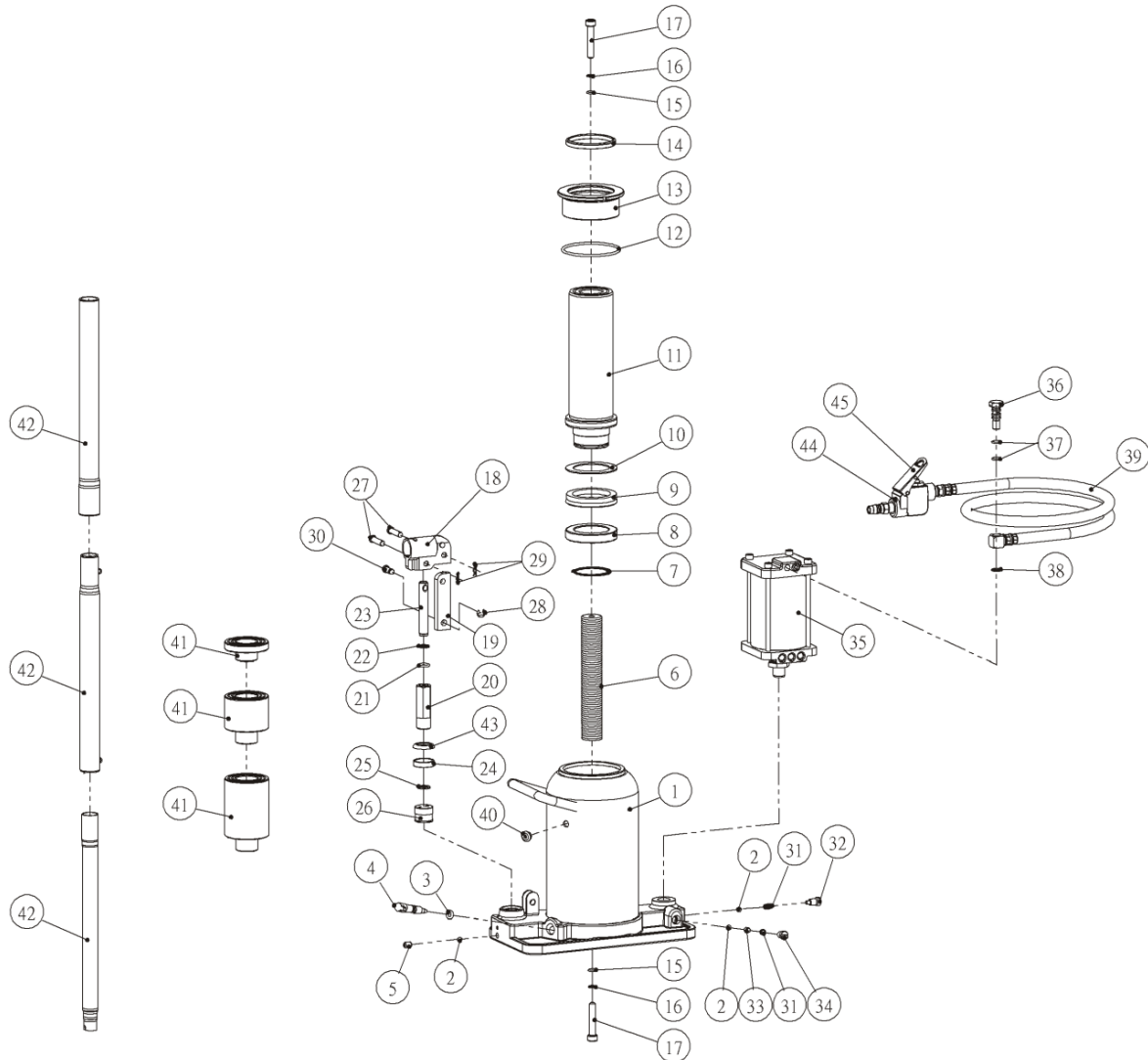

Item Description	Part No.	Qty	Item Description	Part No.	Qty	Item Description	Part No.	Qty
1 Body	ZAM1147	1	17 Bolt*	ZAM1163	2	33 Block	ZAM1179	1
2 Steel ball	ZAM1148	3	18 Paint rocker set	ZAM1164	1	34 Bolt	ZAM1180	1
3 O-ring*	ZAM1149	1	19 Connect shaft	ZAM1165	1	35 Air pump	ZAM1181	1
4 Release bolt	ZAM1150	1	20 Piston rod	ZAM1166	1	36 Bolt	ZAM1182	1
5 Bolt	ZAM1151	1	21 O-ring*	ZAM1167	1	37 O-ring*	ZAM1183	2
6 Spring	ZAM1152	1	22 Back-up ring*	ZAM1168	1	38 Washer	ZAM1184	1
7 Stop ring	ZAM1153	1	23 Rod	ZAM1169	1	39 Air input	ZAM1185	1
8 Piston	ZAM1154	1	24 Hex. Seal	ZAM1170	1	40 Gas plug*	ZAM1186	1
9 Seal*	ZAM1155	1	25 Aluminium washer	ZAM1171	1	41 Saddle (3 piece set)	ZAM1187	1
10 Back-up ring*	ZAM1156	1	26 Manual one way valve	ZAM1172	1	42 Handle	ZAM1188	1
11 Piston rod	ZAM1157	1	27 Bolt-long	ZAM1173	2	43 Hex. Space	ZAM1189	1
12 O-ring*	ZAM1158	1	28 C type ring*	ZAM1174	1	44 Switch	ZAM1190	1
13 Stop ring	ZAM1159	1	29 Snap pin	ZAM1175	2	45 Pressure plate	ZAM1191	1
14 Wiper*	ZAM1160	1	30 Bolt-short	ZAM1176	1	Seal kit	ZAM1089	1
15 O-ring*	ZAM1160	2	31 Spring	ZAM1177	2			
16 Back-up ring*	ZAM1162	2	32 Bolt	ZAM1178	1			

8.2 DBJ-20A Air Pump

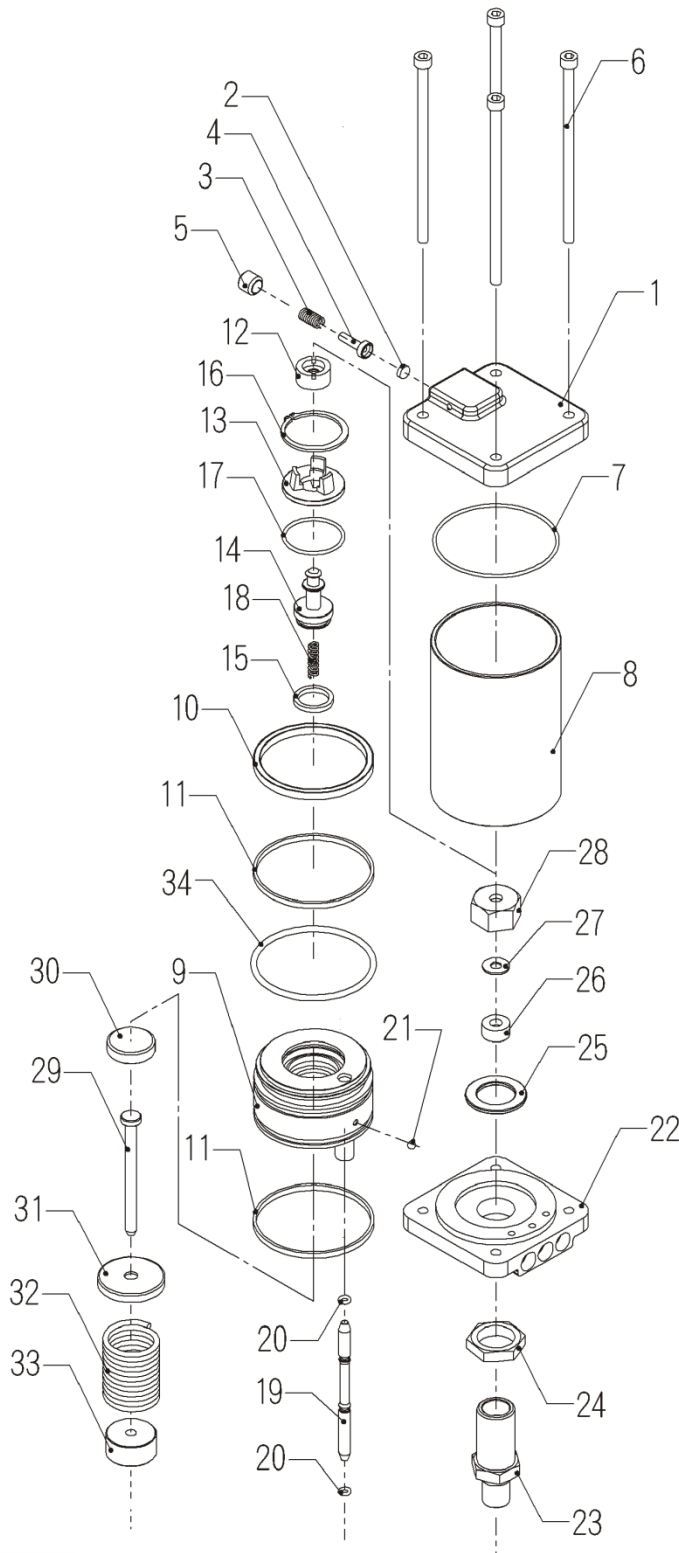

Item	Description	Part No.	Qty
1	Upper lid	ZAM1192	1
2	Rubber washer	ZAM1193	1
3	Spring	ZAM1194	1
4	CU valve handle	ZAM1195	1
5	Regulate bolt	ZAM1196	1
6	Bolt	ZAM1197	4
7	O-ring*	ZAM1198	1
8	Cylinder	ZAM1199	1
9	Piston rod	ZAM1200	1
10	Oil seal*	ZAM1201	1
11	Wearproof ring*	ZAM1202	2
12	Up. rubber washer	ZAM1203	1
13	Tripod	ZAM1204	1
14	Little column base	ZAM1205	1
15	Oil seal*	ZAM1206	1
16	C type ring	ZAM1207	1
17	O-ring*	ZAM1208	1
18	Spring	ZAM1209	1
19	Branch handle	ZAM1210	1
20	O-ring*	ZAM1211	2
21	Bolt	ZAM1212	1
22	Lower lid	ZAM1213	1
23	Oil pump	ZAM1214	1
24	Lower nut	ZAM1215	1
25	Spring washer	ZAM1216	1
26	Oil seal*	ZAM1217	1
27	CU washer	ZAM1218	1
28	Upper nut	ZAM1219	1
29	Oil pump axle	ZAM1220	1
30	Washer	ZAM1221	1
31	Spring lid	ZAM1222	1
32	Spring	ZAM1223	1
33	Axle lump	ZAM1224	1
34	O-ring	ZAM1225	1
	Seal kit	ZAM1226	1

Items marked with a * are contained within a standard seal kit.

Serial, model and part numbers need to be quoted when ordering parts.