



# Instruction Manual

Hydraulic Nut Splitter  
Model – DNS Series



**Maximum Operating Pressure – 700 bar**



This is a safety alert symbol. It is used to alert you to potential personal injury hazards. Obey all safety messages that follow this symbol to avoid injury or death

## 1.0 Product Information

DURAPAC – Hydraulic Nut Splitters are engineered to meet Industrial Standards for Performance and Safety. The DNS Series use a single-acting, hydraulic advance/spring return cylinder offering between 5 – 90 ton of force. All models can be driven by a 700 bar lightweight, single-acting, hand pump or power unit.

The unique angled-head design gives clearance to the body when operating on a flat surface. They are a compact design, capable of splitting nuts up to hardness HRc44 and are also suitable for use on Grade 2H high temperature nuts as used in the petrochemical industry. Each tool is supplied in a heavy duty moulded plastic storage case except DNS-6075 which comes with a wooden case.

- Durapac 700 bar single acting hydraulic pumps can operate these nut splitters
- Angled head design gives clearance to the body when operated on a flat surface
- Seven models of splitters available
- Single acting hydraulic advance/spring return cylinder
- Splitting blade is easily replaceable

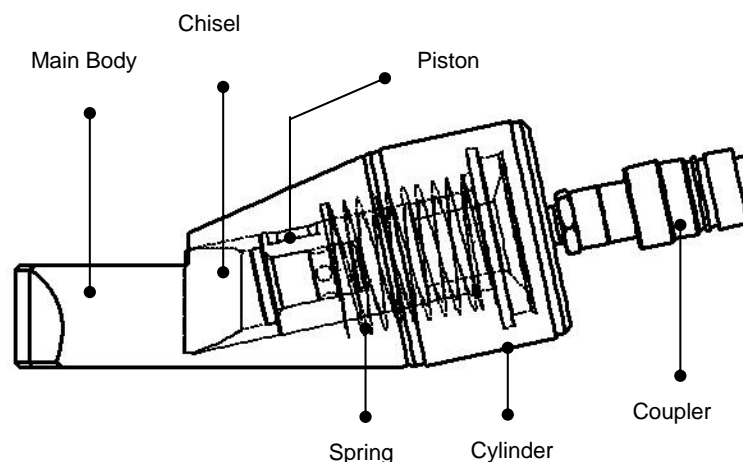

Figure 1 – Nut Splitter Subassembly

Special skill, knowledge and training may be required for a specific task and the product may not be suitable for all jobs. The user must ultimately make the decision regarding suitability of the product for any given task and assume the responsibility of safety for all in the work area. Contact a Durapac representative if you are unsure of your nut splitter's suitability for a particular application.

## 2.0 Receiving Instructions

It is recommended prior to use that an inspection be done by qualified personnel and that any missing or damaged parts, decals, warning/safety labels or signs are replaced with Durapac authorised replacement parts only. Any nut splitter that appears to be damaged in any way, is worn, leaking or operates abnormally should be removed from service immediately until such time as repairs can be made. Any nut splitter that has been or suspected to have been subject to a shock load should be removed from service immediately until inspected by a Durapac authorised service

centre. Owners and operators of this equipment should be aware that the use and subsequent repair of this equipment may require specialised training and knowledge.

### 3.0 Safety

Save these instructions. For your safety, read and understand the information contained within. The owner and operator should have an understanding of this product and safe operating procedures before attempting to use this product. Instructions and safety information should be conveyed in the operator's native language before use of this product is authorised. Make certain that the operator thoroughly understands the inherent dangers associated with the use and misuse of the product. If any doubt exists as to the safe and proper use of this product as outlined in this factory authorised manual, remove from service immediately.



#### **DANGER:**

- To avoid personal injury keep hands and feet away from work area during operation
- **Do NOT** handle pressurized hoses. Escaping oil under pressure can penetrate the skin causing serious injury. If oil is injected under the skin, see a doctor immediately
- Stay clear of loads supported by hydraulics. A cylinder, when used as a load lifting device, should never be used as a load holding device. After the load has been raised or lowered, it must always be blocked mechanically



#### **WARNING:**

- The system operating pressure must not exceed the pressure rating of the lowest rated component in the system. Install pressure gauges in the system to monitor operating pressure. It is your window to what is happening in the system
- Always wear protective gear when operating hydraulic equipment. The operator must take precaution against injury due to failure of the tool or work piece(s)
- **Do NOT** hold or stand directly in line with any hydraulic connections while pressurising
- **Do NOT** attempt to disconnect hydraulic connections under pressure. Release all line pressure before disconnecting hoses
- All personnel must be clear before lowering load or depressurising the system
- **Do NOT** attempt to lift a load weighing more than the capacity of the cylinder



#### **IMPORTANT:**

- If at any stage, the safety related decals become hard to read, these must be replaced
- Minimum age of the operator must be 18 years. The operator must have read and understood all instructions, safety issues, cautions and warnings before starting to operate the equipment. The operator is responsible for this activity towards other persons
- **Do NOT** lift hydraulic equipment by the hoses or couplers. Use the carrying handle or other means of safe transport
- Hydraulic equipment must only be serviced by a qualified hydraulic technician. For repair service, contact the Durapac authorised service centre in your area. To protect your warranty, use only high quality hydraulic oil

**CAUTION:**

- **KEEP HYDRAULIC EQUIPMENT AWAY FROM FLAMES AND HEAT.** Hydraulic fluid can ignite and burn. Excessive heat will soften packings and seals, resulting in fluid leaks. Heat also weakens hose materials and packings. For optimum performance do not expose equipment to temperatures of 65°C (150°F) or higher. Protect all equipment from weld spatter
- No alteration should be made to this device

### 3.1 Nut Splitters

- The user must be a qualified operator familiar with the correct operation, maintenance and use of nut splitters. Lack of knowledge in any of these areas can lead to personal injury
- Do not use this tool on glass, plastic, wood or any other materials which could shatter
- **Do NOT** operate the system with bent or damaged couplers or damaged threads
- **Do NOT** connect to an application which can return more oil to the reservoir than the pump reservoir can hold
- Use only Durapac approved accessories and components

### 3.2 Hydraulic Hoses & Fluid Transmission Lines

- Avoid short runs of straight line tubing. Straight line runs do not provide for expansion and contraction due to pressure and/or temperature changes
- Reduce stress in tube lines. Long tubing runs should be supported by brackets or clips. Before operating the pump, connections should be tightened securely and leak-free. Over tightening can cause premature thread failure or high pressure fittings to burst
- Should a hydraulic hose ever rupture, burst or need to be disconnected, immediately shut off the pump and release all pressure. Never attempt to grasp a leaking pressurised hose with your hands. The force of escaping hydraulic fluid can inflict injury
- **Do NOT** subject the hose to potential hazard such as fire, sharp objects, extreme heat or cold or heavy impact
- **Do NOT** allow the hose to kink, twist, curl, crush, cut or bend so tightly that the fluid flow within the hose is blocked or reduced. Periodically inspect the hose for wear
- Hose material and coupler seals must be compatible with the hydraulic fluid used. Hoses also must not come in contact with corrosive materials such as battery acid, creosote-impregnated objects and wet paint. Never paint a coupler or hose

**FAILURE TO HEED THESE WARNINGS MAY RESULT IN PERSONAL INJURY AS WELL AS PROPERTY DAMAGE.**

## 4.0 Installation



**IMPORTANT:** Always secure threaded port connections with high grade, non-hardening pipe thread sealant. Teflon tape can be used if only one layer of tape is used and it is applied

carefully, two threads back, to prevent the tape from being introduced into hydraulic system, which could cause jamming of precision-fit parts

- 4.1 Familiarise yourself with the specifications and illustrations in this owner’s manual. Know your nut splitter, its limitations and how it operates before attempting to use. Refer to the specification chart and dimension details below or if in doubt, contact a Durapac representative.

**Table 1– Specification chart**

Model No.	Bolt Range	Hex Nut Range (mm)	Capacity (ton)	Oil Capacity (cm <sup>3</sup> )	Dimensions (mm)			Weight (kg)	Spare Blade Model No.
					Length	Width	Height		
<b>DNS-1319</b>	M6-M12	10-19	<b>5</b>	13	170	40	48	1.2	<b>DNS-1319-4</b>
<b>DNS-1924</b>	M12-M16	19-24	<b>10</b>	21	191	54	62	2.0	<b>DNS-1924-4</b>
<b>DNS-2432</b>	M16-M22	24-32	<b>15</b>	58	222	64	72	3.0	<b>DNS-2432-4</b>
<b>DNS-3241</b>	M22-M27	32-41	<b>20</b>	88	244	75	88	4.4	<b>DNS-3241-4</b>
<b>DNS-4150</b>	M27-M33	41-50	<b>35</b>	153	288	94	105	8.2	<b>DNS-4150-4</b>
<b>DNS-5060</b>	M33-M39	50-60	<b>50</b>	233	318	106	128	11.8	<b>DNS-5060-4</b>
<b>DNS-6075</b>	M39-M48	60-75	<b>90</b>	492	393	156	181	34.1	<b>DNS-6075-4</b>

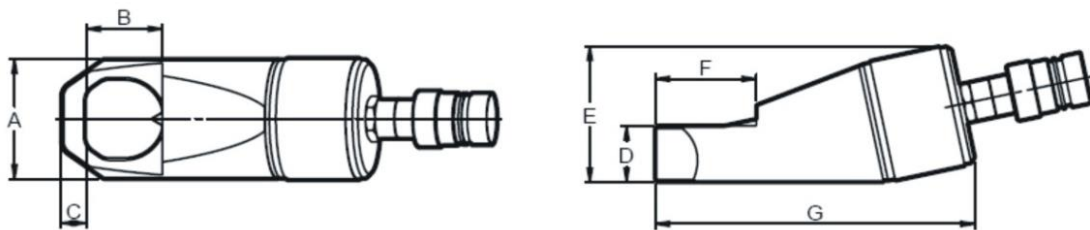

*Figure 2 – Dimensions*

**Table 2 – Dimensions**

Model No.	Dimensions						
	A	B	C	D	E	F	G
<b>DNS-1319</b>	39.8	20.9	7.0	19.0	49.7	29.0	120.0
<b>DNS-1924</b>	53.8	25.3	10.0	25.0	62.2	40.0	146.0
<b>DNS-2432</b>	64.0	33.6	13.0	30.0	76.5	51.8	181.0
<b>DNS-3241</b>	77.0	42.7	16.0	36.0	87.3	64.9	205.0
<b>DNS-4150</b>	94.0	53.8	21.1	44.7	108.0	76.0	244.0
<b>DNS-5060</b>	106.0	60.8	24.3	54.3	125.3	92.0	289.0
<b>DNS-6075</b>	156.2	80.4	27.0	75.0	184.0	110.0	365.0

- 4.2 Make hydraulic connections; use a pump release valve or a 3-way valve and one hose for single-acting cylinder.
- 4.3 Check all system fittings and connections to be sure they are tight and leak free.
- 4.4 Check oil level in reservoir before operating pump.

## 5.0 Operation



### WARNING:

- Maximum Nut Hardness is HRC-44 - these Hydraulic Nut Splitters **ARE NOT** suitable for stainless steel nuts or square nuts. They are suitable for use on Grade 2H high temperature nuts as used in the Petro-chemical industry
- Splitting nuts with a worn or damaged chisel may cause property damage or even personal injury



### IMPORTANT:

- It is mandatory that the operator has a full understanding of all instructions, safety regulations, cautions and warnings, before starting to operate any of this high force tool equipment
  - To reduce the risk of personal injury and/or property damage, hydraulic connections must be securely fastened before building pressure in the system. Release all system pressure before loosening any hydraulic connection in the system
  - Always monitor pressure, load or position using suitable equipment. Pressure may be monitored by means of an optional manifold and gauge. Correct application position can only be determined by the operator of the equipment
  - Never operate a pump that is not connected to an application. If operated in this condition, the hose and connections will become pressurised. This increases the chance of a burst hazard. Damage may also occur to the pump and its components
  - **Do NOT** cut chains or bolts
  - **Do NOT** use the nut splitter to rotate nuts
  - **Do NOT** move the tool during operation
  - **Do NOT** heat up nuts with the nut splitter in position
  - **Do NOT** use your fingers when looking for fluid leaks
  - Never adjust the pump relief valve over 700 bar
  - Suggested working temperatures: -10°C ~ 40°C. Check hydraulic fluid specifications
- 5.1 Connect the pump hose and splitter couplers. Firmly tighten the couplers to prevent restricted oil flow between the pump and the hydraulic tool head.
  - 5.2 To remove air trapped in the hydraulic system, position the nut splitter so that the piston is pointed down and the nut splitter is lower than the pump. Operate the pump to advance and retract the chisel several times, avoiding pressure build-up. Air removal is complete when the nut splitter motion is smooth.
  - 5.3 Retract the piston and the chisel. The product is now ready to operate.

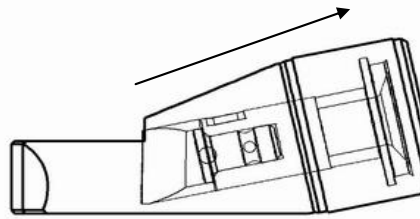

Figure 3 – Nut Splitter Operation

- 5.4 Position the splitter on the nut. Make sure the nut is squared nicely at the top of the splitter tool head. Improper positioning of the splitter on the nut might cause damages to the chisel.

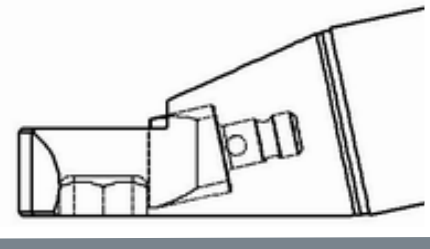
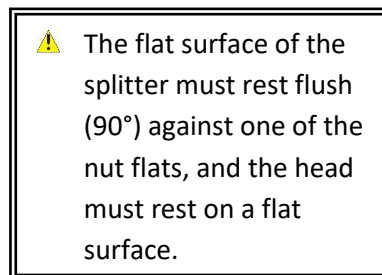

Figure 4 – Surface Operation

- 5.5 Hold the splitter in place and operate the pump until the chisel cuts through the nut. Stop the pump immediately after the nut is split to avoid damages to the bolt threads.
- 5.6 Retract the chisel and lift the splitter off the nut.
- 5.7 If the nut cannot be removed after one cut, reposition the splitter on the side opposite (180°) to the first split and repeat the operation.
- 5.8 Turn off the pump after the nut is split and the chisel is retracted completely.
- 5.9 Dismount the couplers and the hose and replace the dust caps to all couplers. If the couplers cannot be dismantled, release the internal pressure from the pump.

## 6.0 Maintenance



### IMPORTANT:

- Use only good quality hydraulic fluid. **Do NOT** use brake fluid, transmission fluid, turbine oil, motor oil, alcohol, glycerine etc. Use of anything other than good quality hydraulic oil will void warranty and damage the pump, hose, and application. We recommend Durapac Hydraulic Oil or equivalent
- Routine renewal of pump oil is required. Particles mixed in the pump oil is the most common cause of product failure
- Use a lubricant to clean the tool when necessary
- Routine application of rust preventive oil to the product is needed. Avoid bringing the tool into contact with water or solvents
- Equipment must only be serviced by a qualified hydraulic technician. For repair service,

contact your local Durapac authorised service centre

- Inspect hoses and connections daily. Replace damaged components immediately
- Tighten connections as needed. Use non-hardening pipe thread compound when servicing connections
- Release pressure from the system before servicing
- Keep the tool head free of dirt and metal chips

Dirt, sand, etc. will quickly ruin any hydraulic system. Ensure that couplings are clean and free of foreign matter. After each use, clean couplings and attach dust caps.

Maintenance is required when wear or leakage is noticed. Periodically inspect all components to detect any problem that may require service and maintenance.

Refer to the Parts Specification Table below for the wrench and screw specifications for all models of splitters.

**Table 3 – Parts Specifications**

Model No.	Parts		
	Screw (#2)	Screw (#6)	Hex Wrench (mm)
<b>DNS-1319</b>	M8×1.25×10	M5×0.8×4	2.5 & 4
<b>DNS-1924</b>	M10×1.5×8	M6×1×6	3 & 5
<b>DNS-2432</b>	M12×1.75×10	M8×1.25×6	4 & 6
<b>DNS-3241</b>	M12×1.75×10	M8×1.25×6	4 & 6
<b>DNS-4150</b>	M12×1.75×10	M8×1.25×6	4 & 6
<b>DNS-5060</b>	M14×2×18	M10×1.5×12	5 & 6
<b>DNS-6075</b>	M14×2×18	M10×1.5×12	5 & 6

### 6.1 Chisel Replacement - Removal

**⚠** Proper wrenches, with the correct specifications are required for replacing chisels, or the product may be damaged.

- 6.1.1 Remove the setscrew (#2<sup>1</sup>) from the side of the Main Body (#1<sup>1</sup>).

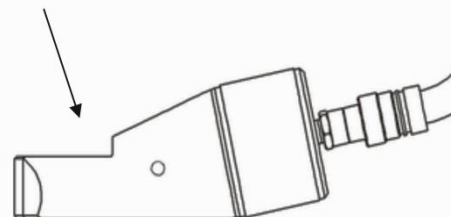

Figure 5 – Setscrew removal

- 6.1.2 Operate the pump to advance the chisel until it is fully extended.

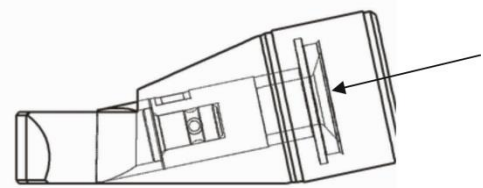

Figure 6 – Accessing the chisel

<sup>1</sup> Refer to the Parts Breakdown in Section 8 to see the corresponding numbered part.



6.1.3 Remove the smaller setscrew (#6<sup>1</sup>) from the same hole in the side of the Main Body (#1<sup>1</sup>).

6.1.4 Retract the piston to separate the chisel from the piston. Pull the chisel out of the Main Body.

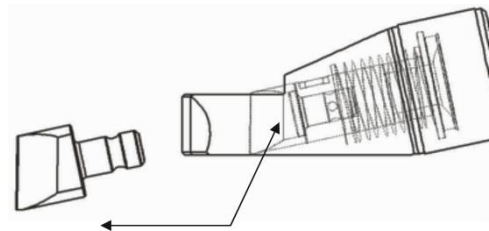

Figure 7 – Chisel removal

## 6.2 Chisel Replacement - Installation

6.2.1 Advance the cylinder piston until fully extended.

6.2.2 Place the chisel in the cylinder and align it to the correct position. Insert the small setscrew (#6<sup>1</sup>) and tighten. The setscrew must be tightened firmly, or the chisel may perform improperly.

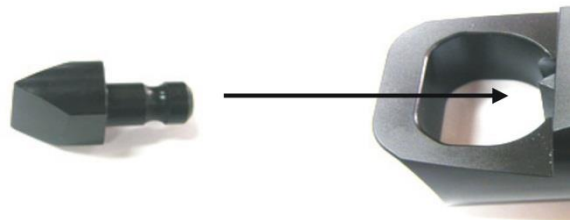

Figure 8 – Positioning chisel

6.2.3 Retract the piston and the chisel. Insert the larger setscrew (#2<sup>1</sup>) and tighten.



Figure 9 – Retract piston & chisel

6.2.4 Check the splitter and cylinder action by advancing and retracting the chisel several times.

- ⚠ If the piston cannot be retracted after the chisel is replaced:
- The setscrew #6<sup>1</sup> might not be tightened firmly enough, or the replaced chisel is misaligned with the piston, interfering with the motion of the piston. Remove the setscrews and repeat steps to reinstall the chisel
  - A squeal of metal while advancing or retracting the piston indicates that the setscrew #2<sup>1</sup> may be over-tightened and interfering with the motion of the piston. Adjust setscrew #2 so the piston will not be scratched

**7.0 Troubleshooting**

<b>Problem</b>	<b>Cause</b>	<b>Solution</b>
<b>Failure to split nuts</b>	Worn or damaged chisel	<ul style="list-style-type: none"> <li>• Contact a Durapac authorised service centre</li> <li>• Repair or replace as necessary</li> </ul>
	The hardness or size of applied nuts might exceed equipment ratings	<ul style="list-style-type: none"> <li>• Contact a Durapac authorised service centre</li> <li>• Repair or replace as necessary</li> </ul>
	Insufficient pump output	<ul style="list-style-type: none"> <li>• Contact a Durapac authorised service centre</li> <li>• Repair or replace as necessary</li> </ul>
	Internal leakages of hydraulic fluid	<ul style="list-style-type: none"> <li>• Contact a Durapac authorised service centre</li> <li>• Repair or replace as necessary</li> </ul>
<b>Insufficient operating pressure</b>	Operating pressure is less than 700 bar (10,000 psi)	<ul style="list-style-type: none"> <li>• Secure the couplers properly to prevent restricted oil flow</li> <li>• Inspect the pump output for possible pressure losses</li> <li>• Test the pump to ensure it reaches 700 bar pressure</li> </ul>
<b>Piston cannot be retracted after the chisel is replaced</b>	The setscrew #6 <sup>1</sup> might not be tightened firmly enough, or the replaced chisel is misaligned with the piston, interfering with the motion of the piston	<ul style="list-style-type: none"> <li>• Remove the setscrews and follow the Chisel Replacement steps outlined in the Operation Section</li> </ul>
	A squeal of metal while advancing or retracting the piston indicates that the setscrew #2 <sup>1</sup> may be over-tightened and interfering with the motion of the piston	<ul style="list-style-type: none"> <li>• Adjust setscrew #2<sup>1</sup> so the piston will not be scratched</li> </ul>

 Contact your Durapac Service Centre to request parts or to address any problems not shown above.

**8.0 Parts Breakdown and List**

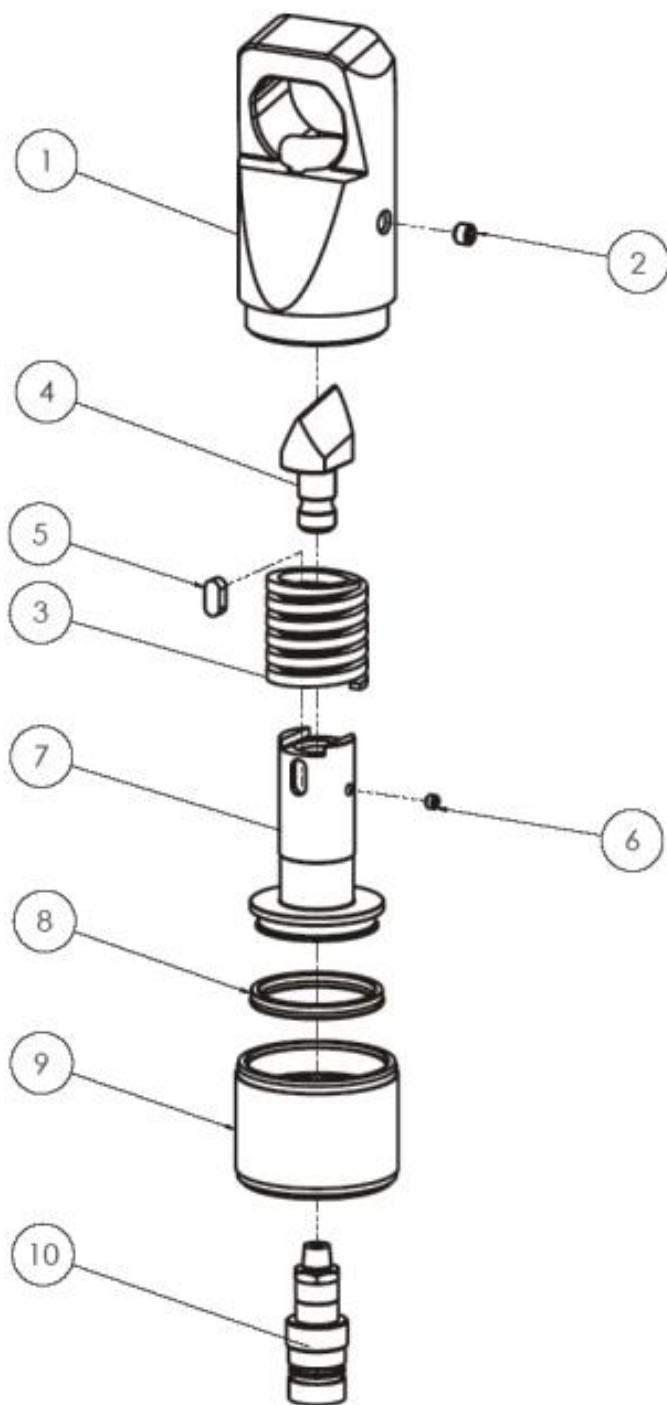

Item	Description	Qty
1	Main Body	1
2	Screw	1
3	Spring	1
4	Moving Blade	1
5	Guide Piece	1
6	Screw	1
7	Piston	1
8	O-Ring	1
9	Cylinder	1
10	Coupler	1

Note – Not all components of the Nut Splitter are replacement items, but are illustrated as a convenient reference of location and position in the assembly sequence.