

DURAPAC
ENGINEERED FOR RELIABILITY

Instruction Manual

10 Ton Deluxe Collision Repair Kit
Model – CRK-10D



Maximum Operating Pressure – 700 bar



This is a safety alert symbol. It is used to alert you to potential personal injury hazards. Obey all safety messages that follow this symbol to avoid injury or death

1.0 Product Information

DURAPAC – Collision Repair Kits are engineered to meet Industrial Standards for Performance and Safety. The maintenance and repair kits are an indispensable hydraulically powered tool set. They can be used for pressing, spreading, lifting, straightening and clamping in workshops and collision repair centres. Most components are threaded for durability and the extension tubes feature a heavy wall for increased resistance to bending and deformation. Industry standard high flow hydraulic couplings and dust caps are supplied with all kits.

Special skill, knowledge and training may be required for a specific task and the product may not be suitable for all jobs. The user must ultimately make the decision regarding suitability of the product for any given task and assume the responsibility of safety for all in the work area. Contact a Durapac representative if you are unsure of your repair kit's suitability for a particular application.

2.0 Receiving Instructions

It is recommended prior to use that an inspection be done by qualified personnel and that any missing or damaged parts, decals, warning/safety labels or signs are replaced with Durapac authorised replacement parts only. Any repair kit or component that appears to be damaged in any way, is worn, leaking or operates abnormally should be removed from service immediately until such time as repairs can be made. Any repair kit or component that has been or suspected to have been subject to a shock load should be removed from service immediately until inspected by a Durapac authorised service centre. Owners and operators of this equipment should be aware that the use and subsequent repair of this equipment may require specialised training and knowledge.

3.0 Safety

Save these instructions. For your safety, read and understand the information contained within. The owner and operator should have an understanding of this product and safe operating procedures before attempting to use this product. Instructions and safety information should be conveyed in the operator's native language before use of this product is authorised. Make certain that the operator thoroughly understands the inherent dangers associated with the use and misuse of the product. If any doubt exists as to the safe and proper use of this product as outlined in this factory authorised manual, remove from service immediately.



DANGER:

- To avoid personal injury keep hands and feet away from work area during operation
- **Do NOT** handle pressurised hoses. Escaping oil under pressure can penetrate the skin causing serious injury. If oil is injected under the skin, see a doctor immediately
- Stay clear of loads supported by hydraulics. A cylinder, when used as a load lifting device, should never be used as a load holding device. After the load has been raised or lowered, it must always be supported mechanically

**WARNING:**

- The system operating pressure must not exceed the pressure rating of the lowest rated component in the system. Install pressure gauges in the system to monitor operating pressure. It is your window to what is happening in the system
- Always wear appropriate personal protective equipment (PPE) when operating hydraulic equipment. The operator must take precaution against injury due to failure of the tool or work piece(s)
- **Do NOT** hold or stand directly in line with any hydraulic connections while pressurising
- **Do NOT** attempt to disconnect hydraulic connections under pressure. Release all line pressure before disconnecting hoses
- All personnel must be clear before lowering load or depressurising the system
- **Do NOT** attempt to lift a load weighing more than the capacity of the cylinder

**IMPORTANT:**

- If at any stage, the safety related decals become hard to read, these must be replaced
- Minimum age of the operator must be 18 years. The operator must have read and understood all instructions, safety issues, cautions and warnings before starting to operate the equipment. The operator is responsible for this activity towards other persons
- **Do NOT** lift hydraulic equipment by the hoses or couplers. Use the carrying handle or other means of safe transport
- Hydraulic equipment must only be serviced by a qualified hydraulic technician. For repair service, contact the Durapac authorised service centre in your area. To protect your warranty, use only high quality hydraulic oil

**CAUTION:**

- **KEEP HYDRAULIC EQUIPMENT AWAY FROM FLAMES AND HEAT.** Hydraulic fluid can ignite and burn. Excessive heat will soften packings and seals, resulting in fluid leaks. Heat also weakens hose materials and packings. For optimum performance do not expose equipment to temperatures of 65°C (150°F) or higher. Protect all equipment from weld spatter
- No alteration should be made to this device

3.1 Hydraulic Pumps

- **Do** use a gauge or other load measuring instrument to verify load
- **Do NOT** exceed the rated capacity of the pump or any equipment in the system. Burst hazard exists if connection pressure exceeds rated pressure
- **Do NOT** operate the system with bent or damaged couplers or damaged threads
- **Do NOT** subject the pump and its components to shock loads
- Use only Durapac approved accessories and components
- **Do NOT** connect to an application which can return more oil to the reservoir than the

pump reservoir can hold

- **Do NOT** connect pump to a hydraulic system that is powered by another pump

3.2 Hydraulic Cylinders / Spreaders

- If bowing or bending of the spreader jaws occurs, STOP. Immediately release pressure! Evaluate the set-up and consider a higher capacity system. Bowing or bending of components indicates that the spreader is overloaded
- **USE ONLY RIGID PIECES TO HOLD LOAD.** Carefully select steel or wood blocks that are capable of supporting the load. Never use a hydraulic cylinder as a shim or spacer in any lifting or pressing application
- **BE SURE SETUP IS STABLE BEFORE LIFTING LOAD.** Cylinders should be placed on a flat surface that can support the load. Where applicable, use a cylinder base for added stability. Do not weld or otherwise modify the cylinder to attach a base or other support
- Avoid situations where loads are not directly centred on the cylinder piston. Off-centre loads produce considerable strain on cylinder and pistons. In addition, the load may slip or fall, causing potentially dangerous results
- Distribute the load evenly across the entire saddle surface. **Always** use a saddle to protect the piston (if one is provided)
- Ensure that both spreader jaws fully engage the load and that the load is centred on the serrated portion of each spreader jaw before pressurising the spreader. Do not load off-centre
- **Never** pressurise uncoupled couplers. Only use hydraulic equipment in a coupled system
- Cylinders and spreaders should be stored where protected from the elements, abrasive dust, and damage. These devices may be stored in virtually any position

3.3 Hydraulic Hoses & Fluid Transmission Lines

- Avoid short runs of straight line tubing. Straight line runs do not provide for expansion and contraction due to pressure and/or temperature changes
- Reduce stress in tube lines. Long tubing runs should be supported by brackets or clips. Before operating the pump, connections should be tightened securely and leak-free. Over tightening can cause premature thread failure or high pressure fittings to burst
- Should a hydraulic hose ever rupture, burst or need to be disconnected, immediately shut off the pump and release all pressure. Never attempt to grasp a leaking pressurised hose with your hands. The force of escaping hydraulic fluid can inflict injury
- **Do NOT** subject the hose to potential hazard such as fire, sharp objects, extreme heat or cold or heavy impact
- **Do NOT** allow the hose to kink, twist, curl, crush, cut or bend so tightly that the fluid flow within the hose is blocked or reduced. Periodically inspect the hose for wear

- Hose material and coupler seals must be compatible with the hydraulic fluid used. Hoses also must not come in contact with corrosive materials such as battery acid, creosote-impregnated objects and wet paint. Never paint a coupler or hose

3.4 Attachments

- Attachments and extension tubes must be aligned and fully engaged so cylinder force is straight, avoiding an off-centre load condition
- When offset attachments are used, the rated capacity of the hydraulic system is reduced 50% (5 ton). For each extension tube used in the setup, the rated capacity is reduced another 50% (2.5 ton, 1.2 ton~). When using two or more extension tubes together, always position the shortest tube furthest away from the cylinder

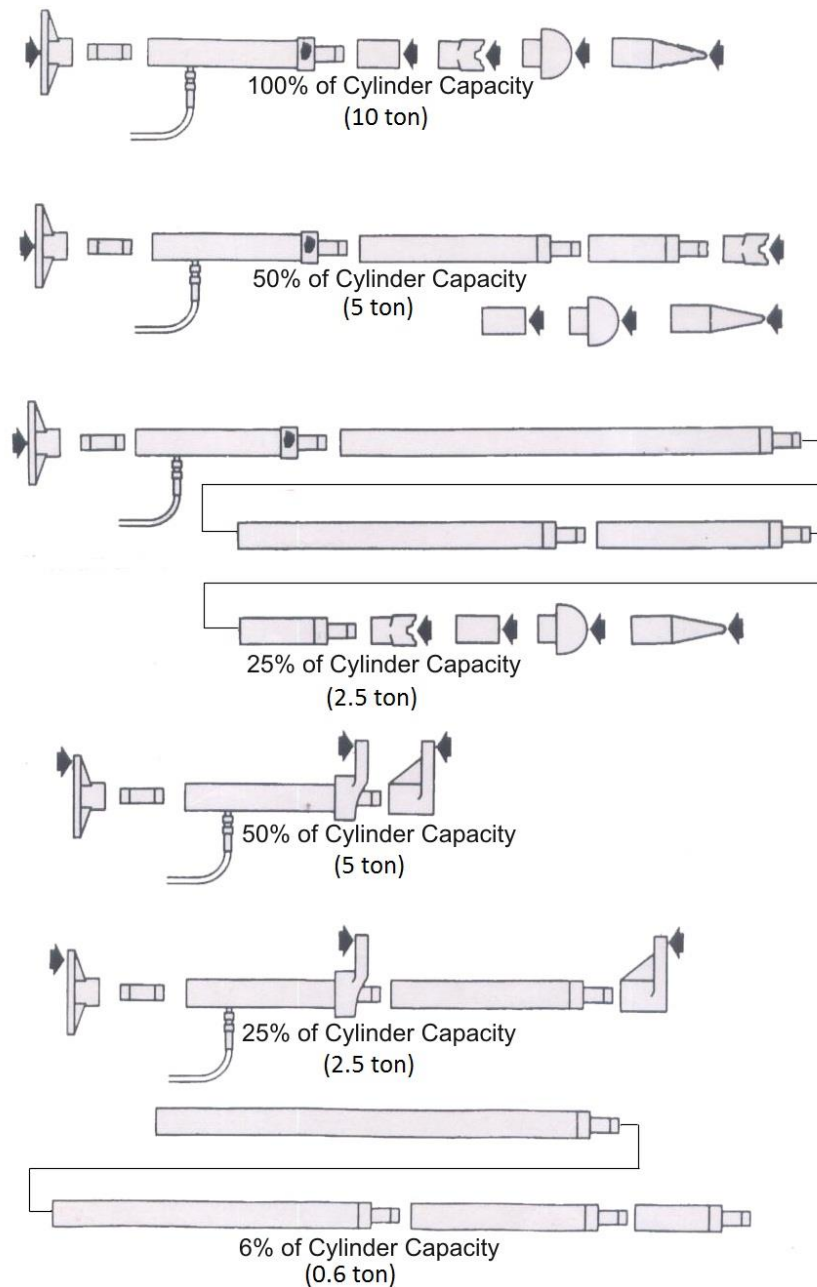



Figure 1 – Illustration of Application and Load Capacities

FAILURE TO HEED THESE WARNINGS MAY RESULT IN PERSONAL INJURY AS WELL AS PROPERTY DAMAGE.

4.0 Installation

 **IMPORTANT:** Always secure threaded port connections with high grade, non-hardening pipe thread sealant. Teflon tape can be used if only one layer of tape is used and it is applied carefully, two threads back, to prevent the tape from being introduced into hydraulic system, which could cause jamming of precision-fit parts

 **CAUTION:** DO NOT allow the piston rod to rotate when installing adaptors. Damage to the spring may prevent piston rod retraction

4.1 Familiarise yourself with the specifications and illustrations in this owner’s manual. Know your product, its limitations and how it operates before attempting to use. Refer to the specification chart below or if in doubt, contact a Durapac representative.

	Capacity (ton)	Stroke (mm)	Max Pressure (bar)	Pressure Rating (bar)		Usable Oil Capacity (cc)	Oil Volume per Stroke (cc)		Oil Port Thread	Weight (kg)
				1st Stage	2nd Stage		1st Stage	2nd Stage		
Pump	-	-	700	13.8	700	600	13	2.8	3/8" NPTF	7.2
Cylinder*	10	150	700	-	-	-	-	-	3/8" NPTF	5.3
Pull Cylinder	5	154	700	-	-	-	-	-	3/8" NPTF	5.0
Spreader	0.5	77	700	-	-	-	-	-	3/8" NPTF	1.9

* When attachments are used, the rated capacity of the hydraulic system can be reduced (refer to Section 3.4 for details)

4.2 Make hydraulic connections – Remove the manifold plug and then connect oil output port to suitable fittings and application/cylinder.

 **IMPORTANT:** Fully hand-tighten all couplers. Loose coupler connections will block the flow of oil between the pump and the cylinder/spreader

4.3 Remove air from the system – Air can accumulate in the hydraulic system during the initial setup or after prolonged use, causing the cylinder and/or spreader to respond slowly or in an unstable manner. Should removal of air be required, please follow the steps in 6.2 - Bleeding Air from the System.

5.0 Operation



IMPORTANT:

- **Do NOT** add extensions to the pump handle. Extensions cause unstable pump operation
- In certain situations the pump handle can "kick back". Always keep your body to the side of the pump, away from the line of force of the handle
- **Do NOT** operate a pump that is disconnected from the application. If operated in this condition, the hose and connections will become pressurised. This increases burst hazard. Damage may occur to pump and its components

The pump may be operated in a horizontal or in a vertical position with the head pointing down as shown.

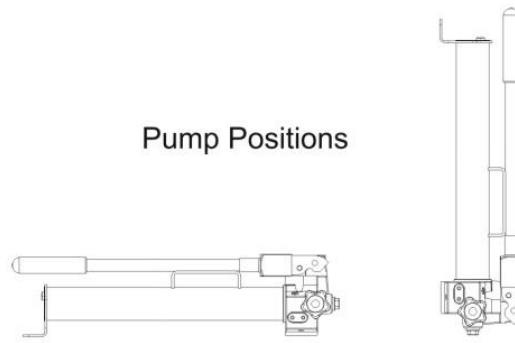

Figure 2 – Hand Pump Operation

5.1 Before Using the Pump

- 5.1.1 Check all system fittings and connections to be sure they are tight and leak free.
- 5.1.2 Check oil level in reservoir before operating pump.

5.2 Using a Two-Speed Pump

This pump provides 2-stage flow. Under no-load, the pump operates in the high flow first stage for rapid advance. When the load is contacted, the pump automatically shifts to the second stage for building pressure. After the pump shifts, pumping takes less effort.

Note: To reduce handle effort at high pressure, take short strokes. Maximum leverage is obtained in the last 5° of stroke. For best performance, operate pump handle at moderate speed during the high flow first stage. Rapid handle speed in the first stage will prevent the pump from delivering full volume of oil.

5.3 Advance and Retraction of Single-Acting Applications

- 5.3.1 Turn the pump's release valve clockwise to a closed position.
⚠ IMPORTANT: Only hand-tighten the valve. Applying too much force to the valve may damage the valve stem

- 5.3.2 Work the pump handle up and down to send oil through the hose to the cylinder, causing the piston to extend to the work piece.

- 5.3.3 Monitor the pressure gauge while completing the application.

Note: The pump is equipped with an overload valve that will bypass oil back into the pump reservoir in an overload situation (when the system meets maximum pressure). In this case, continued pumping will have no effect on the system. If an overload situation commonly occurs, a higher capacity set is needed.

- 5.3.4 To release pressure, slowly turn the release valve counter clockwise. The release speed is controlled by how fast the valve is opened.

5.4 Relief Valve Adjustment

All pumps contain a factory set relief valve to prevent over-pressurisation of the system.

6.0 Maintenance



IMPORTANT:

- Check oil level regularly
- Use only good quality hydraulic fluid. **Do NOT** use brake fluid, transmission fluid, turbine oil, motor oil, alcohol, glycerine etc. Use of anything other than good quality hydraulic oil will void warranty and damage the pump, hose, and application. We recommend Durapac Hydraulic Oil or equivalent
- Equipment must only be serviced by a qualified hydraulic technician. For repair service, contact your local Durapac authorised service centre
- Damage to hydraulic hoses may not be detected during visual inspections. For this reason, Durapac recommends that hydraulic hoses be replaced on a regular basis
- Tighten connections as needed. Use non-hardening pipe thread compound when servicing connections

Dirt, sand, etc. will quickly ruin any hydraulic system. Ensure that couplings are clean and free of foreign matter. After each use, clean couplings and attach dust caps.

Maintenance is required when wear or leakage is noticed. Periodically inspect all components to detect any problem that may require service and maintenance.

6.1 Adding Hydraulic Fluid

⚠ WARNING: Always add oil with cylinders fully retracted (or extended, if pull cylinders) or the system will contain more oil than the reservoir can hold

- 6.1.1 Depressurise and disconnect hydraulic hose from application/cylinder.
- 6.1.2 Put the pump in a vertical position (pump head face down), remove oil filler plug located on rear of the pump reservoir.
- 6.1.3 Use a small funnel to fill the reservoir to approximately 75 mm from the top of the oil filler hole.
- 6.1.4 Bleed air from system if necessary.
- 6.1.5 Wipe up any spilled fluid and reinstall the air vent plug/reservoir cap.

6.2 Bleeding Air from the System

- 6.2.1 Repeat Steps 6.1.1 to 6.1.3 (above), if required.
- 6.2.2 Invert cylinder and place at a lower level than the pump reservoir.
- 6.2.3 Extend and retract the cylinder several times without putting a load on the system. Air will be released into the pump reservoir.
- 6.2.4 Recheck oil level after removing air.

6.3 Changing Hydraulic Fluid

⚠ For best results, change fluid once a year or every 300 hours of use

- 6.3.1 Repeat Steps 6.1.1 to 6.1.2 (above).
- 6.3.2 Pour used fluid into a sealable container.
- 6.3.3 Repeat Steps 6.1.3 to 6.1.5 (above).
- 6.3.4 Dispose of fluid in accordance with local regulations.

6.4 Lubrication

To extend pump life and improve performance, lubricate the beam pin (A), cross pin (B), and piston head (C) regularly, using roller bearing grease.

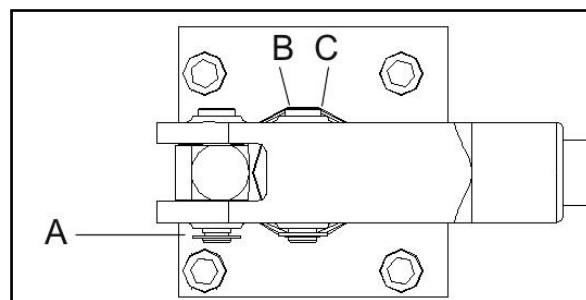

Figure 3 - Lubrication

6.5 Storage

- 6.5.1 When not in use, depressurise and disconnect the hydraulic pump from the application.
- 6.5.2 Wipe clean thoroughly and store in a clean, dry environment. Avoid temperature extremes.
- 6.5.3 Shield pump with a protective cover.

7.0 Troubleshooting

Problem	Cause	Solution
Pump loses pressure	Leaking system components	<ul style="list-style-type: none"> • Repair or replace as necessary
Pump not delivering fluid	Low fluid level in reservoir	<ul style="list-style-type: none"> • Check fluid level
	Worn seats	<ul style="list-style-type: none"> • Repair seats • Replace pump body
Pump does not reach rated capacity	Low fluid level in reservoir	<ul style="list-style-type: none"> • Check fluid level
	Leaking system components	<ul style="list-style-type: none"> • Repair or replace as necessary
	Fluid leaking past inlet or outlet checks	<ul style="list-style-type: none"> • Repair inlet or outlet checks • Replace high pressure piston seal
Pump handle has a “spongy” feel	Air trapped in system	<ul style="list-style-type: none"> • Refer to 6.2 - Bleeding Air from the System
	Too much fluid in reservoir	<ul style="list-style-type: none"> • Check fluid level
Cylinder piston will not extend	Loose couplers	<ul style="list-style-type: none"> • Tighten couplers
	Low fluid level in pump reservoir	<ul style="list-style-type: none"> • Fill and bleed the system
	Leaking cylinder seals	<ul style="list-style-type: none"> • Replace worn seals. Look for excessive contamination or wear
Cylinder piston extends only partially	Low fluid level in pump reservoir	<ul style="list-style-type: none"> • Fill and bleed the system
	Load above capacity of system	<ul style="list-style-type: none"> • Use correct equipment
Cylinder piston extends slower than normal	Loose couplers	<ul style="list-style-type: none"> • Tighten couplers
	Restricted hydraulic line or fitting	<ul style="list-style-type: none"> • Clean and replace if damaged
	Pump not operating correctly	<ul style="list-style-type: none"> • Check pump’s operating instructions • Repair or replace as necessary
	Low fluid level in pump reservoir	<ul style="list-style-type: none"> • Fill and bleed the system
Cylinder does not hold pressure	Leaky connection	<ul style="list-style-type: none"> • Clean, reseal with thread sealant, and tighten connection
	Leaking cylinder seals	<ul style="list-style-type: none"> • Replace worn seals. Look for excessive contamination or wear. Replace contaminated fluid
	Pump or valve not operating correctly	<ul style="list-style-type: none"> • Repair or replace as necessary
Cylinder will not retract or retracts slower than normal	Closed pump release valve	<ul style="list-style-type: none"> • Open pump release valve
	Loose couplers	<ul style="list-style-type: none"> • Tighten couplers
	Blocked hydraulic lines	<ul style="list-style-type: none"> • Clean and flush lines
	Weak or broken retraction springs	<ul style="list-style-type: none"> • Send to a Durapac authorised service centre for repair
	Internally damaged cylinder	<ul style="list-style-type: none"> • Send to a Durapac authorised service centre for repair
	Pump reservoir too full	<ul style="list-style-type: none"> • Drain fluid to correct level

8.0 Parts Breakdown and List

Image	Description	Part No.	Qty
	2 Speed 700 Bar Pump with 1.5mtr Hose & Coupler	P-260 with Hose & Coupler	1
	10 Ton Cylinder - 150mm Stroke	RC-106T	1
	1/2 Ton Spreader	DHS-05	1
	5 ton 154mm Pull Cylinder	RP-56	1
	Gauge Adapter	FGA-1	1
	Liquid Filled Force Gauge	ZAL1403	1
	Adj. Body Spoon	ZAL1002	1
	3-1/4" Rubber Flex Head	ZAL1003	1
	Pull Ring	ZAL1040	2
	Pull Clamp	ZAL1063	2
	Box Clamp	ZAL1064	2
	Male Connector	ZAL1074	2
	Female Connector	ZAL1075	2
	Extension Tubes (127, 254, 508, 635 mm)	ZAL1076, ZAL1077, ZAL1078, ZAL1079	1 (of each)
	Lock Pin	ZAL1101	2

Continues next page >>

Image	Description	Part No.	Qty
	Piston Rod Toe	ZAL1177	1
	Spreader Toe	ZAL1178	1
	90° V Base	ZAL1179	1
	Wedge Head	ZAL1180	1
	Flat Base	ZAL1181	1
	Serrated Saddle	ZAL1182	1
	Offset Pull Toe	ZAL1183	2
	Clamp End Toe	ZAL1184	1
	Collar Toe	ZAL1186	1
	Clamp Head	ZAL1189	1
	Chain Pull Plate	ZAL1190	1
	3/8" x 5' Chain & Hook	ZAL1386	2
	3- Shelf Service Cart	ZAL1009	1

8.1 Pump Assembly – Model P-260

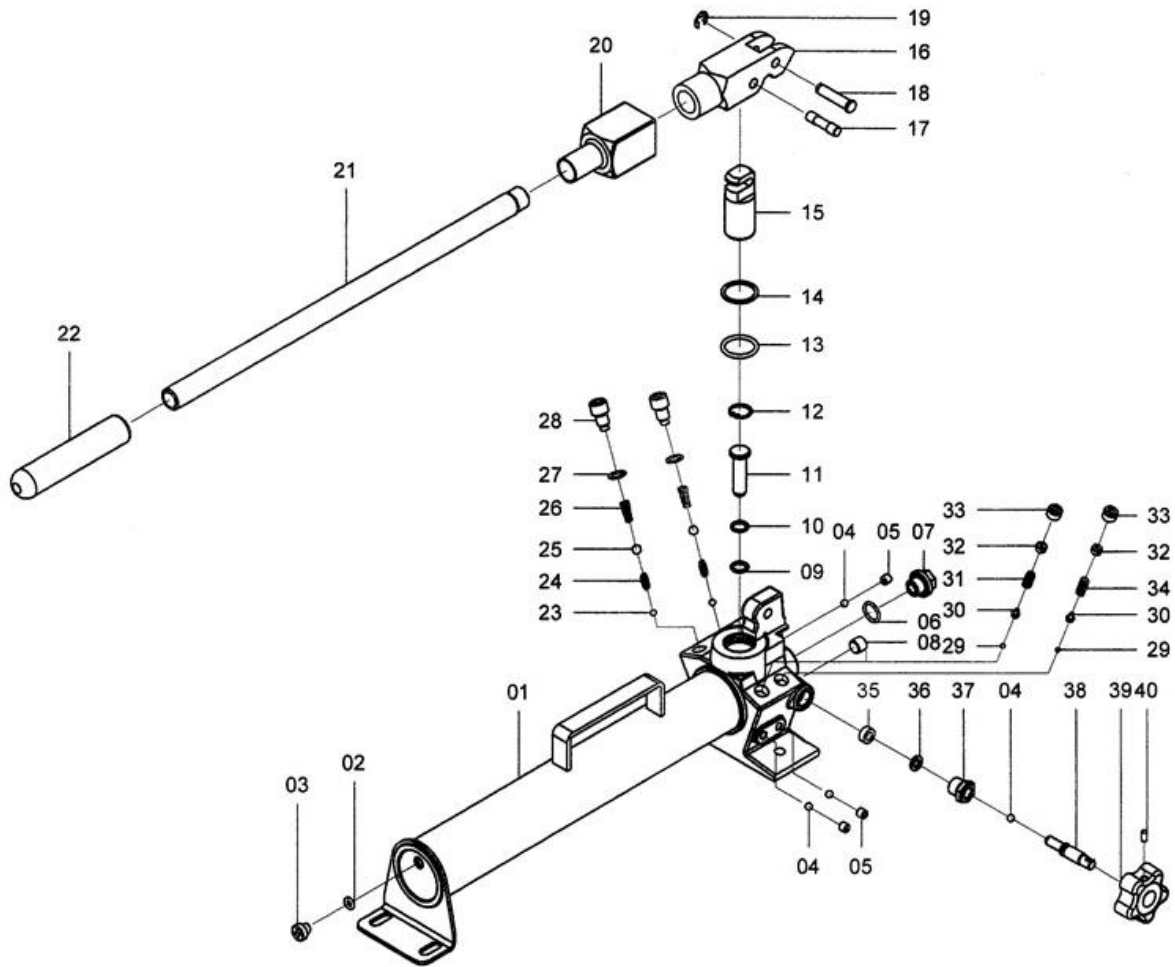

Item	Description	Part No.	Qty	Item	Description	Part No.	Qty	Item	Description	Part No.	Qty
1	Pump housing	ZAL1010	1	15	L.P. piston	ZAL1103	1	28	Valve cover screw	ZAL1286	2
2	O-ring*	ZAL1210	1	16	Yoke	ZAL1176	1	29	Steel ball	ZAL1370	2
3	Air release screw	ZAL1285	1	17	Piston pin	ZAL1108	1	30	Spring end cap	ZAL1096	2
4	Steel ball	ZAL1366	4	18	Yoke pin	ZAL1095	1	31	L.P. spring	ZAL1350	1
5	Screw	ZAL1284	3	19	Retaining ring	ZAL1327	1	32	Screw	ZAL1175	2
6	O-ring	ZAL1229	1	20	Yoke cover	ZAL1226	1	33	Set screw	ZAL1294	2
7	Plastic plug	ZAL1264	1	21	Handle	ZAL1066	1	34	H.P. spring	ZAL1346	1
8	Set screw	ZAL1297	1	22	Handle grip	ZAL1263	1	35	Oil seal	ZAL1224	1
9	O-ring*	ZAL1272	1	23	Steel ball	ZAL1367	2	36	Washer	ZAL1351	1
10	Back-up ring*	ZAL1209	1	24	Spring	ZAL1344	2	37	Release nut	ZAL1291	1
11	H.P. piston	ZAL1406	1	25	Steel ball	ZAL1368	2	38	Release valve screw	ZAL1292	1
12	Snap ring	ZAL1329	1	26	Spring	ZAL1339	2	39	Release valve	ZAL1388	1
13	O-ring*	ZAL1277	1	27	Washer	ZAL1340	2	40	Screw	ZAL1290	1
14	Back-up ring*	ZAL1225	1						Seal kit	ZAL1396	1

8.2 Cylinder – Model RC-106T

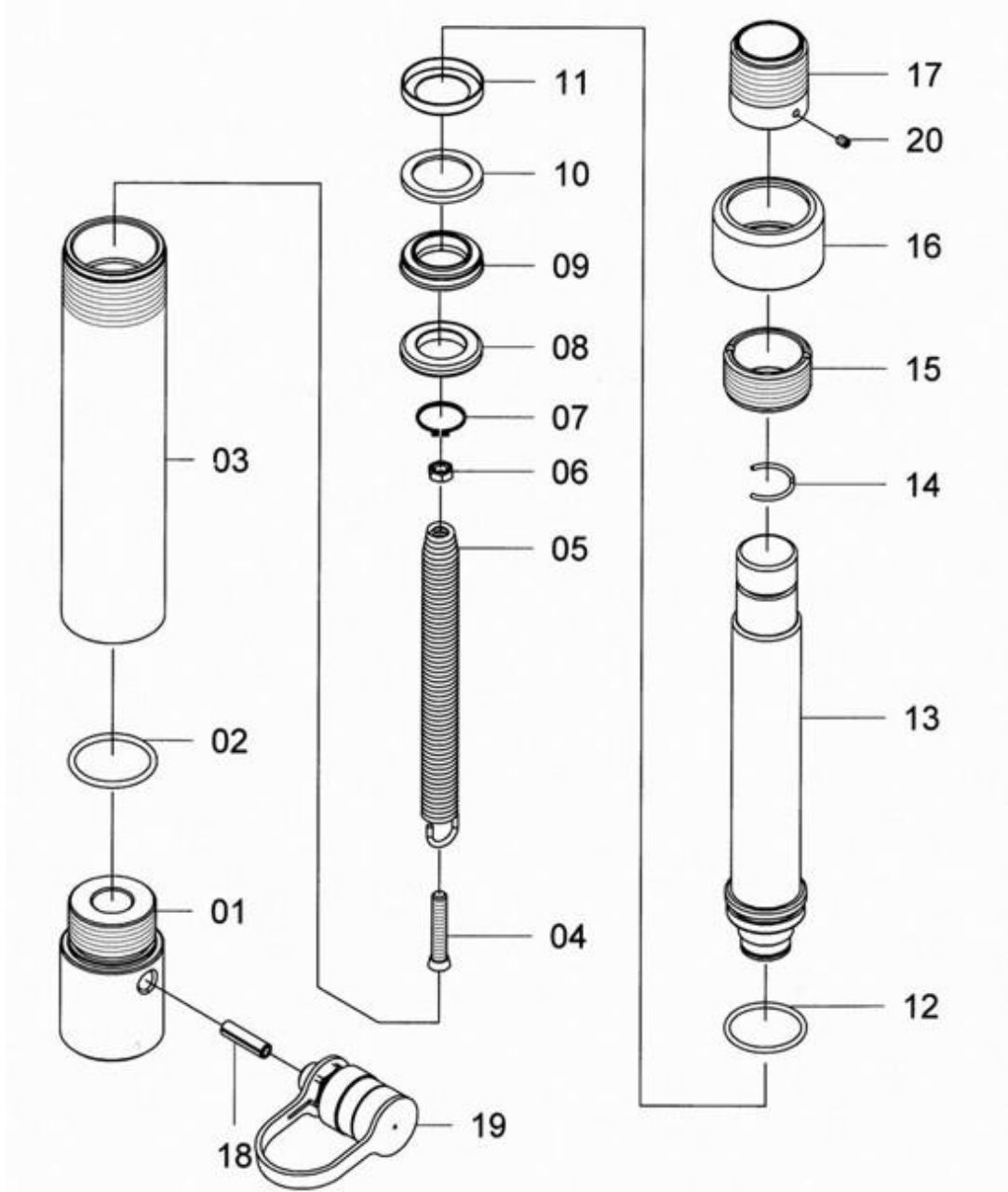

Item	Description	Part No.	Qty
1	Cylinder base	ZAL1592	1
2	O-ring*	ZAL1456	1
3	Cylinder	ZAL1457	1
4	Screw	ZAL1458	1
5	Spring	ZAL1459	1
6	Nut	ZAL1460	1
7	Snap ring	ZAL1593	1
8	Bushing	ZAL1594	1
9	U-cup seal*	ZAL1212	1
10	Back-up ring*	ZAL1213	1

Item	Description	Part No.	Qty
11	Brass bushing	ZAL1595	1
12	O-ring*	ZAL1596	1
13	Piston rod	ZAL1597	1
14	Spring ring	ZAL1467	1
15	Fasten nut	ZAL1598	1
16	Cylinder sleeve	ZAL1469	1
17	Thread adapter	ZAL1599	1
18	Pin	ZAL1471	1
19	Coupler	ZAL1472	1
20	Screw	ZAL1289	1
	Seal kit	ZAL1600	1

8.3 Puller Assembly – Model RP-56

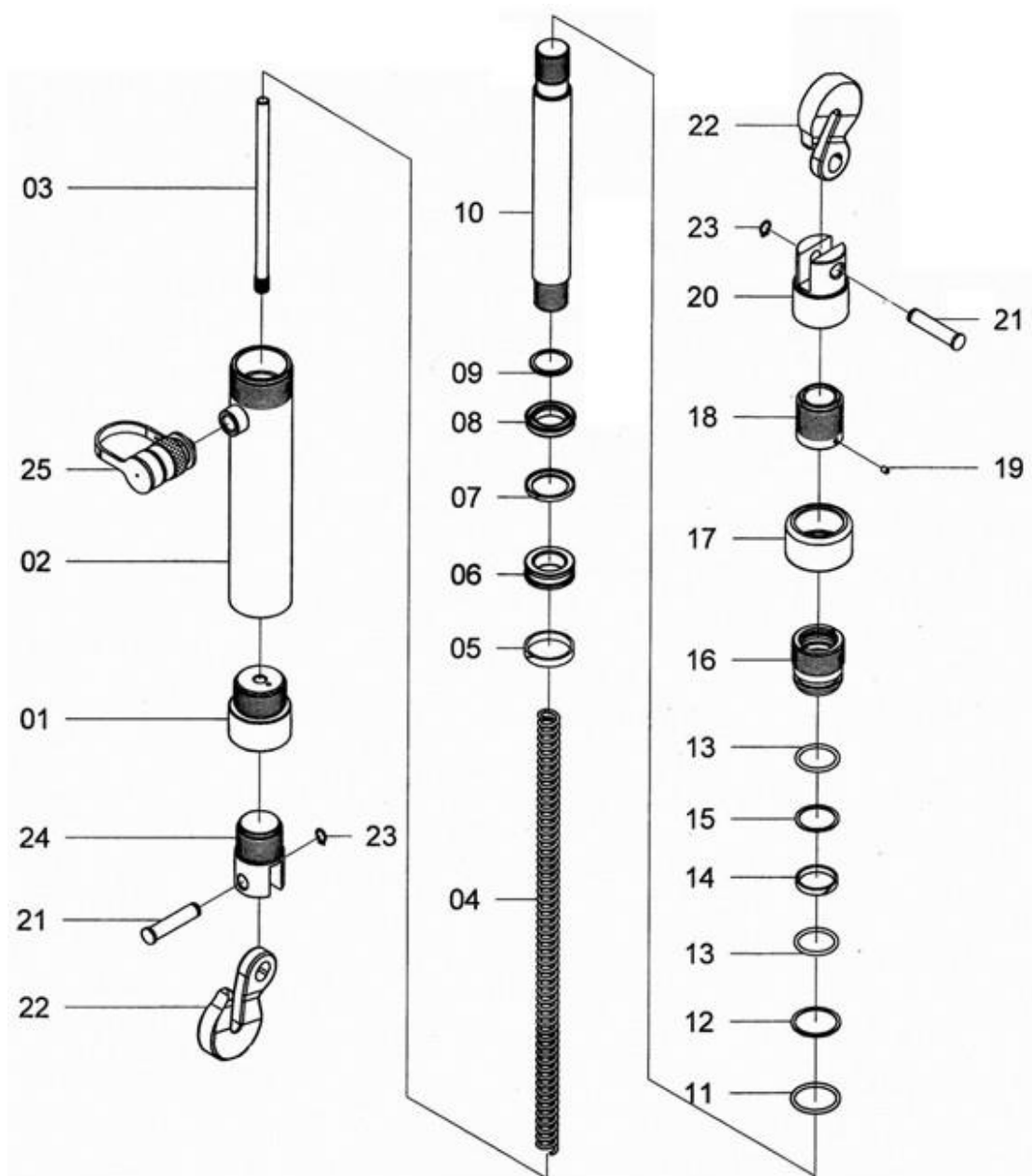

Item	Description	Part No.	Qty
1	Cylinder base	ZAL1611	1
2	Cylinder	ZAL1612	1
3	Fixing screw	ZAL1613	1
4	Spring	ZAL1614	1
5	Split ring	ZAL1615	1
6	Bypass Bushing	ZAL1616	1
7	Back-up ring*	ZAL1213	1
8	U-cup seal*	ZAL1212	1
9	Washer	ZAL1461	1
10	Piston rod	ZAL1617	1
11	O-ring*	ZAL1618	1
12	Back-up ring*	ZAL1619	1
13	O-ring*	ZAL1620	2

Item	Description	Part No.	Qty
14	Split ring	ZAL1621	1
15	Back-up ring*	ZAL1622	1
16	Fasten nut	ZAL1623	1
17	Cylinder sleeve	ZAL1469	1
18	Adapter	ZAL1624	1
19	Screw	ZAL1289	1
20	Hook connector	ZAL1625	1
21	Pin	ZAL1626	2
22	Hook	ZAL1627	2
23	Snap ring	ZAL1628	2
24	Hook connector	ZAL1629	1
25	Coupler	ZAL1472	1
	Seal kit	ZAL1630	1

8.4 DHS-05

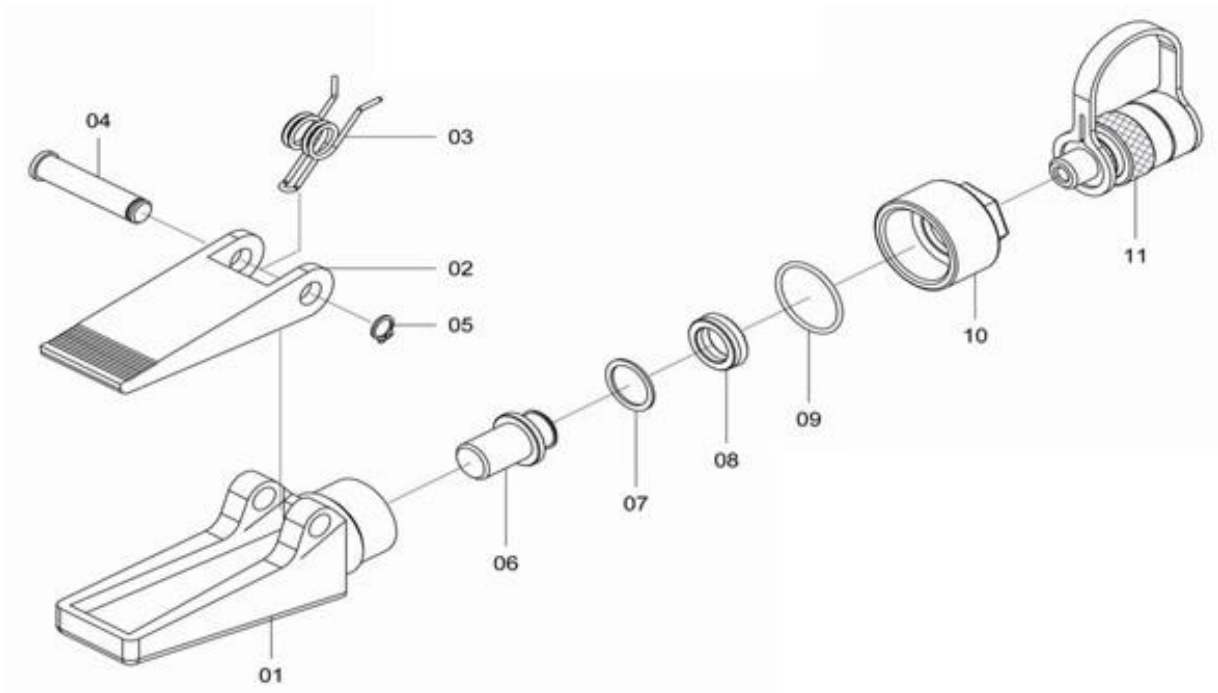

Item	Description	Part No.	Qty
1	Spreader base	ZAL1631	1
2	Spreader jaw	ZAL1632	1
3	Spring	ZAL1633	1
4	Pin	ZAL1626	1
5	Circlip	ZAL1628	1
6	Piston rod	ZAL1634	1
7	Back-up ring*	ZAL1635	1
8	Cup seal*	ZAL1636	1
9	O-ring*	ZAL1637	1
10	Cylinder	ZAL1638	1
11	Coupler	ZAL1472	1
	Seal kit	ZAL1639	1

Items marked with a * are contained within a standard seal kit.
 Serial, model and part numbers need to be quoted when ordering parts.