

DURAPAC

ENGINEERED FOR RELIABILITY

Instruction Manual

Battery Power Unit
Model – BP114A



Maximum Operating Pressure – 700 bar



This is a safety alert symbol. It is used to alert you to potential personal injury hazards. Obey all safety messages that follow this symbol to avoid injury or death

1.0 Product Information

DURAPAC – Battery Power Units are engineered to meet Industrial Standards for Performance and Safety. The BP114A model will power single-acting, hydraulic tools.

Special skill, knowledge and training may be required for a specific task and the product may not be suitable for all jobs. The user must ultimately make the decision regarding suitability of the product for any given task and assume the responsibility of safety for all in the work area. Contact a Durapac representative if you are unsure of your power unit's suitability for a particular application.

2.0 Receiving Instructions

It is recommended prior to use that an inspection be done by qualified personnel and that any missing or damaged parts, decals, warning/safety labels or signs are replaced with Durapac authorised replacement parts only. Any power unit that appears to be damaged in any way, is worn, leaking or operates abnormally should be removed from service immediately until such time as repairs can be made. Any power unit that has been or suspected to have been subject to a shock load should be removed from service immediately until inspected by a Durapac authorised service centre. Owners and operators of this equipment should be aware that the use and subsequent repair of this equipment may require specialised training and knowledge.

3.0 Safety

Save these instructions. For your safety, read and understand the information contained within. The owner and operator should understand this product and safe operating procedures before attempting to use this product. Instructions and safety information should be conveyed in the operator's native language before use of this product is authorised. Make certain that the operator thoroughly understands the inherent dangers associated with the use and misuse of the product. If any doubt exists as to the safe and proper use of this product as outlined in this factory authorised manual, remove from service immediately.



DANGER:

- To avoid personal injury keep hands and feet away from work area during operation
- **Do NOT** handle pressurised hoses. Escaping oil under pressure can penetrate the skin causing serious injury. If oil is injected under the skin, see a doctor immediately
- Stay clear of loads supported by hydraulics. A cylinder, when used as a load lifting device, should never be used as a load holding device. After the load has been raised or lowered, it must always be supported mechanically



WARNING:

- The system operating pressure must not exceed the pressure rating of the lowest rated component in the system. Install pressure gauges in the system to monitor operating pressure. It is your window to what is happening in the system

- Always wear appropriate personal protective equipment (PPE) when operating hydraulic equipment. The operator must take precaution against injury due to failure of the tool or work piece(s)
- **Do NOT** hold or stand directly in line with any hydraulic connections while pressurising
- **Do NOT** attempt to disconnect hydraulic connections under pressure. Release all line pressure before disconnecting hoses
- All personnel must be clear before lowering load or depressurising the system
- **Do NOT** attempt to lift a load weighing more than the capacity of the cylinder

**IMPORTANT:**

- If at any stage, the safety related decals become hard to read, these must be replaced
- Minimum age of the operator must be 18 years. The operator must have read and understood all instructions, safety issues, cautions and warnings before starting to operate the equipment. The operator is responsible for this activity towards other persons
- **Do NOT** lift hydraulic equipment by the hoses or couplers. Use the carrying handle or other means of safe transport
- Hydraulic equipment must only be serviced by a qualified hydraulic technician. For repair service, contact the Durapac authorised service centre in your area. To protect your warranty, use only high-quality hydraulic oil

**CAUTION:**

- **KEEP HYDRAULIC EQUIPMENT AWAY FROM FLAMES AND HEAT.** Hydraulic fluid can ignite and burn. Excessive heat will soften packings and seals, resulting in fluid leaks. Heat also weakens hose materials and packings. For optimum performance do not expose equipment to temperatures of 65°C (150°F) or higher. Protect all equipment from weld spatter
- No alteration should be made to this device

3.1 Hydraulic Power Units

- When power tools are used, basic safety precautions must be followed to prevent the risks of fire, electric shock and personal injury
- The pump has a high oil flow rate. This results, especially when driving small tools (diameter of the working piston), high speeds of the working piston. The operator must take suitable protective measures to ensure safe operation of the tools with this power unit
- **Do** use a gauge or other load measuring instrument to verify load
- **Do NOT** exceed the rated capacity of the power unit or any equipment in the system. Burst hazard exists if connection pressure exceeds rated pressure
- **Do NOT** operate the system with bent or damaged couplers or damaged threads
- **Do NOT** subject the power unit and its components to shock loads

- Use only Durapac approved accessories and components
- **Do NOT** connect to an application which can return more oil to the reservoir than the power unit reservoir can hold
- **Do NOT** connect power unit to a hydraulic system that is powered by another pump

3.2 Hydraulic Hoses & Fluid Transmission Lines

- Avoid short runs of straight-line tubing. Straight line runs do not provide for expansion and contraction due to pressure and/or temperature changes
- Reduce stress in tube lines. Long tubing runs should be supported by brackets or clips. Before operating the power unit, connections should be tightened securely and leak-free. Over tightening can cause premature thread failure or high-pressure fittings to burst
- Should a hydraulic hose ever rupture, burst or need to be disconnected, immediately shut off the power unit and release all pressure. Never attempt to grasp a leaking pressurised hose with your hands. The force of escaping hydraulic fluid can inflict injury
- **Do NOT** subject the hose to potential hazard such as fire, sharp objects, extreme heat or cold or heavy impact
- **Do NOT** allow the hose to kink, twist, curl, crush, cut or bend so tightly that the fluid flow within the hose is blocked or reduced. Periodically inspect the hose for wear
- Hose material and coupler seals must be compatible with the hydraulic fluid used. Hoses also must not come in contact with corrosive materials such as battery acid, creosote-impregnated objects and wet paint. Never paint a coupler or hose

FAILURE TO HEED THESE WARNINGS MAY RESULT IN PERSONAL INJURY AS WELL AS PROPERTY DAMAGE.

4.0 Installation



IMPORTANT:

- The power unit is connected by means of a quick coupling via a corresponding pressure hose oil loss free with the tool
- In the event of a fault in the electronic control, the system pressure of the electric pump is limited by a safety pressure relief valve
- The unit cannot be operated without batteries or with defective batteries. Completely discharged batteries must first be fully charged before the unit can be operated
- Use single acting tools only
- Damage to the sealing wax or adjustment of the pressure relief valve may void the warranty
- **Do not** tilt the unit. Always transport and use/operate upright or oil can escape through the vent screw

- 4.1 Familiarise yourself with the specifications and illustrations in this owner’s manual. Know your power unit, its limitations and how it operates before attempting to use. Refer to the technical data below or if in doubt, contact a Durapac representative.

Pump Type	Single-stage three-cylinder radial piston pump
Pump Outputs / Inputs	1 / 1
Oil Flow	0.42 – 1.02 Lpm (nominal)
Max. Oil Volume (approx.)	1,400 cc
Usable Oil Volume (approx.)	1,000 cc
Maximum Pressure	700 bar
Oil Type	Durapac Hydraulic Oil (DHO-10L)
Drive	DC motor 48 Volts (max. 58 V)
Motor Peak Power	1,400 Watts
Battery Capacity	7,830 mAh
Dimensions W x L x H (approx.)	185 x 250 x 270 mm
Weight (approx.)	6.5 kg
Power Supply Unit	primarily 230 V ~, secondary 24 V, 5 A
Max. Operating Conditions	-20 ° C to + 40 ° C
Environmental Conditions	0 to 100% rel. humidity
Noise Level	< 70 dBA
Degree of Protection According to EN 60529	IP23
Operating Mode Intermittent Operation	30% ED

- 4.2 Power Unit - Ensure power unit is turned off and is on a firm, stable, level surface. An inclination of not more than 15° is permitted. If the unit is operated in an elevated position (> 0.5m above ground), it must be secured against falling. Please note that the hydraulic hose may cause pulling forces on the unit.
- 4.3 Oil - Your cordless electrohydraulic unit comes ready to use. The unit is filled with oil and can be used immediately. If the oil is supplied separately, the unit must be filled with oil before starting.
- 4.4 Battery Pack - The power unit has a powerful lithium-ion battery. The lifetime is designed for at least 500 complete charging cycles. The battery must be replaced by the manufacturer or authorized dealer. The state of charge of the battery can be read on start up on the display. In addition, an LED (green/amber/red/blue) light indicates the charge status. If the unit is used as part of a safety cutting system, the battery LED must light green (> 66 %) before a cut is initiated.
- 4.5 Remote Control – The unit is supplied with both the corded and wireless remote pendants. Operation is the same for both.

4.6 Connect remote control and charger



- A. Plug the cable remote control into the socket. The remote control will now operate your unit, or
- B. Plug charger into the socket.

Control Panel	
A.1.	<p>BATTERY Indicates the battery's remaining voltage.</p> <p>Green = Battery charge > 66%. Amber = Battery charge 65% - 34%. Red = 33% - 16% Charge the battery. Red flashing = 15% - 0% Charge the battery. Acoustic warning every 15 seconds. Unit may shutdown. Blue flashing = Charging (< 99%). Green flashing = Charging complete (100%).</p>
A.2.	<p>SYSTEM Indicates system status.</p> <p>Green = System is ready for operation. Red = System Error (over temperature, over current consumption, etc.). No LED = System is not ready for operation.</p>
A.3.	<p>MOTOR Indicates motor status.</p> <p>No LED = Motor stopped. Green = Motor/unit is running (& button on remote control is pressed) Blue = Pressure held, release pressure by momentary press of the Green Remote-Control button.</p>

A.4.	<p>REMOTE CONTROL Colours are shown in descending priority, higher priority overrides lower. Blue = Wireless Remote-Controlled/Blue tooth paired. Blue flashing = Blue tooth pairing. Green = Wired remote control connected.</p>
A.5.	<p>SERVICE REQUIRED No LED = Service not required. Red = Service Required. Contact your local Durapac authorised service centre.</p>
B.	<p>MODE Mode is toggled by pressing the + and – buttons. Mode 1: ON – 700 bar operating mode. Mode 2: If enabled, can be customised {Auto-Retract, Adjustable Pressure Cut-off}. Contact your local Durapac authorised service centre for further details.</p>
C.	<p>BAR Displays the pressure. If adjustable pressure function is enabled, this will display the pressure setting. After completing an operation, the cut-off pressure will be displayed for a few seconds. During start-up, the software version and state of charge, eg. “55%” will be displayed.</p>
D.	<p>POWER Turn on the unit by pressing and holding the blue button. The unit will go through a self-test. The current pressure will then be displayed. The display will fluctuate between 0-15 bar. This is systemic and fine. When on, pressing and holding the blue button will turn off the unit.</p>

4.7 Connect the hydraulic tool to the quick coupling - To connect the tool to the quick coupling, first remove the protective cap. To engage or disengage the coupling connection, slide the sliding sleeve on the quick coupling as far as it will go. The connection is made without oil loss. The connection is correct if the red ring of the coupling is no longer visible.

 **ATTENTION** - Make sure that the coupling is only coupled in a depressurised condition.

4.8 After uncoupling the tool, always put on the cap. The couplings must be clean when plugged in, as introduced dirt particles can damage the pumping elements.

4.9 Before uncoupling the hose and tool, always return the working piston of the tools to their initial positions. As a result, the oil flows back from the tool cylinder into the pump. This prevents oil loss of the pump.

4.10 Make sure that the plug-in coupling is fully engaged.

5.0 Operation



IMPORTANT:

- Always monitor pressure, load or position using suitable equipment. Pressure may be monitored by means of an optional manifold and gauge. Correct application position

can only be determined by the operator of the equipment

- **Do NOT** operate a power unit that is disconnected from the application. If operated in this condition, the hose and connections will become pressurised. This increases the chance of a burst hazard. Damage may also occur to the power unit and its components
- Before each operation, the operator must make sure that the power unit is in perfect condition, in particular the pressure hose, the plug-in connectors and the connected tool

5.1 Battery or Mains Operation

5.1.1 **Charging the battery** – The charger / power supply requires a 230 V, 50/60 Hz power supply, which is secured with at least 10 A to charge the unit.

- A. Connect the power supply to unit.
- B. Connect the mains plug to the mains. The LED indicator of the charger will light up, the unit will start automatically and the fan will start. When charging, the LED (1) on the display will flash blue. When the battery is fully charged, the LED (1) will flash green.
- C. To switch off, the charging cable must be disconnected. The LED on the charger turns off after 15 seconds.

5.1.2 **Operate the unit in battery mode** – Turn on the unit by pressing down and holding the blue power button on the Control Panel for 3 seconds. After 10 minutes in standby mode, the unit will automatically switch off to save energy.

5.1.3 The battery capacity is sufficient for one day of assembly work. You can work without charging until the battery LED lights up/flashes red.

5.1.4 If the battery LED flashes red, the unit must then be charged before it can be put back into operation.

5.1.5 In battery mode, the unit can be shut down by pressing and holding down the blue power button on the Control Panel for 3 seconds.

5.2 Power On/Off - Control Panel

5.2.1 To switch power on or off, press and hold (for 3 seconds) the Blue Power button on the Control Panel.

5.2.2 After use or during longer breaks, the unit should be switched off for safety reasons. After about 10 minutes in standby mode, the unit automatically shuts off to save energy.

5.2.3 The Green (+) or Red (-) buttons on the Control Panel will select the desired saved program. If activated, you can switch between the program selection and the pressure adjustment with a short press of the blue button. The red dot at the bottom of the display marks the currently active function (see below table/screen shots). The cut-off pressure can also be set with the + and - buttons.



- ⚠ ATTENTION: For reasons of occupational safety, the closing speed of the connected tools must not exceed 10 mm / s without additional safeguards

5.3 Remote Control

- ⚠ The range of the Radio Remote Control is approximately 10 meters
- ⚠ If the LED on the remote-control flashes red, the battery of the radio remote control must be changed



- 5.3.1 When the **green** button is pressed, the solenoid valve of the pressure output is energised. After a switch-on delay of approx. 0.2 seconds, the motor will start, the unit will build up pressure and the working piston of the connected tool will start to move.
- 5.3.2 The green LED on the remote-control signals a [green] button press.
- 5.3.3 The flow and return of the connected tool are controlled by means of a control valve on the tool.
- 5.3.4 When the button is released, the motor will stop and pressure is held. A second short press on the jogging control will cause the pressure to be released and the tool to return.
- 5.3.5 By continuously pressing the switch again, the motor will start up again and the operation will continue.
- 5.3.6 If optional auto return function is enabled, when green button is released, pressure will be released.

Note – The red button is not used with BP114A.

5.4 Pressure Limitation

When the nominal pressure is reached, the unit switches off automatically.

5.5 Pairing of the Radio Remote Control

The unit is delivered with an already coupled radio remote control. To pair a new radio remote control, perform the following steps:

- A. Open the new radio remote control.
- B. Turn on the unit and, if connected, disconnect the cable for the remote control.
- C. On the display of the unit, press and hold the Green (+) and Red (-) buttons at the same time until the LED (4) on the display flashes blue.
- D. In the wireless remote control, press the pairing button (next to the battery holder). The LED of the remote control will start flashing blue. Pairing can take up to 30 seconds.
- E. After successful connection, the LED (4) on the display light up solid blue.
- F. In the event of a fault, the LED (4) on the display goes out. It may be necessary to repeat the pairing process.

6.0 Maintenance



IMPORTANT:

- Check oil level regularly
- Use only good quality hydraulic fluid. **Do NOT** use brake fluid, transmission fluid, turbine oil, motor oil, alcohol, glycerine etc. Use of anything other than good quality hydraulic oil will void warranty and damage the power unit, hose, and application. We recommend Durapac Hydraulic Oil or equivalent. Some applications such as cable spiking require special oils. Refer to your authorised distributor for details
- Equipment must only be serviced by a qualified hydraulic technician. For repair service, contact your local Durapac authorised service centre
- Damage to hydraulic hoses may not be detected during visual inspections. For this reason, Durapac recommends that hydraulic hoses be replaced on a regular basis
- Tighten connections as needed. Use non-hardening pipe thread compound when servicing connections
- Before opening the housing of the hydraulic pump, the power unit must be switched off and the mains plug must be removed
- Unused devices should be switched off, kept in a dry, locked place and out of the reach of children
- The electrical equipment may only be maintained by a recognized electrician
- Do not manipulate the unit, remove parts or replace them with foreign parts

Dirt, sand, etc. will quickly ruin any hydraulic system. Ensure that couplings are clean and free of foreign matter. After each use, clean couplings and attach dust caps.

Maintenance is required when wear or leakage is noticed. Periodically inspect all components to detect any problem that may require service and maintenance.

6.1 Adding Hydraulic Fluid

- ⚠ **WARNING:** Always add oil with cylinders fully retracted (or extended, if pull cylinders) or the system will contain more oil than the reservoir can hold
- ⚠ The unit is delivered, filled with oil to approx. 1,000 ccm
- ⚠ The pump has a closed oil circulation system. If the operated tools are properly returned to their original position after use, the oil level should only be checked with the safety test required every 2 years



- 6.1.1 Depressurise and disconnect hydraulic hose from application/cylinder.
- 6.1.2 With the power unit in its upright, horizontal position, remove the air vent plug located on the top plate of the reservoir (this is accessed by removing the top section of the unit casing).
- 6.1.3 Take out the filling plug.
- 6.1.4 Use a small funnel to fill the reservoir to within 19mm (3/4") of the opening.
- 6.1.5 Bleed air from system if necessary.

- 6.1.6 Wipe up any spilled fluid and reinstall the air vent plug/reservoir cap.

6.2 Bleeding Air from the System

- 6.2.1 Repeat Steps 6.1.1 to 6.1.4 (above), if required.
- 6.2.2 Using a hydraulic hose, open coupling into the reservoir. Operate the unit until a steady stream of air free oil is seen. Disconnect the open coupling and couple to a suitable hydraulic cylinder.
- 6.2.3 Extend and retract the cylinder several times putting a load on the system. Any remaining air will be released into the power unit reservoir.
- 6.2.4 Recheck oil level after removing air.

6.3 Changing Hydraulic Fluid

-  For best results, change fluid once a year or every 300 hours of use
-  Depending on the frequency and type of use of the unit, the oil level must be checked. If necessary, top up with oil.
-  The oil should be changed at least every two years or more regularly depending on the conditions of use.
- 6.3.1 Repeat Steps 6.1.1 to 6.1.3 (above).
- 6.3.2 Pour used fluid into a sealable container.
- 6.3.3 Repeat Steps 6.1.4 to 6.1.5 (above).
- 6.3.4 Dispose of fluid in accordance with local regulations.

6.4 Maintaining the Battery

Li-ion batteries have a long life if properly maintained. To maximise the service life, please observe the following:

- 6.4.1 The battery should be recharged after each use. To do this, connect the pump to the mains.
- 6.4.2 Even if the pump is not used for a long time, connect the pump to the mains. Batteries cannot be overcharged, even if the power supply is connected for a long time.
- 6.4.3 The battery **must not** be fully discharged.
- 6.4.4 Protect batteries from high temperatures. Do not store the unit in direct sunlight. Temperatures above 40°C will decrease the battery life.
- 6.4.5 Every three months, the pump should be discharged to at least 60%.

6.5 Storage

- 6.5.1 When not in use, depressurise and disconnect the power unit from the application.

- 6.5.2 Wipe clean thoroughly and store in a clean, dry environment. Avoid temperature extremes.
- 6.5.3 For transportation or long storage, replace the air vent plug with shipping plug.
- 6.5.4 Shield power unit with a protective cover.

6.6 Shipping Instructions

The unit must be declared as dangerous goods because it contains hydraulic oil and has a Li-Ion battery. For shipping, the hydraulic unit and the associated tools must be packed and shipped upright.

7.0 Troubleshooting

Problem	Cause	Solution
Unit starts, but shuts off immediately	High pressure hose not connected correctly	<ul style="list-style-type: none"> • Check quick coupling •
The unit does not start when the button is pressed	Battery of the wireless remote-control is empty	<ul style="list-style-type: none"> • Replace wireless remote-control battery
	No connection of the remote-control cable	<ul style="list-style-type: none"> • Check remote-control connection
	Hose not connected	<ul style="list-style-type: none"> • Check hose connection
	Battery is empty	<ul style="list-style-type: none"> • Recharge the battery
Unit is running but without sufficient pressure/piston travel is too low	Solenoid valve defective	<ul style="list-style-type: none"> • Contact a Durapac authorised service centre for repair
	Oil quantity is insufficient (tool too large)	<ul style="list-style-type: none"> • Contact a Durapac authorised service centre for repair
The unit works but does not apply pressure	Air in the system	<ul style="list-style-type: none"> • Connect hose and tool to the pump • Turn the pump downwards with the coupling • Run the pump several times • The air will escape into the tank and it can be worked again • If it occurs more frequently, the unit should be returned for service
	The connected hose is not filled with oil	<ul style="list-style-type: none"> • Please follow the steps in 6.2 – Bleeding Air from the System in the Maintenance Section
Unit seems normal, but shutdown pressure is too low	Pressure limitation is adjusted	<ul style="list-style-type: none"> • Contact a Durapac authorised service centre for repair
The working pressure is not reached and the battery LED is red	The battery capacity is insufficient	<ul style="list-style-type: none"> • Recharge the battery
Ultimate pressure is reached only very slowly or not at all	Pumping elements defective	<ul style="list-style-type: none"> • Contact a Durapac authorised service centre for repair
	Solenoid valve defective	<ul style="list-style-type: none"> • Contact a Durapac authorised service centre for repair
	Battery is empty	<ul style="list-style-type: none"> • Recharge the battery
LED of the radio remote control flashes red	The battery is empty	<ul style="list-style-type: none"> • Replace the radio remote-control battery

8.0 Error Codes

Error Code # / Type	Description	Solution
100 / Error	Invalid system configuration	<ul style="list-style-type: none"> • Switch off the unit and rectify the error
101 / Error	Missing program configuration	<ul style="list-style-type: none"> • Switch off the unit and rectify the error
102 / Error	Overpressure detected	<ul style="list-style-type: none"> • Switch off the unit and rectify the error
103 / Error	Hydraulic oil temperature too high	<ul style="list-style-type: none"> • Switch off the unit and allow to cool
200 / Error	Invalid pressure sensor voltage readings detected	<ul style="list-style-type: none"> • Switch off the unit and rectify the error
800 / Warning	Pressure rise too high	<ul style="list-style-type: none"> • Check the hydraulic hose connection • Confirm to continue with OK button
801 / Warning	Temperature motor control too high	<ul style="list-style-type: none"> • Allow the unit to cool • Confirm to continue with OK button
802 / Warning	Current consumption motor too high	<ul style="list-style-type: none"> • Allow the unit to cool • Confirm to continue with OK button
803 / Warning	High motor current consumption detected over a longer period of time	<ul style="list-style-type: none"> • Allow the unit to cool • Confirm to continue with OK button
804 / Warning	Battery temperature outside the permissible temperature range	<ul style="list-style-type: none"> • Allow the unit to cool • Confirm to continue with OK button
805 / Warning	Battery voltage far too low	<ul style="list-style-type: none"> • Charge battery immediately • Confirm to continue with OK button

9.0 Parts Breakdown and List

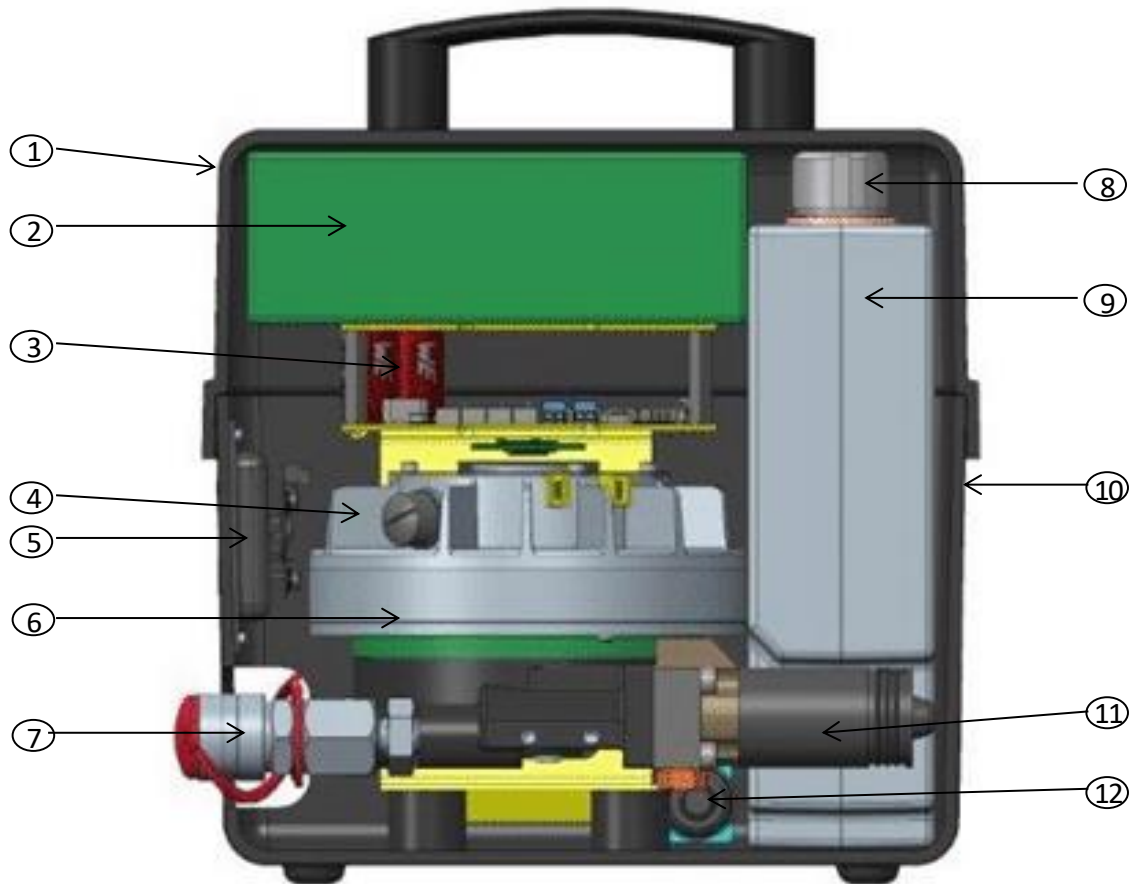

Serial, model and item numbers need to be quoted when ordering parts.

Item	Description
1	Upper body
2	Battery
3	Control
4	Engine
5	Control panel (complete)
6	Engine gasket
7	Coupling sleeve
8	Bleed screw
9	Reservoir
10	Housing
11	Solenoid valve
12	Pressure sensor