

THE **DPR-SERIES** ROTARY AIR DRIVEN POWER UNITS ARE A TWO SPEED HIGH PERFORMANCE PUMP DESIGN.

They are ideally suited to applications where air is the preferred power source. A choice of valve configurations allows them to be used with single or double acting cylinders and tools. Optional valve sub-plates offer pressure and flow control. All models feature a heavy duty air motor with a motor ON/OFF air supply valve and 7.2 L usable oil reservoir.



DPR-174

DPR-173

Model No.	Used with Cylinder	Motor Size (kW)	Usable Oil Capacity (L)	Maximum Pressure Rating (bar)	Pressure Rating (bar)		Oil Output Flow Rate (Lpm)		Valve Type
					1st Stage	2nd Stage	1st Stage	2nd Stage	
DPR-173	S/A	1.27	7.2	700	22	700	4.0	0.3	Manual 2w/2p
DPR-174	D/A	1.27	7.2	700	22	700	4.0	0.3	Manual 4w/3p



Durapac offers a range of optional sub-plates and directional control valves to suit the DPR-Series air driven power units.

1 Optional air actuated directional control valves, 3 & 4 way versions available.

2 Optional pilot check valve sub-plate.

3 Optional adjustable pressure relief valve sub-plate.

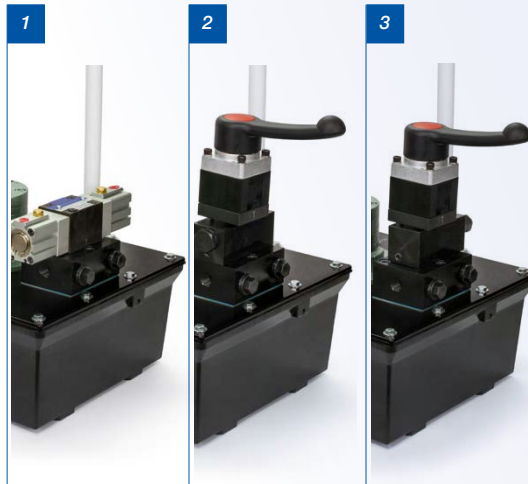

DPR-173

Manual 2 way/2 position valve for Advance/Hold*/Retract of single acting cylinder/tool.

PERFORMANCE CHART

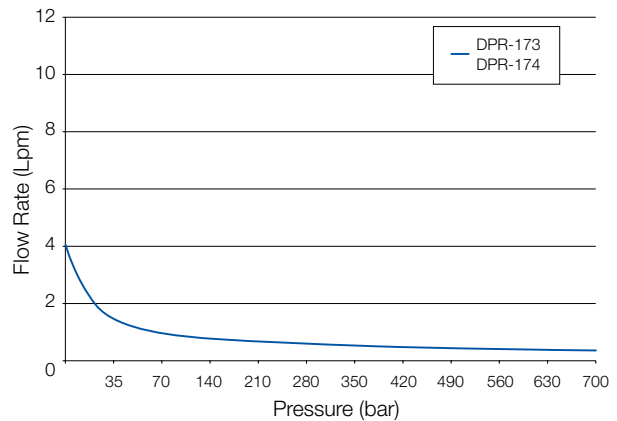

DPR-174

Manual 4 way/3 position valve for Advance/Hold/Retract of a double acting cylinder/tool. Valve handle detent operation.

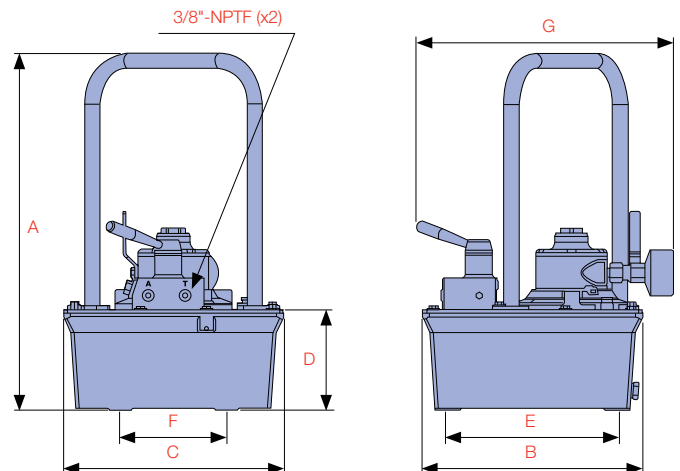

Valve Function	Air Pressure Range (bar)	Air Consumption (Lpm)	Sound Level (dB)	Dimensions (mm)							Weight (kg)
				A	B	C	D	E	F	G	
Advance/Hold*/Retract	5.6 - 7.0	1,246	93	504	312	312	141.5	251	149.4	363	21.5
Advance/Hold/Retract	5.6 - 7.0	1,246	93	504	312	312	141.5	251	149.4	408	22.0

* HOLD in ADVANCE position with motor OFF