

DURAPAC
ENGINEERED FOR RELIABILITY

Instruction Manual

100 Ton Hydraulic Puller
Model – DHP-100E



Maximum Operating Pressure – 700 bar



This is a safety alert symbol. It is used to alert you to potential personal injury hazards. Obey all safety messages that follow this symbol to avoid injury or death

1.0 Product Information

DURAPAC – Hydraulic Pullers are engineered to meet Industrial Standards for Performance and Safety. The DHP-100E model uses a double acting hydraulic system for holding, opening & closing jaws; providing a safe and secure grip at all times. They also feature the following:

- Flow metering system provides constant lowering speed
- Single acting, spring return, 100 ton capacity cylinder
- Easy jaw head adjusting system prevents puller jaws from sliding
- Puller can be assembled in 2 or 3 jaw configuration
- Puller can be adjusted 5 degrees up or down of puller centreline for precise positioning
- Castors provide easy cart movement
- Includes electric power unit with 230V single phase or 380V three phase options
- Includes four extensions

Special skill, knowledge and training may be required for a specific task and the product may not be suitable for all jobs. The user must ultimately make the decision regarding suitability of the product for any given task and assume the responsibility of safety for all in the work area. Contact a Durapac representative if you are unsure of your puller's suitability for a particular application.

2.0 Receiving Instructions

It is recommended prior to use that an inspection be done by qualified personnel and that any missing or damaged parts, decals, warning/safety labels or signs are replaced with Durapac authorised replacement parts only. Any puller that appears to be damaged in any way, is worn, leaking or operates abnormally should be removed from service immediately until such time as repairs can be made. Any puller that has been or suspected to have been subject to a shock load should be removed from service immediately until inspected by a Durapac authorised service centre. Owners and operators of this equipment should be aware that the use and subsequent repair of this equipment may require specialised training and knowledge.

3.0 Safety

Save these instructions. For your safety, read and understand the information contained within. The owner and operator should have an understanding of this product and safe operating procedures before attempting to use this product. Instructions and safety information should be conveyed in the operator's native language before use of this product is authorised. Make certain that the operator thoroughly understands the inherent dangers associated with the use and misuse of the product. If any doubt exists as to the safe and proper use of this product as outlined in this factory authorised manual, remove from service immediately.



DANGER:

- To avoid personal injury keep hands and feet away from work area during operation
- **Do NOT** handle pressurised hoses. Escaping oil under pressure can penetrate the skin causing serious injury. If oil is injected under the skin, see a doctor immediately

- Stay clear of loads supported by hydraulics. A cylinder, when used as a load lifting device, should never be used as a load holding device. After the load has been raised or lowered, it must always be supported mechanically

**WARNING:**

- The system operating pressure must not exceed the pressure rating of the lowest rated component in the system. Install pressure gauges in the system to monitor operating pressure. It is your window to what is happening in the system
- Always wear appropriate personal protective equipment (PPE) when operating hydraulic equipment. The operator must take precaution against injury due to failure of the tool or work piece(s)
- **Do NOT** hold or stand directly in line with any hydraulic connections while pressurising
- **Do NOT** attempt to disconnect hydraulic connections under pressure. Release all line pressure before disconnecting hoses
- All personnel must be clear before lowering load or depressurising the system
- **Do NOT** attempt to lift a load weighing more than the capacity of the cylinder

**IMPORTANT:**

- If at any stage, the safety related decals become hard to read, these must be replaced
- Minimum age of the operator must be 18 years. The operator must have read and understood all instructions, safety issues, cautions and warnings before starting to operate the equipment. The operator is responsible for this activity towards other persons
- **Do NOT** lift hydraulic equipment by the hoses or couplers. Use the carrying handle or other means of safe transport
- Hydraulic equipment must only be serviced by a qualified hydraulic technician. For repair service, contact the Durapac authorised service centre in your area. To protect your warranty, use only high quality hydraulic oil

**CAUTION:**

- **KEEP HYDRAULIC EQUIPMENT AWAY FROM FLAMES AND HEAT.** Hydraulic fluid can ignite and burn. Excessive heat will soften packings and seals, resulting in fluid leaks. Heat also weakens hose materials and packings. For optimum performance do not expose equipment to temperatures of 65°C (150°F) or higher. Protect all equipment from weld spatter
- No alteration should be made to this device

3.1 Hydraulic Pullers

- Align the puller on the same centreline as the part being removed. Failure to align the parts correctly can result in a dangerous operating situation because of the high hydraulic pressure used. Self-centring models can be aligned on the centreline after the pullers fully engaged with the part

- Before applying pressure, wrap the work in a safety blanket/ sheath to protect from injury caused by flying parts should a part ever break
- **Do NOT** heat the part to be removed. When the puller comes in contact with the part, heating can result in damage to components of the puller
- Apply force gradually
- Ensure that the puller jaws are fully engaged with the workpiece being pulled
- **Do NOT** overload equipment. Overloading can cause equipment failure and possible personal injury. **Do** use a gauge or other load measuring instrument to verify load
- This device is not suitable for use as a support device! As the system load is lifted, use blocking and cribbing to guard against a falling load
- **Do NOT** over extend the puller
- Only operate within the limits of the pullers' rated stroke
- **Never** pressurise uncoupled couplers. Only use hydraulic equipment in a coupled system
- Use only Durapac approved accessories and components

3.2 Hydraulic Hoses & Fluid Transmission Lines

- Avoid short runs of straight line tubing. Straight line runs do not provide for expansion and contraction due to pressure and/or temperature changes
- Reduce stress in tube lines. Long tubing runs should be supported by brackets or clips. Before operating the pump, connections should be tightened securely and leak-free. Over tightening can cause premature thread failure or high pressure fittings to burst
- Should a hydraulic hose ever rupture, burst or need to be disconnected, immediately shut off the pump and release all pressure. Never attempt to grasp a leaking pressurised hose with your hands. The force of escaping hydraulic fluid can inflict injury
- **Do NOT** subject the hose to potential hazard such as fire, sharp objects, extreme heat or cold or heavy impact
- **Do NOT** allow the hose to kink, twist, curl, crush, cut or bend so tightly that the fluid flow within the hose is blocked or reduced. Periodically inspect the hose for wear
- Hose material and coupler seals must be compatible with the hydraulic fluid used. Hoses also must not come in contact with corrosive materials such as battery acid, creosote-impregnated objects and wet paint. Never paint a coupler or hose

FAILURE TO HEED THESE WARNINGS MAY RESULT IN PERSONAL INJURY AS WELL AS PROPERTY DAMAGE.

4.0 Installation

- **IMPORTANT:** Always secure threaded port connections with high grade, non-hardening pipe thread sealant. Teflon tape can be used if only one layer of tape is used and it is applied carefully, two threads back, to prevent the tape from being introduced into hydraulic system, which could cause jamming of precision-fit parts

4.1 Familiarise yourself with the specifications and illustrations in this owner’s manual. Know your puller, its limitations and how it operates before attempting to use. Refer to the specification chart below or if in doubt, contact a Durapac representative.

Model Number	Stroke (mm)	Pull Capacity (ton)	Min. Spread (mm)	Max. Spread (mm)	Reach at Min. Spread (mm)	Reach at Max. Spread (mm)	Weight (kg)
DHP-100E	270	100	300	1,500	1,220	952	1,083

4.2 Make hydraulic connections.

- **IMPORTANT:** Fully hand-tighten all couplers. Loose coupler connections will block the flow of oil between the pump and the puller

4.3 Check all system fittings and connections to be sure they are tight and leak free.

4.4 Check oil level in reservoir before operating pump.

4.5 Remove air from the system – Position the puller so that the piston rod is pointed down and the cylinder is lower than the pump. Advance and retract the cylinder several times, avoiding pressure build-up. Air removal is complete when the cylinder motion is smooth.

5.0 Operation

Note - This puller has a 2/3-way combination puller head. The 3-way combination is strongly recommended whenever the job space allows as three jaws give a more secure grip and more even pulling force.

5.1 Setting up the Puller

- 5.1.1 Select the proper size and capacity of the puller needed for the job. This is determined by measuring the 'reach' and the 'spread' of the part to be pulled. Refer to the table in 4.1.
- 5.1.2 Connect the electric hydraulic pump to a suitable 230 Volt 15 amp power outlet. Ensure the flow control valves are in the original locked position. These flow control valves will ensure a steady raising and lowering of the trolley.

5.2 Adjusting Trolley Height/Puller Alignment

- 5.2.1 Use the control panel valve handles to adjust the trolley's vertical alignment (see Figure 1). Note the position of the directional control valves on both the power unit and the control panel (A, B, C).

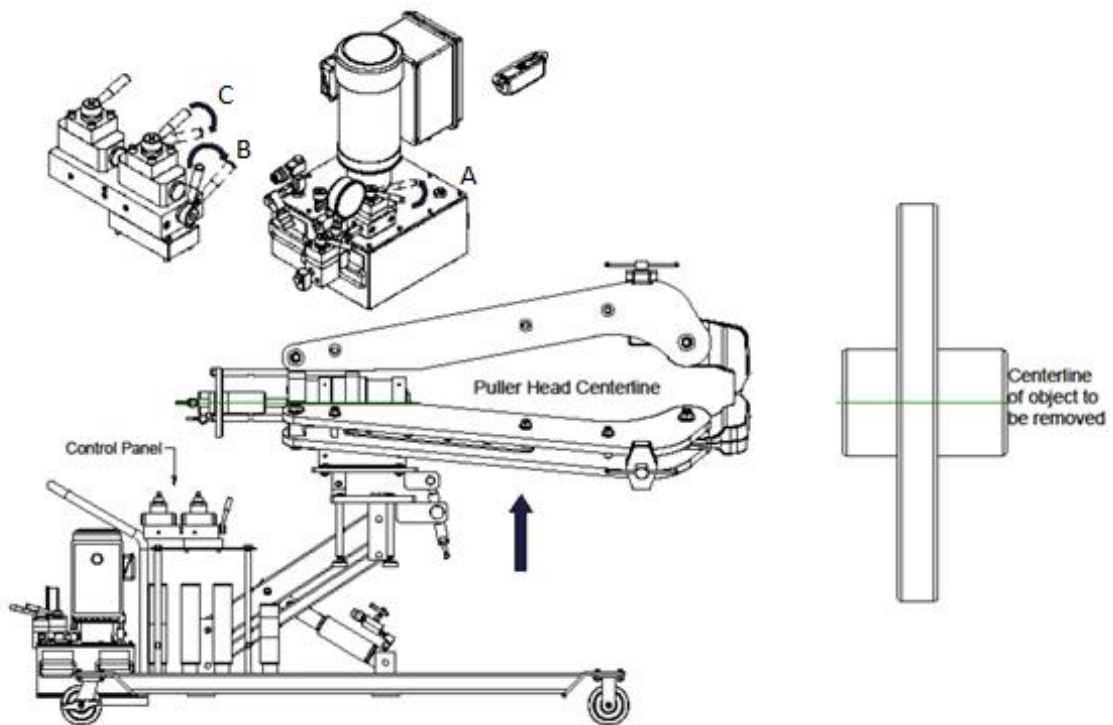

Figure 1 – Puller Alignment

- 5.2.2 Press the remote switch to raise the trolley. The centreline of the work piece must be on the same centreline as the puller head. Align the puller horizontally and vertically as close as possible to the same centerline as the object to be pulled. **Note** – trolley can be lowered, if required, by opening valve B.

5.3 Adjusting Puller Arms

- 5.3.1 Switch the control panel valve handles (see Figure 2) and press the button on the remote switch to open the jaws enough to fit over the work.

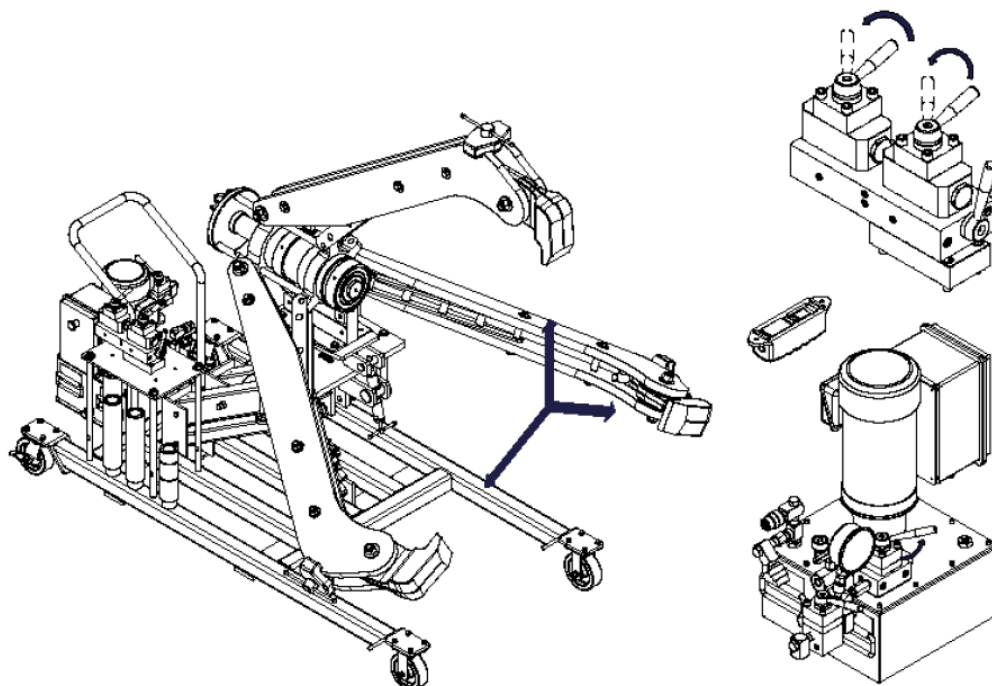

Figure 2 – Adjusting the Puller Arms

- 5.3.2 Rotate the round handle under the puller in a clockwise direction when angled down and in a counterclockwise direction when angled up to ensure the puller head is on the same centreline as the object to be pulled (see Figure 3).

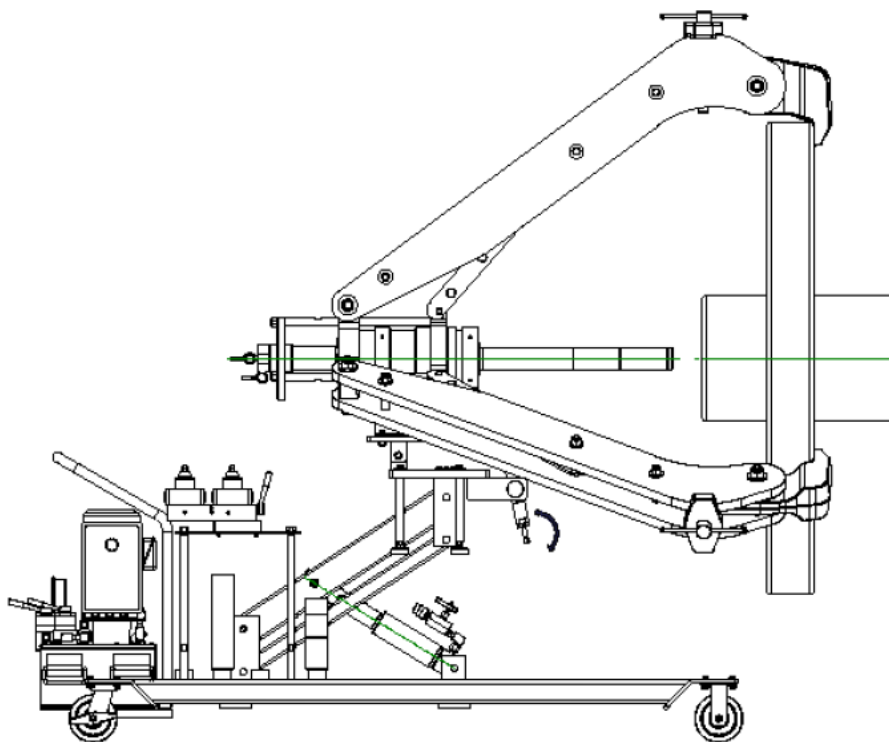

Figure 3 – Adjusting the Puller Head

- 5.3.3 Switch the control panel as shown in Figure 4-1 to tightly close the jaws around the part to be pulled and ensure the jaws are fully engaged and secure (see Figure 4-2).

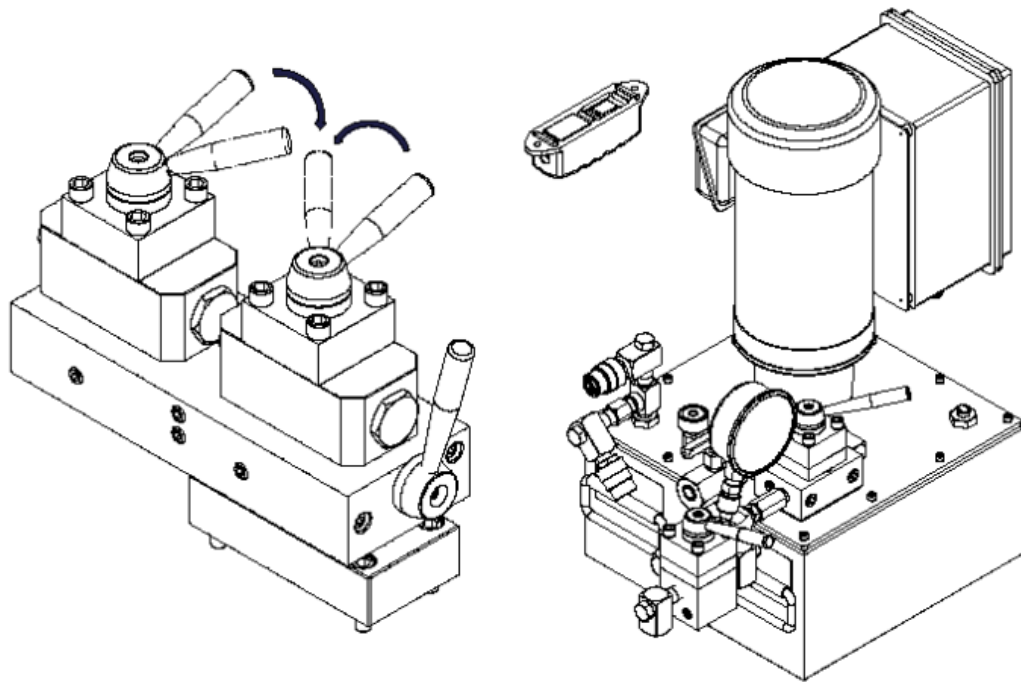

Figure 4-1 – Closing the Puller Jaws

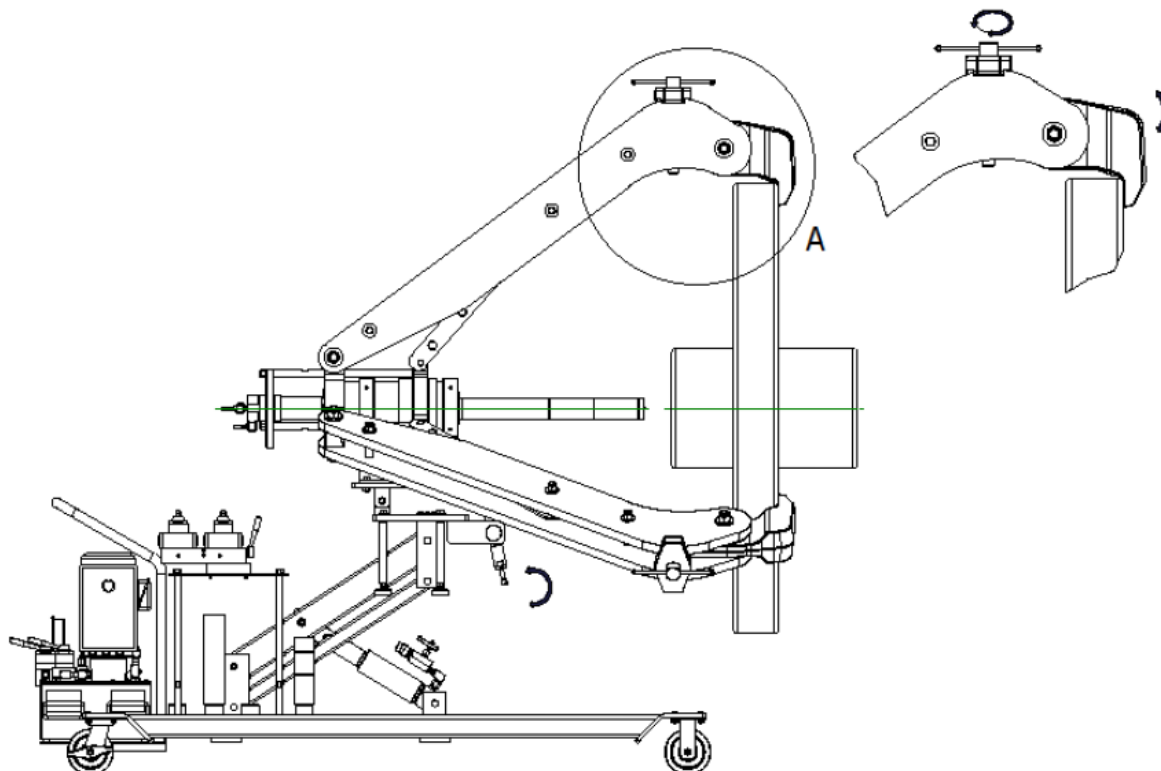

Figure 4-2 – Fully Engaged Jaws

5.3.4 Add as many adaptors as practical to the forcing cylinder (see Figure 5).

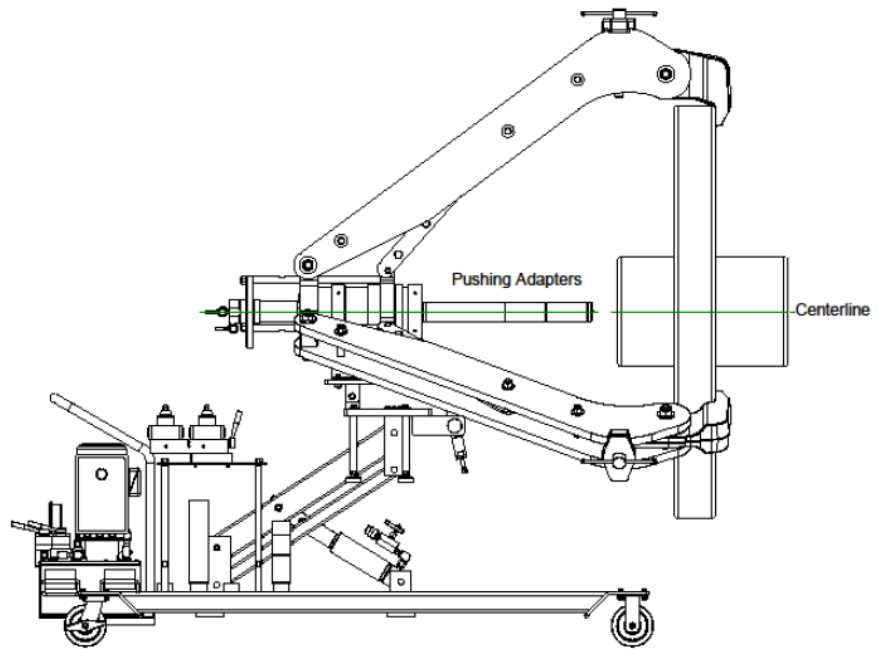

Figure 5 – Adding Adaptors

5.3.5 Note the position of the directional control valves on the power unit. The Selector valve handle should be moved to the PULL CYL. Position and the Pull Cylinder valve should be moved to the ADVANCE position.

5.3.6 Once the puller is aligned, press the button on the remote switch to advance the forcing cylinder (PULL CYL.) toward the object, stopping just as the cylinder head touches the shaft (see Figure 6).

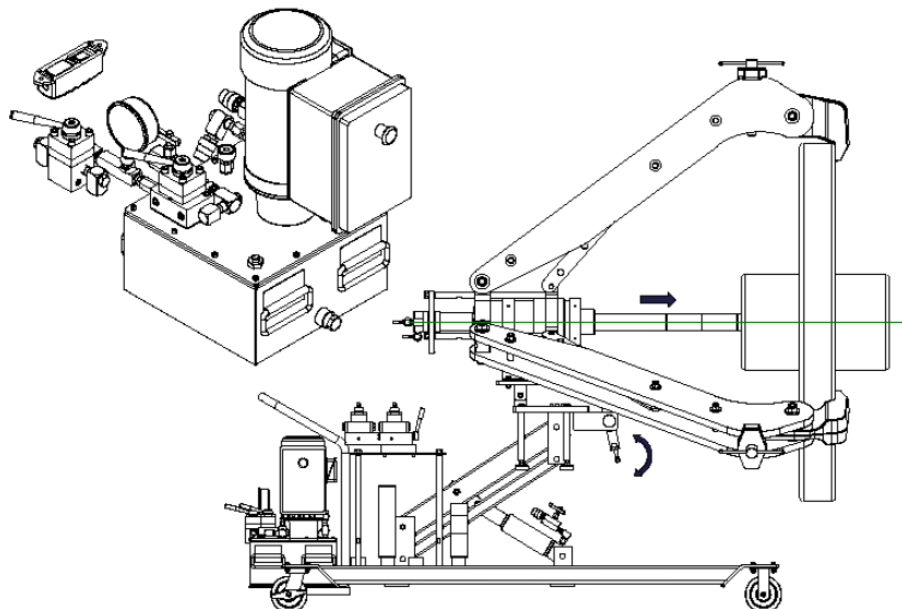

Figure 6 – Advancing the Forcing Cylinder

5.3.7 At the point that the cylinder head contacts the shaft, release the button and inspect the puller and workpiece for proper alignment.

5.3.8 Ensure a support is attached to the work that is to be pulled.

5.4 Operating the Puller

- 5.4.1 Stand behind and to one side of the puller. Continue with pulling job by pressing the button on the remote switch (see Figure 7).

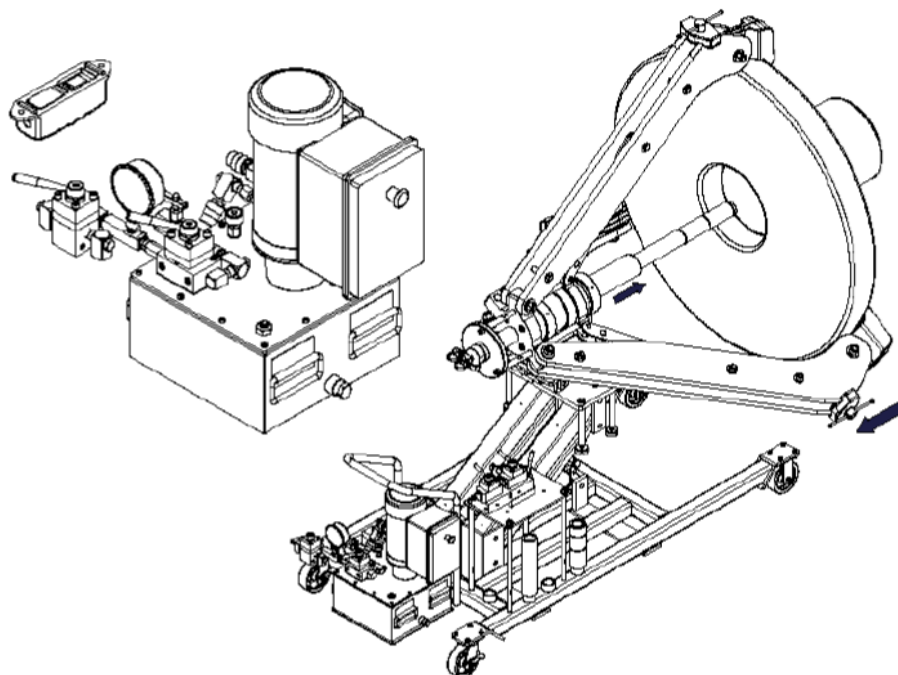

Figure 7 – Operating the Puller

- 5.4.2 If the full stroke has been reached but the object has not been pulled completely, move the Pull Cylinder Valve to the retract position to retract the cylinder (see Figure 8). The pump does not need to be running during retraction. Another adaptor may be added while maintaining the gripping action of the jaws on the object.

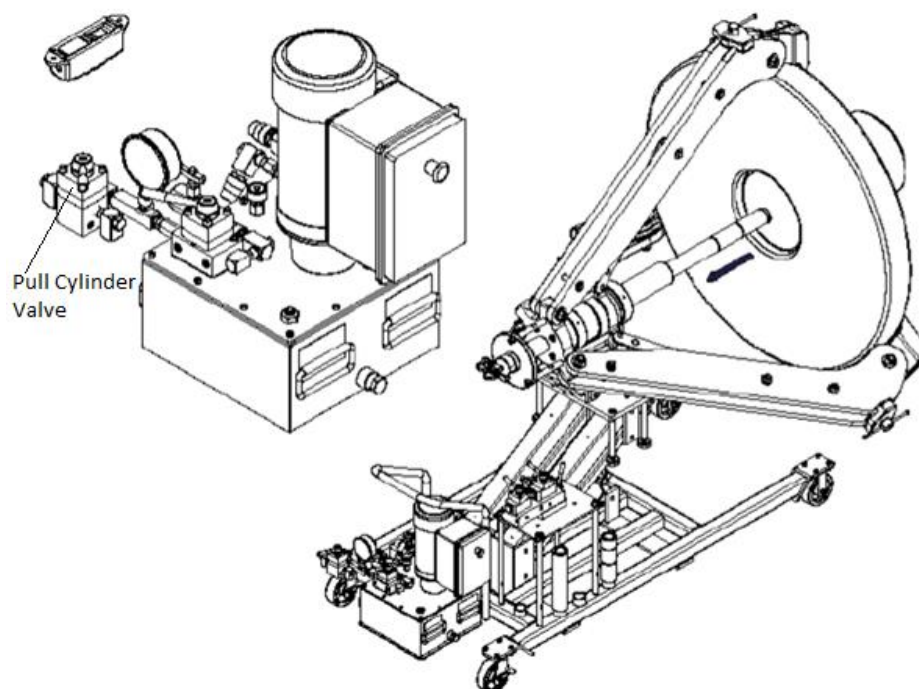

Figure 8 – Retract the Cylinder Piston

- 5.4.3 Switch the power unit and control panel valve handles (A, C, D) as shown in Figure 9 to open the jaws.

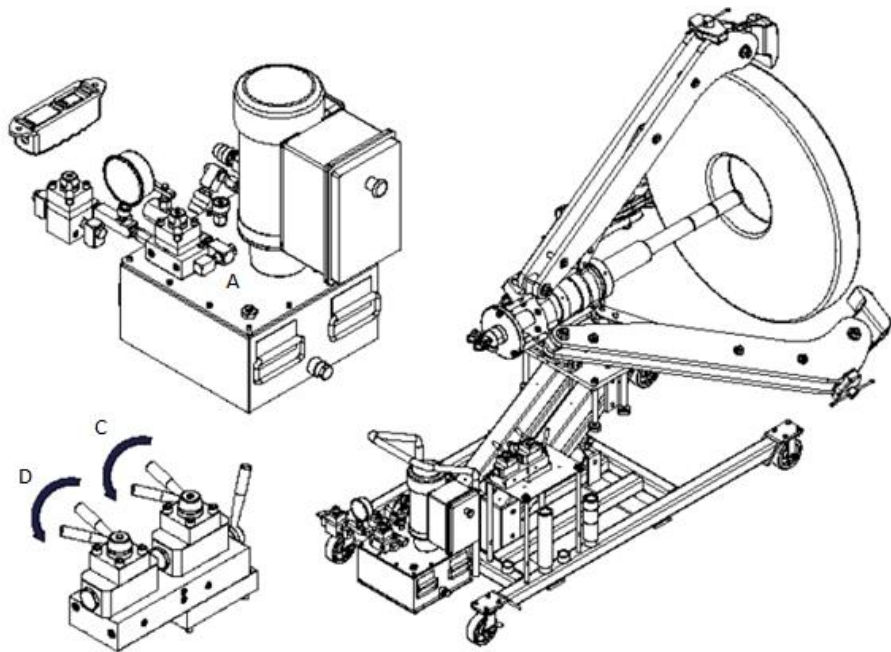

Figure 9 – Opening the Jaws

5.5 Conversion of 3-Jaw Puller to 2-Jaw Puller

Note - The 3-way combination is always followed whenever the job space allows for it because three jaws give a more secure grip and more even pulling force

Remove two sets of jaw and straps located on either side, away from the two symmetrical sections. Reassemble one set of jaw and straps on the other symmetrical section on the crosshead.

6.0 Maintenance



IMPORTANT:

- Use only good quality hydraulic fluid. **Do NOT** use brake fluid, transmission fluid, turbine oil, motor oil, alcohol, glycerine etc. Use of anything other than good quality hydraulic oil will void warranty and damage the pump, hose, and application. We recommend Durapac Hydraulic Oil or equivalent
- Equipment must only be serviced by a qualified hydraulic technician. For repair service, contact your local Durapac authorised service centre
- Tighten connections as needed. Use non-hardening pipe thread compound when servicing connections

Dirt, sand, etc. will quickly ruin any hydraulic system. Ensure that couplings are clean and free of foreign matter. After each use, clean couplings and attach dust caps.

Maintenance is required when wear or leakage is noticed. Periodically inspect all components to detect any problem that may require service and maintenance.

- 6.1 Check for loose connections and leaks.
- 6.2 Replace damaged parts immediately.
- 6.3 Do not exceed oil temperature above 60°C.
- 6.4 Keep all hydraulic components clean.
- 6.5 Use dust caps when puller is disconnected from the hose. Keep entire puller clean to prolong puller life.
- 6.6 Wipe thoroughly clean and store puller in the carry case (provided). Avoid temperature extremes.
- 6.7 Change hydraulic oil in your system as recommended in the pump instruction sheet.

7.0 Troubleshooting

Problem	Cause	Solution
Cylinder moves but does not maintain pressure	Leaking connection	<ul style="list-style-type: none"> • Clean, reseal with thread sealant and tighten connection
	Leaking cylinder seals	<ul style="list-style-type: none"> • Replace worn seals • Check for excessive contamination or wear • Replace contaminated fluid as necessary
	Malfunctioning pump/valve	<ul style="list-style-type: none"> • Repair or replace as necessary
Cylinder leaks hydraulic fluid	Worn or damaged seals	<ul style="list-style-type: none"> • Replace worn seals • Check for excessive contamination or wear • Replace contaminated fluid as necessary
	Loose connections	<ul style="list-style-type: none"> • Clean, reseal with thread sealant and tighten connection

Problem	Cause	Solution
Cylinder will not retract or retracts slower than normal	Closed pump release valve	<ul style="list-style-type: none"> Open pump release valve
	Loose couplers	<ul style="list-style-type: none"> Tighten couplers
	Blocked hydraulic lines	<ul style="list-style-type: none"> Clean and flush lines
	Weak or broken retraction springs	<ul style="list-style-type: none"> Send to a Durapac authorised service centre for repair
	Internally damaged cylinder	<ul style="list-style-type: none"> Send to a Durapac authorised service centre for repair
Erratic Action	Pump reservoir too full	<ul style="list-style-type: none"> Drain hydraulic fluid to correct level
	Air in system or pump cavitation	<ul style="list-style-type: none"> Add fluid, bleed air and check for leaks
	External leakage	<ul style="list-style-type: none"> Replace worn packings Check for excessive contamination fluid as necessary Replace contaminated fluid as necessary
Cylinder does not move	Sticking or binding cylinder	<ul style="list-style-type: none"> Check for dirt or leaks Check for bent, misaligned, worn parts or defective packings
	Loose couplers	<ul style="list-style-type: none"> Tighten couplers
	Faulty coupler	<ul style="list-style-type: none"> Verify that female coupler is not locked up (ball wedged into seat) Replace both male and female couplers
	Improper valve position	<ul style="list-style-type: none"> Close release valve or shift to new position
	Low or no hydraulic fluid in pump reservoir	<ul style="list-style-type: none"> Fill and bleed the system
	Air-locked pump	<ul style="list-style-type: none"> Add fluid, bleed air and check for leaks
Cylinder extends only partially	Load is above the capacity of the system	<ul style="list-style-type: none"> Use the correct equipment
	Low or no hydraulic fluid in pump reservoir	<ul style="list-style-type: none"> Fill and bleed the system
	Sticking or binding cylinder	<ul style="list-style-type: none"> Check for dirt or leaks Check for bent, misaligned, worn parts or defective packings
Cylinder moves slower than normal	Leaking cylinder seals	<ul style="list-style-type: none"> Replace worn seals Check for excessive contamination or wear Replace contaminated fluid as necessary
	Low fluid level in pump reservoir	<ul style="list-style-type: none"> Fill and bleed the system
	Restricted hydraulic line or fitting	<ul style="list-style-type: none"> Clean Replace if damaged
	Loose couplers	<ul style="list-style-type: none"> Tighten couplers

8.0 Parts Breakdown and List

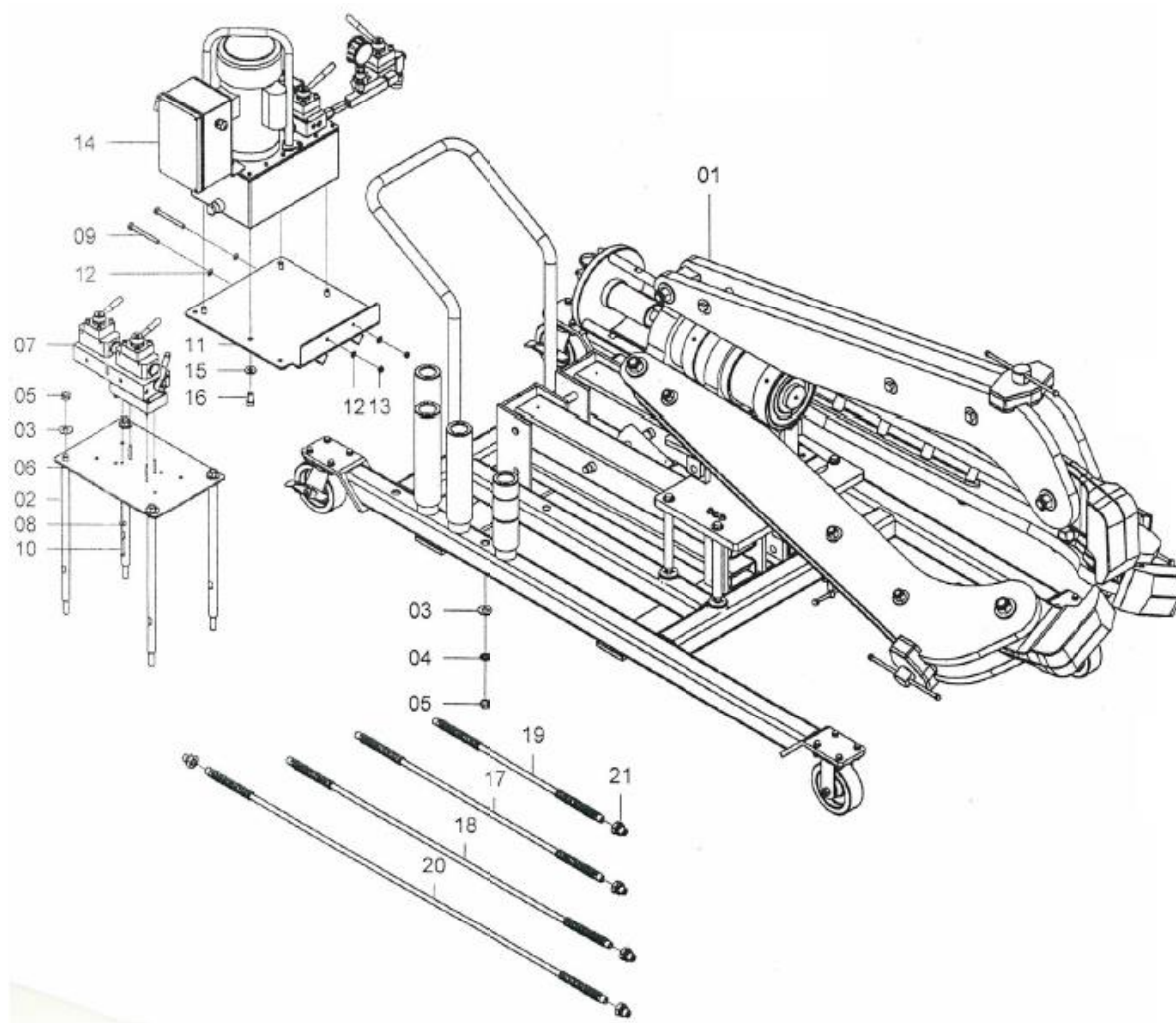

Item	Description	Part No.	Qty	Item	Description	Part No.	Qty
1	Puller & trolley	ZAL1693	1	11	Bracket	ZAL1762	1
2	Supports	ZAL1473	4	12	Washer	ZAL1763	4
3	Washer	ZAL1697	8	13	Nut	ZAL1484	2
4	Spring washer	ZAL1712	4	14	Electric power unit	PEM-1114-PL	1
5	Nut	ZAL1757	8	15	Washer	ZAL1764	4
6	Fixing for power unit	ZAL1758	1	16	Cap screw	ZAL1765	4
7	Control Panel	ZAL1759	1	17	Hose - 1 mtr	ZAL1766	2
8	Washer	ZAL1550	4	18	Hose - 1.2 mtr	ZAL1767	3
9	Screw	ZAL1760	2	19	Hose - 0.6 mtr	ZAL1768	1
10	Screw	ZAL1761	4	20	Hose - 1.5 mtr	ZAL1769	1
				21	Quick coupler	ZAL1065	8

* see following pages for further breakdown

8.1 ZAL1693 - Puller and Trolley Assembly

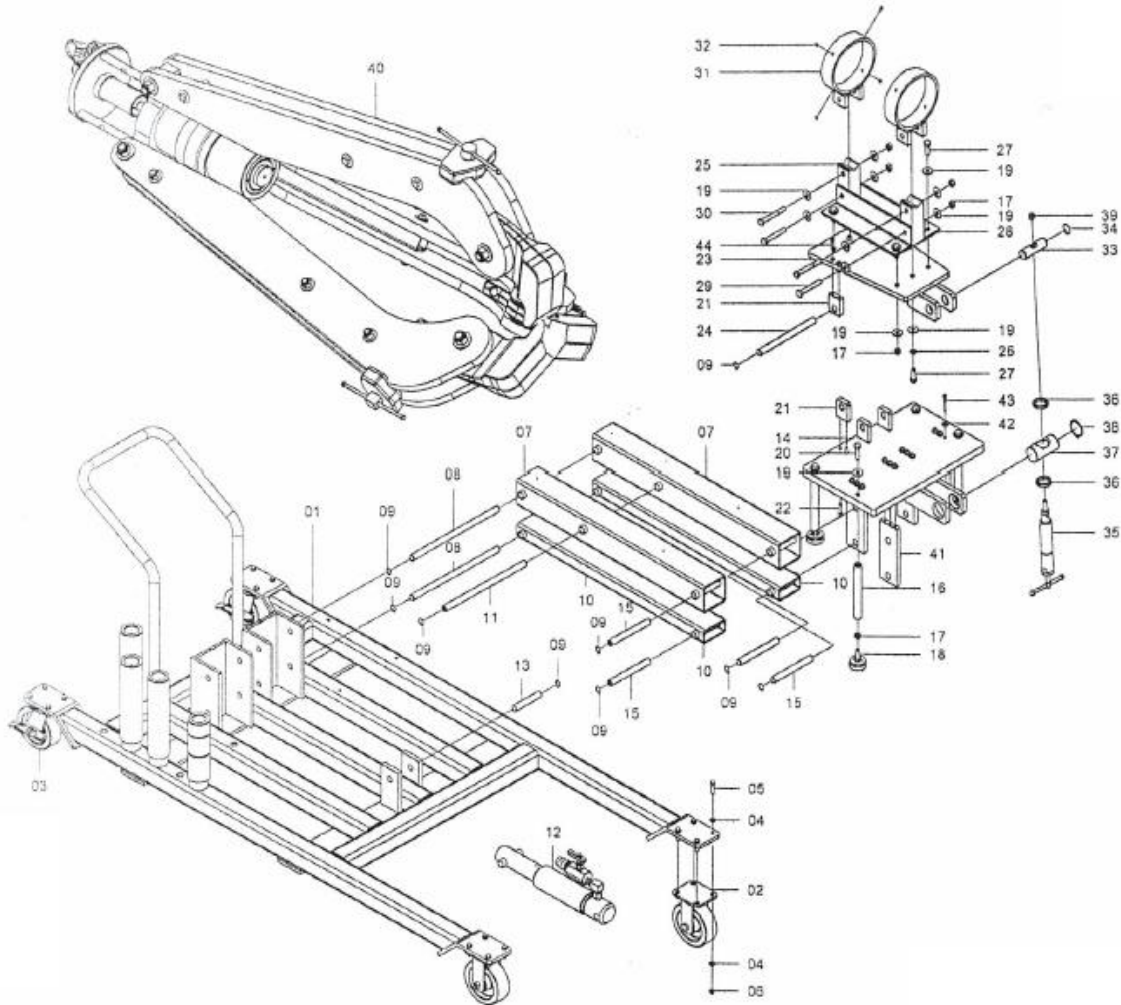

Item	Description	Part No.	Qty	Item	Description	Part No.	Qty
1	Trolley	ZAL1771	1	23	Saddle plate	ZAL1790	1
2	6" wheel	ZAL1772	2	24	Pin	ZAL1791	1
3	6" locking wheel	ZAL1773	2	25	Ring support	ZAL1792	2
4	Washer	ZAL1763	32	26	Spring washer	ZAL1793	2
5	Screw	ZAL1774	16	27	Screw	ZAL1794	6
6	Nut	ZAL1484	16	28	L shape fitting	ZAL1795	2
7	Elevator arm A	ZAL1775	2	29	Screw	ZAL1796	2
8	Pin	ZAL1776	2	30	Screw	ZAL1797	2
9	Retaining ring	ZAL1777	18	31	Cylinder fixing ring	ZAL1798	2
10	Elevator arm B	ZAL1778	2	32	Screw	ZAL1284	8
11	Pin	ZAL1779	1	33	Saddle plate trunnion	ZAL1799	1
12	Lifting cylinder	ZAL1780	1	34	Retaining ring	ZAL1328	2
13	Pin	ZAL1781	1	35	Grease type pump	ZAL1800	1
14	Saddle base	ZAL1782	1	36	Fixing ring	ZAL1801	2
15	Pin	ZAL1783	4	37	Saddle base trunnion	ZAL1802	1
16	Adjustable screw arm	ZAL1784	4	38	Retaining ring	ZAL1803	2
17	Nut	ZAL1785	12	39	Hex nut	ZAL1804	1
18	Adjustable screw arm	ZAL1786	4	40	100 ton puller	ZAL1805	1
19	Washer	ZAL1764	22	41	Saddle base foot	ZAL1806	4
20	Screw	ZAL1787	4	42	Washer	ZAL1807	12
21	Angle fixing block	ZAL1788	5	43	Screw	ZAL1808	12
22	Screw	ZAL1789	6	44	Screw	ZAL1809	4

8.1.1 ZAL1780 – Lifting Cylinder Assembly

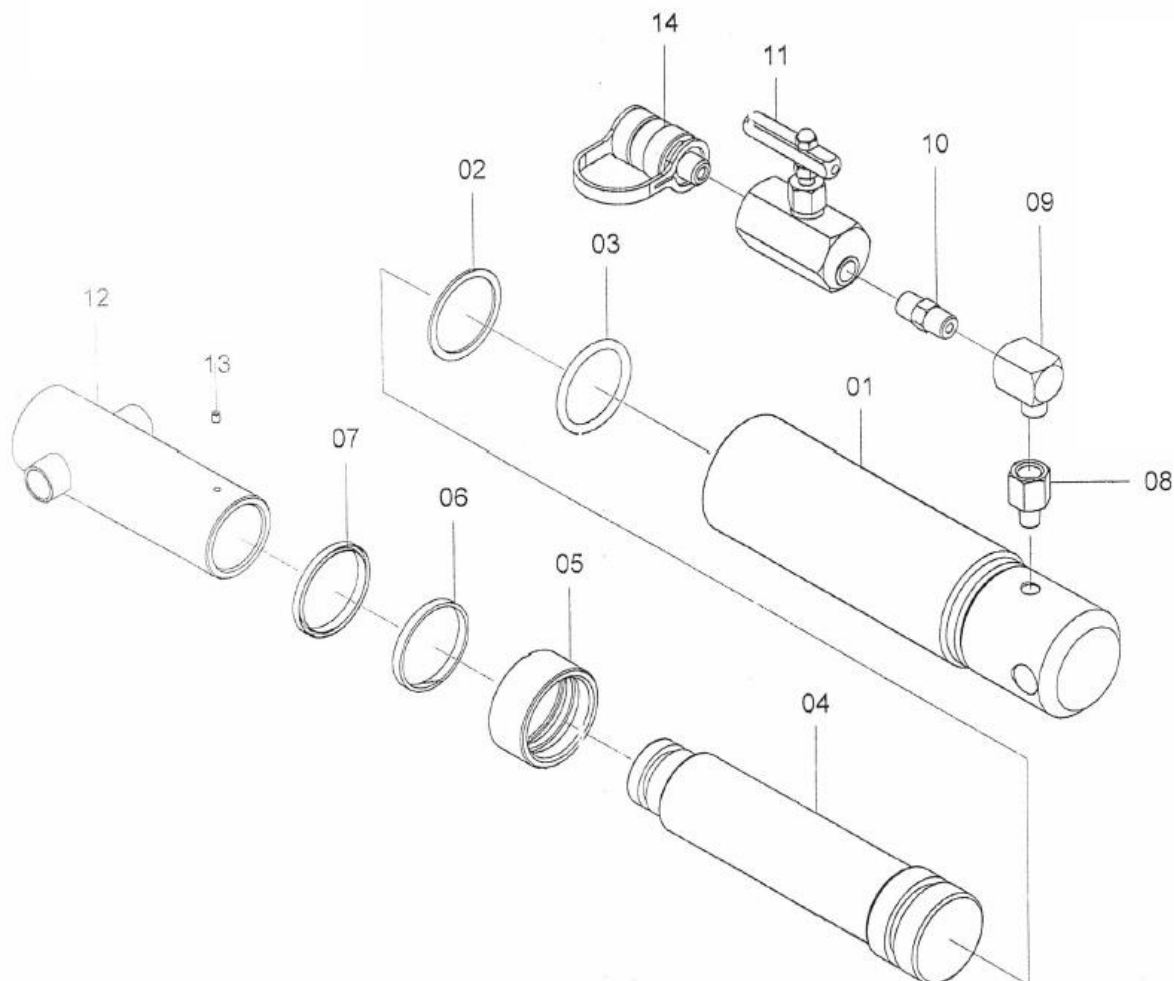

Item	Description	Part No.	Qty	Item	Description	Part No.	Qty
1	Cylinder base	ZAL1906	1	8	Adaptor	ZAL1905	1
2	Back-up ring	ZAL1907	1	9	Elbow	ZAL1913	1
3	O-ring	ZAL1908	1	10	Hexagon nipple	ZAL1914	1
4	Piston rod	ZAL1909	1	11	Needle valve	ZAL1915	1
5	Fasten nut	ZAL1910	1	12	Connection tube	ZAL1916	1
6	Split ring	ZAL1911	1	13	Screw	ZAL1289	1
7	Wiper	ZAL1912	1	14	Quick coupler	ZAL1917	1

8.1.2 ZAL1800 – Grease Type Pump Assembly

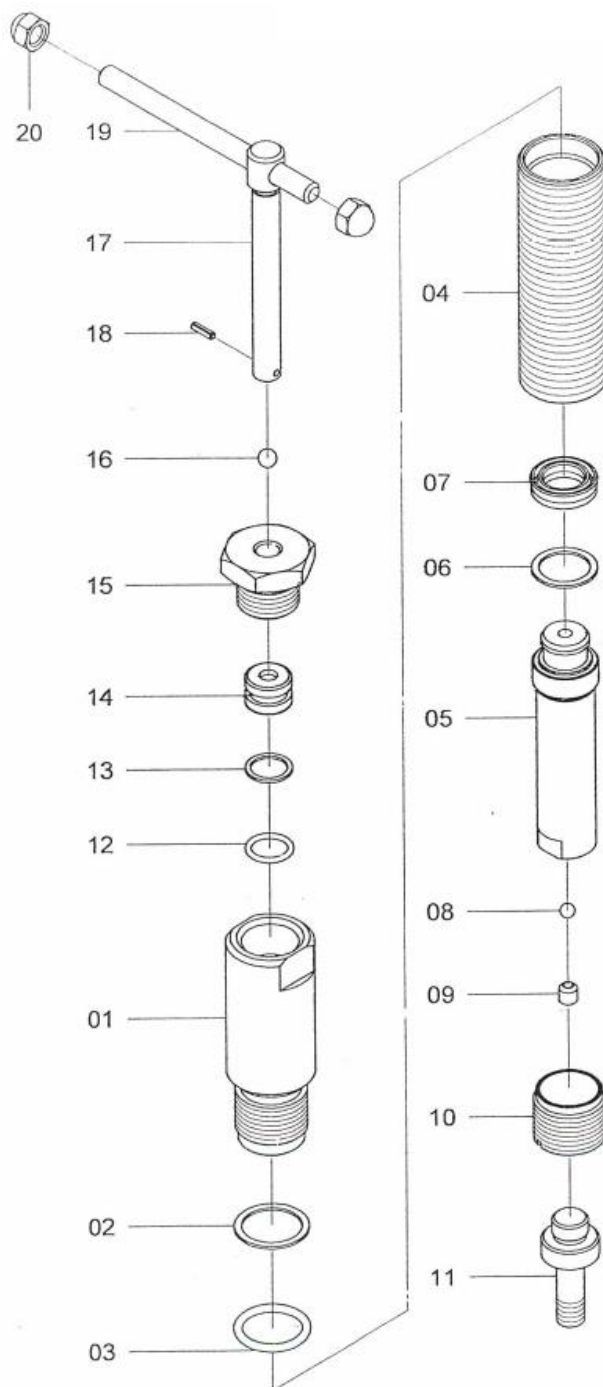

Item	Description	Part No.	Qty	Item	Description	Part No.	Qty
1	Cylinder upper seat	ZAL1918	1	11	Piston rod connector	ZAL1924	1
2	Back-up ring	ZAL1919	1	12	O-ring	ZAL1925	1
3	O-ring	ZAL1920	1	13	Back-up ring	ZAL1900	1
4	Cylinder base	ZAL1921	1	14	Pump piston	ZAL1926	1
5	Piston rod	ZAL1922	1	15	Driving rod seat	ZAL1927	1
6	Back-up ring	ZAL1635	1	16	Steel ball	ZAL1368	1
7	U-cup seal	ZAL1636	1	17	Driving rod	ZAL1928	1
8	Steel ball	ZAL1366	1	18	Spring pin	ZAL1929	1
9	Screw	ZAL1284	1	19	Handle rod	ZAL1930	1
10	Fasten nut	ZAL1923	1	20	Nut	ZAL1413	2

8.1.3 ZAL1805 – 100 Ton Puller Assembly

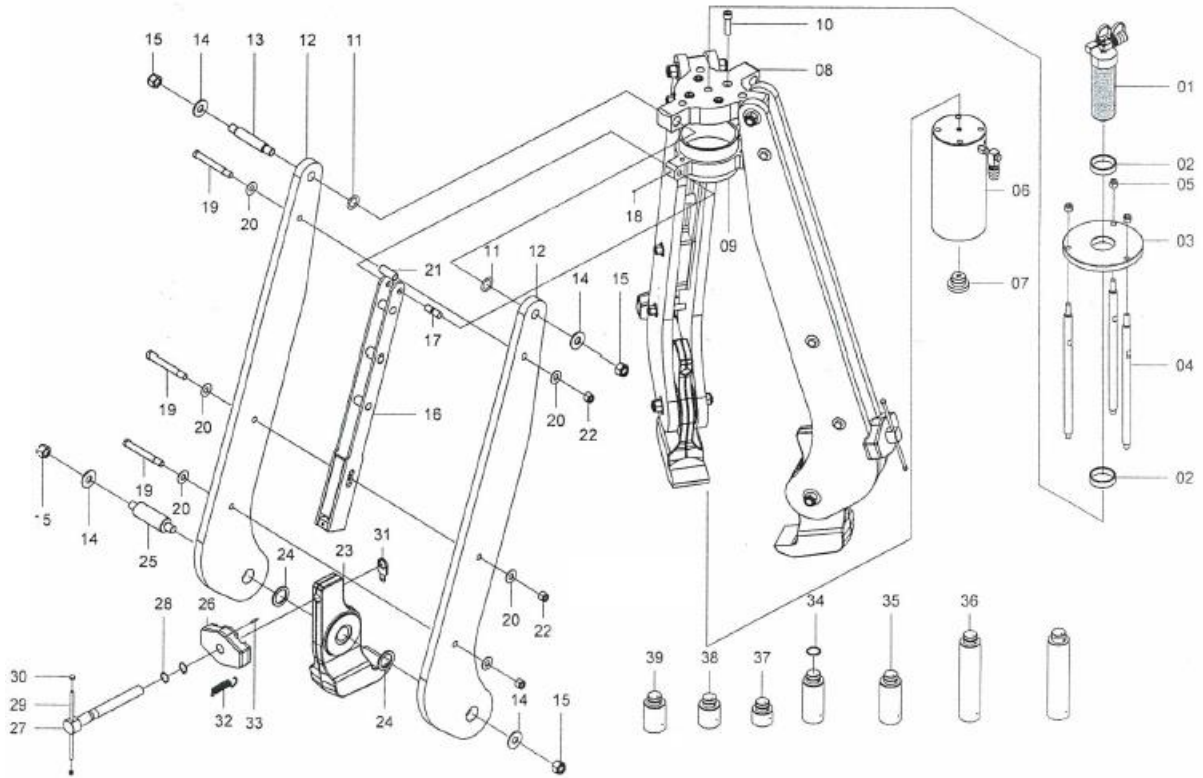

Item	Description	Part No.	Qty	Item	Description	Part No.	Qty
1	Double acting cylinder	ZAL1810	1	21	Bushing	ZAL1829	3
2	Fixed ring	ZAL11811	2	22	Anti-loosen nut	ZAL1830	9
3	Fixed plate	ZAL11812	1	23	Jaw head	ZAL1831	3
4	Support shaft	ZAL11813	3	24	Bushing	ZAL1832	6
5	Anti-loosen nut	ZAL1298	3	25	Jaw head screw	ZAL1833	3
6	Single acting spring return cyl.	ZAL1814	1	26	Adjusting block	ZAL1834	3
7	Removable cone assembly	ZAL1815	1	27	Driving screw	ZAL1835	3
8	2/3-way puller crosshead	ZAL1816	1	28	Retaining ring	ZAL1836	6
9	2/3-way sliding socket	ZAL1817	1	29	Handle rod	ZAL1837	3
10	Cap screw	ZAL1818	4	30	Nut	ZAL1413	6
11	Washer	ZAL1819	6	31	Jaw head spring plate	ZAL1838	3
12	Puller jaw	ZAL1820	6	32	Jaw head spring	ZAL1839	3
13	Jaw screw	ZAL1821	3	33	Spring pin	ZAL1840	3
14	Washer	ZAL1822	12	34	O-ring	ZAL1618	7
15	Anti-loosen nut	ZAL1823	12	35	Extension bar A	ZAL1841	2
16	Puller jaw strap	ZAL1824	3	36	Extension bar B	ZAL1842	2
17	Pin	ZAL1825	3	37	Extension bar C	ZAL1843	1
18	Screw	ZAL1826	3	38	Extension bar D	ZAL1844	1
19	Screw	ZAL1827	9	39	Extension bar E	ZAL1845	1
20	Washer	ZAL1828	18				

8.1.3.1 ZAL1810 – Double Acting Cylinder

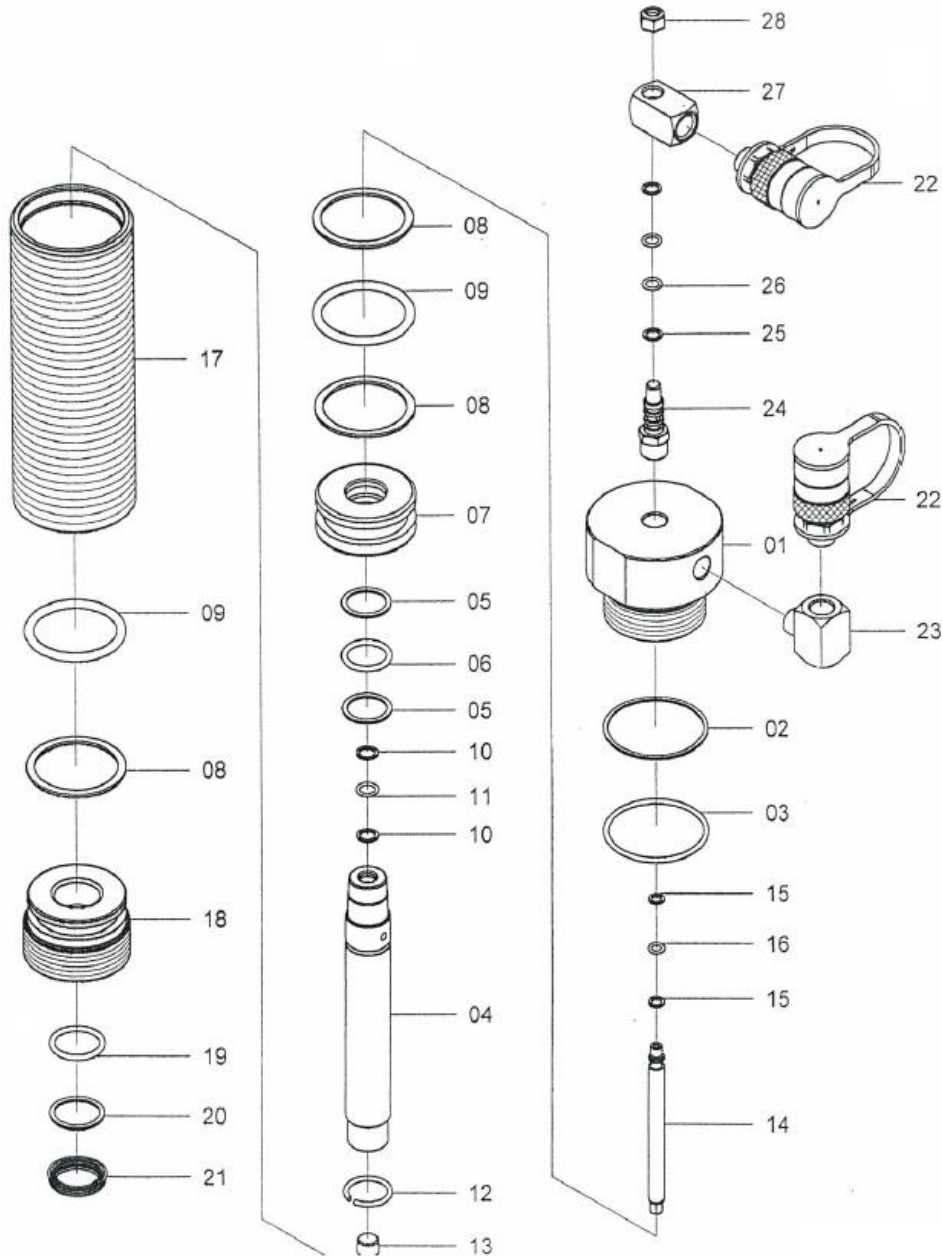

Item	Description	Part No.	Qty	Item	Description	Part No.	Qty
1	Cylinder base	ZAL1931	1	15	Back-up ring	ZAL1521	2
2	Back-up ring	ZAL1932	1	16	O-ring	ZAL1522	1
3	O-ring	ZAL1933	1	17	Cylinder base	ZAL1935	1
4	Piston rod	ZAL1511	1	18	Fasten nut	ZAL1936	1
5	Back-up ring	ZAL1512	2	19	O-ring	ZAL1277	1
6	O-ring	ZAL1513	1	20	Back-up ring	ZAL1225	1
7	Brass bushing	ZAL1934	1	21	Wiper	ZAL1214	1
8	Back-up ring	ZAL1907	3	22	Quick coupler	ZAL1917	2
9	O-ring	ZAL1908	2	23	Elbow	ZAL1913	1
10	Back-up ring	ZAL1515	2	24	Oil pressure valve ass'y	ZAL1565	1
11	O-ring	ZAL1516	1	25	Back-up ring	ZAL1218	2
12	Spring ring	ZAL1519	1	26	O-ring	ZAL1274	2
13	Screw	ZAL1297	1	27	Coupler body	ZAL1566	1
14	Main piston	ZAL1520	1	28	Anti-loosen nut	ZAL1567	1

8.1.3.2 ZAL1814 – Single Acting Spring Return Cylinder

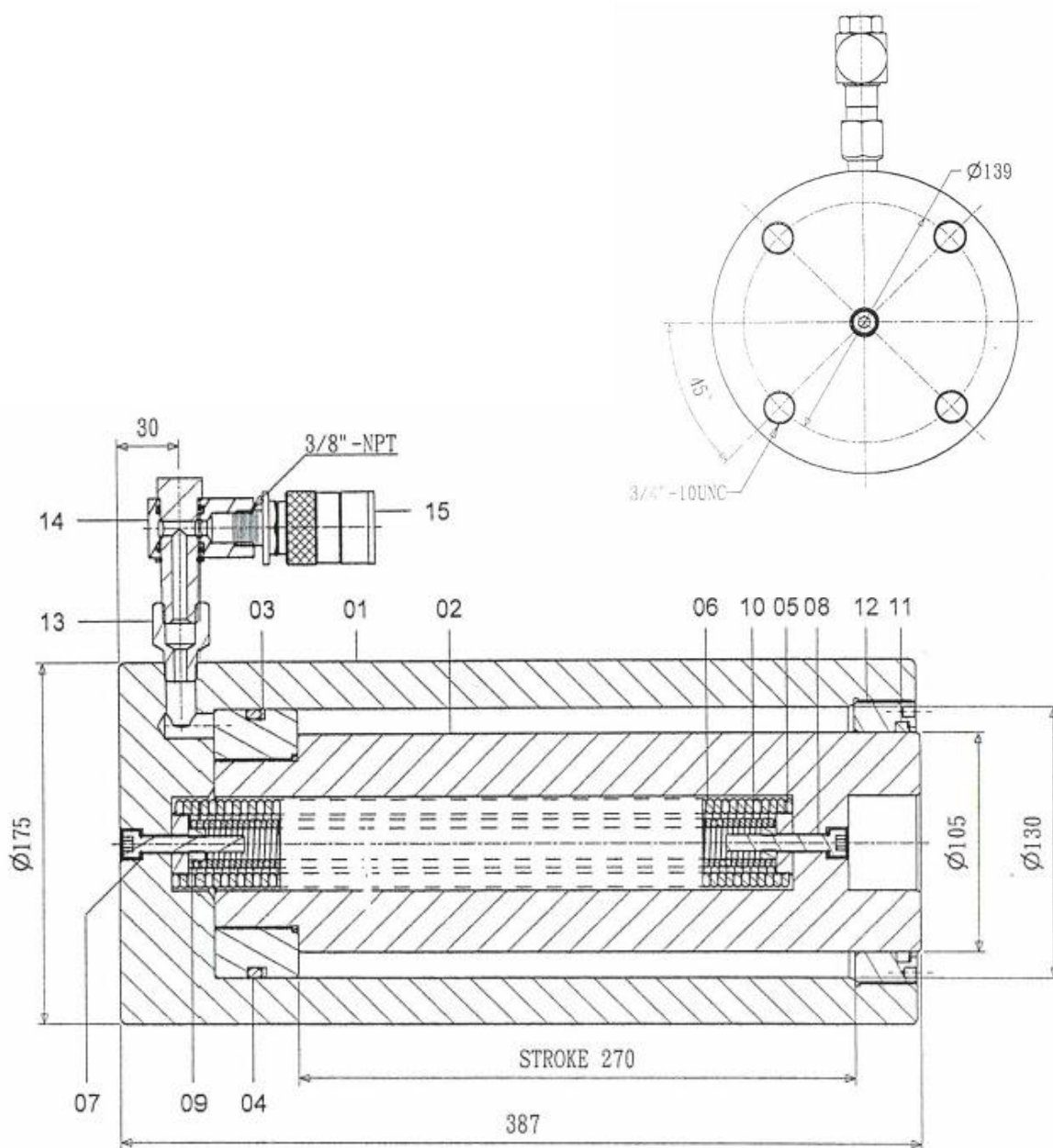

Item	Description	Part No.	Qty	Item	Description	Part No.	Qty
1	Cylinder base	ZAL1937	1	8	Screw	ZAL1808	2
2	Piston rod	ZAL1938	1	9	Spring lock	ZAL1944	2
3	Back-up ring	ZAL1939	1	10	Spring	ZAL1945	1
4	O-ring	ZAL1940	1	11	Wiper	ZAL1946	1
5	Spring lock	ZAL1941	2	12	Fasten nut	ZAL1947	1
6	Spring	ZAL1942	1	13	Adaptor	ZAL1948	1
7	Gasket seal	ZAL1943	2	14	High flow swivel connector	ZAL1949	1
				15	Quick coupler	ZAL1917	1

8.2 ZAL1759 – Control Panel Assembly

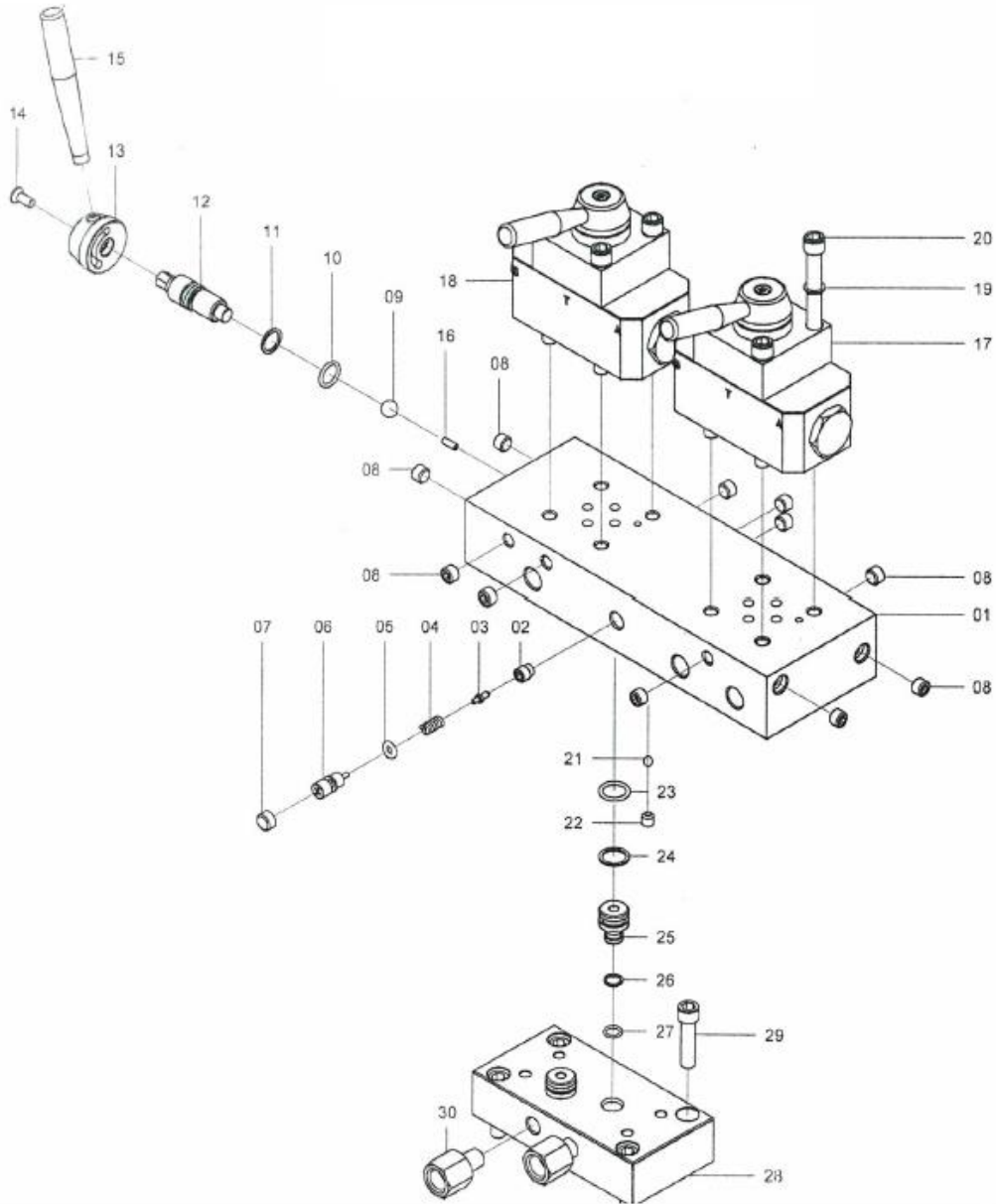

Item	Description	Part No.	Qty	Item	Description	Part No.	Qty
1	Connecting block	ZAL1891	1	16	Spring pin	ZAL1896	1
2	Cone seat	ZAL1153	1	17	Directional control valve	ZAL1897	1
3	Cone	ZAL1152	1	18	Directional control valve	ZAL1898	1
4	High pressure spring	ZAL1361	1	19	Copper washer	ZAL1357	8
5	O-ring	ZAL1210	1	20	Screw	ZAL1899	8
6	Overload cover screw	ZAL1315	1	21	Steel ball	ZAL1366	1
7	Cap	ZAL1041	1	22	Screw	ZAL1284	1
8	Screw	ZAL1303	11	23	O-ring	ZAL1229	2
9	Steel ball	ZAL1892	1	24	Back-up ring	ZAL1900	2
10	O-ring	ZAL1233	1	25	Link tube	ZAL1901	2
11	Back-up ring	ZAL1893	1	26	Back-up ring	ZAL1902	2
12	Release valve screw	ZAL1894	1	27	O-ring	ZAL1251	2
13	Switch base	ZAL1895	1	28	Valve body	ZAL1903	1
14	Screw	ZAL1319	1	29	Cap screw	ZAL1904	4
15	Handle	ZAL1160	1	30	Adaptor	ZAL1905	2

8.3 PEM-1114-PL –Electric Power Unit

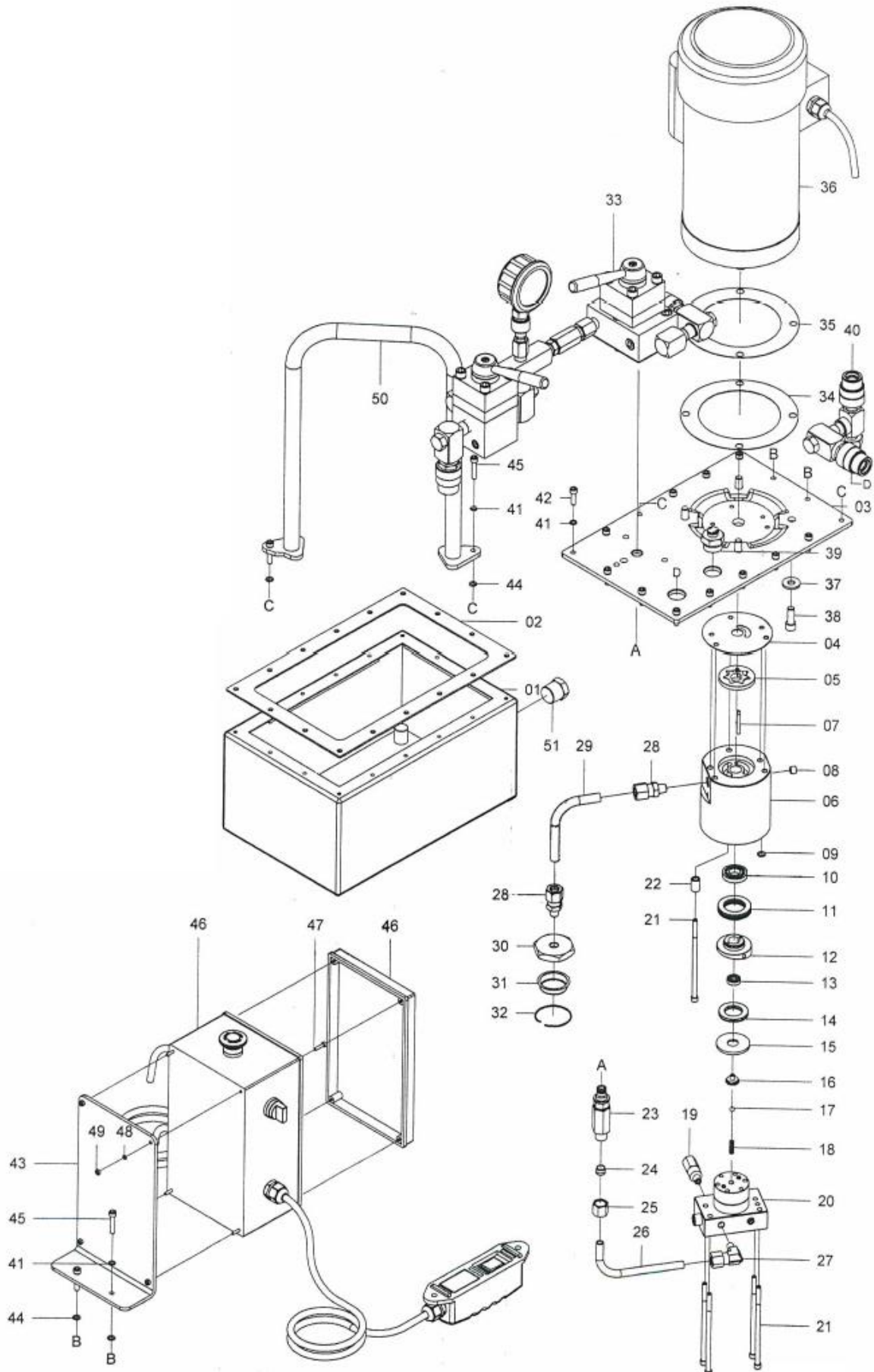

8.3.1 PEM-1114-PL –Electric Power Unit (Parts Listing)

Item	Description	Part No.	Qty	Item	Description	Part No.	Qty
1	Reservoir	ZAL1846	1	27	Male elbow	ZAL1869	1
2	Reservoir gasket	ZAL1847	1	28	Male connector	ZAL1870	2
3	Reservoir cover	ZAL1848	1	29	Intake tube	ZAL1871	1
4	Wear plate	ZAL1849	1	30	Filter nut	ZAL1872	1
5	Gerotor set	ZAL1850	1	31	Filter	ZAL1873	1
6	Pump body	ZAL1851	1	32	Spring ring	ZAL1874	1
7	Link bolt	ZAL1852	1	33	Valve assembly	ZAL1875	1
8	Pipe plug	ZAL1853	1	34	Aluminium washer	ZAL1876	1
9	O-ring	ZAL1273	1	35	Motor seal	ZAL1877	1
10	Ball bearing	ZAL1854	1	36	Electric motor	ZAL1878	1
11	Fixing bearing	ZAL1855	1	37	Washer	ZAL1879	4
12	Angle plate	ZAL1856	1	38	Cap screw	ZAL1880	4
13	Ball bearing	ZAL1857	1	39	Breather assembly	ZAL1881	1
14	Bearing	ZAL1858	1	40	Coupler assembly	ZAL1882	1
15	Top plate	ZAL1859	1	41	Washer	ZAL1883	16
16	Top plate bearing	ZAL1860	1	42	Screw	ZAL1884	12
17	Steel ball	ZAL1366	1	43	Fixed plate	ZAL1885	1
18	Spring	ZAL1745	1	44	O-ring	ZAL1522	4
19	Relief valve assembly	ZAL1861	1	45	Screw	ZAL1886	4
20	High pressure pump ass'y	ZAL1862	1	46	Electric plate box	ZAL1887	1
21	Cap screw	ZAL1863	5	47	Cap screw	ZAL1888	4
22	Spacer	ZAL1864	1	48	Spring washer	ZAL1533	4
23	Valve connector	ZAL1865	1	49	Nut	ZAL1320	4
24	Ferrule sleeve	ZAL1866	1	50	Handle	ZAL1889	1
25	Nut	ZAL1867	1	51	Set screw	ZAL1890	1
26	Oil line tube	ZAL1868	1				

9.0 Hydraulic System Connection

