

DURAPAC
ENGINEERED FOR RELIABILITY

Instruction Manual

50 Ton Hydraulic Puller
Model – DHP-50E



Maximum Operating Pressure – 700 bar



This is a safety alert symbol. It is used to alert you to potential personal injury hazards. Obey all safety messages that follow this symbol to avoid injury or death

1.0 Product Information

DURAPAC – Hydraulic Pullers are engineered to meet Industrial Standards for Performance and Safety. The DHP-50E model uses a double acting hydraulic system for holding, opening & closing jaws; providing a safe and secure grip at all times. They also feature the following:

- Flow metering system provides constant lowering speed
- Single acting, spring return, 50 ton capacity cylinder
- Easy jaw head adjusting system prevents puller jaws from sliding
- Puller can be assembled in 2 or 3 jaw configuration
- Puller can be adjusted 5 degrees up or down of puller centreline for precise positioning
- Castors provide easy cart movement
- Includes electric power unit with 230V single phase or 380V three phase options
- Includes four extensions

Special skill, knowledge and training may be required for a specific task and the product may not be suitable for all jobs. The user must ultimately make the decision regarding suitability of the product for any given task and assume the responsibility of safety for all in the work area. Contact a Durapac representative if you are unsure of your puller's suitability for a particular application.

2.0 Receiving Instructions

It is recommended prior to use that an inspection be done by qualified personnel and that any missing or damaged parts, decals, warning/safety labels or signs are replaced with Durapac authorised replacement parts only. Any puller that appears to be damaged in any way, is worn, leaking or operates abnormally should be removed from service immediately until such time as repairs can be made. Any puller that has been or suspected to have been subject to a shock load should be removed from service immediately until inspected by a Durapac authorised service centre.

Owners and operators of this equipment should be aware that the use and subsequent repair of this equipment may require specialised training and knowledge.

3.0 Safety

Save these instructions. For your safety, read and understand the information contained within. The owner and operator should have an understanding of this product and safe operating procedures before attempting to use this product. Instructions and safety information should be conveyed in the operator's native language before use of this product is authorised. Make certain that the operator thoroughly understands the inherent dangers associated with the use and misuse of the product. If any doubt exists as to the safe and proper use of this product as outlined in this factory authorised manual, remove from service immediately.



DANGER:

- To avoid personal injury keep hands and feet away from work area during operation

- **Do NOT** handle pressurised hoses. Escaping oil under pressure can penetrate the skin causing serious injury. If oil is injected under the skin, see a doctor immediately
- Stay clear of loads supported by hydraulics. A cylinder, when used as a load lifting device, should never be used as a load holding device. After the load has been raised or lowered, it must always be supported mechanically

**WARNING:**

- The system operating pressure must not exceed the pressure rating of the lowest rated component in the system. Install pressure gauges in the system to monitor operating pressure. It is your window to what is happening in the system
- Always wear appropriate personal protective equipment (PPE) when operating hydraulic equipment. The operator must take precaution against injury due to failure of the tool or work piece(s)
- **Do NOT** hold or stand directly in line with any hydraulic connections while pressurising
- **Do NOT** attempt to disconnect hydraulic connections under pressure. Release all line pressure before disconnecting hoses
- All personnel must be clear before lowering load or depressurising the system
- **Do NOT** attempt to lift a load weighing more than the capacity of the cylinder

**IMPORTANT:**

- If at any stage, the safety related decals become hard to read, these must be replaced
- Minimum age of the operator must be 18 years. The operator must have read and understood all instructions, safety issues, cautions and warnings before starting to operate the equipment. The operator is responsible for this activity towards other persons
- **Do NOT** lift hydraulic equipment by the hoses or couplers. Use the carrying handle or other means of safe transport
- Hydraulic equipment must only be serviced by a qualified hydraulic technician. For repair service, contact the Durapac authorised service centre in your area. To protect your warranty, use only high quality hydraulic oil

**CAUTION:**

- **KEEP HYDRAULIC EQUIPMENT AWAY FROM FLAMES AND HEAT.** Hydraulic fluid can ignite and burn. Excessive heat will soften packings and seals, resulting in fluid leaks. Heat also weakens hose materials and packings. For optimum performance do not expose equipment to temperatures of 65°C (150°F) or higher. Protect all equipment from weld spatter
- No alteration should be made to this device

3.1 Hydraulic Pullers

- Align the puller jaw and pushing adaptor set-ups on the same centreline as the parts being removed. Failure to align parts correctly can result in a dangerous operating situation because of the high hydraulic pressure used

- Before applying pressure, wrap the work in a safety blanket/ sheath to protect from injury caused by flying parts should a part ever break
- Stand behind or to the side of the puller when applying pressure
- **Do NOT** heat the part to be removed. When the puller comes in contact with the part, heating can result in damage to components of the puller
- Always support the object being pulled
- Apply force gradually
- Ensure that the puller jaws are fully engaged with the workpiece being pulled
- **Do NOT** overload equipment. Overloading can cause equipment failure and possible personal injury. **Do** use a gauge or other load measuring instrument to verify load
- **Do NOT** over extend the puller
- Only operate within the limits of the pullers' rated stroke. Do not try to pull objects that are beyond 101.6 mm in the thickness at the maximum opening of 1,250 mm or require the jaws to be opened to more than 1,250 mm
- **Never** pressurise uncoupled couplers. Only use hydraulic equipment in a coupled system
- Use only Durapac approved accessories and components

3.2 Hydraulic Hoses & Fluid Transmission Lines

- Avoid short runs of straight line tubing. Straight line runs do not provide for expansion and contraction due to pressure and/or temperature changes
- Reduce stress in tube lines. Long tubing runs should be supported by brackets or clips. Before operating the pump, connections should be tightened securely and leak-free. Over tightening can cause premature thread failure or high pressure fittings to burst
- Should a hydraulic hose ever rupture, burst or need to be disconnected, immediately shut off the pump and release all pressure. Never attempt to grasp a leaking pressurised hose with your hands. The force of escaping hydraulic fluid can inflict injury
- **Do NOT** subject the hose to potential hazard such as fire, sharp objects, extreme heat or cold or heavy impact
- **Do NOT** allow the hose to kink, twist, curl, crush, cut or bend so tightly that the fluid flow within the hose is blocked or reduced. Periodically inspect the hose for wear
- Hose material and coupler seals must be compatible with the hydraulic fluid used. Hoses also must not come in contact with corrosive materials such as battery acid, creosote-impregnated objects and wet paint. Never paint a coupler or hose

FAILURE TO HEED THESE WARNINGS MAY RESULT IN PERSONAL INJURY AS WELL AS PROPERTY DAMAGE.

4.0 Installation

⚠ IMPORTANT: Always secure threaded port connections with high grade, non-hardening pipe thread sealant. Teflon tape can be used if only one layer of tape is used and it is applied carefully, two threads back, to prevent the tape from being introduced into hydraulic system, which could cause jamming of precision-fit parts

- 4.1 Familiarise yourself with the specifications and illustrations in this owner’s manual. Know your puller, its limitations and how it operates before attempting to use. Refer to the specification chart below or if in doubt, contact a Durapac representative.

Model Number	Stroke (mm)	Pull Capacity (ton)	Max. Spread (mm)	Reach at Min. Spread (mm)	Weight (kg)
DHP-50E	330	50	1,250	900	391

- 4.2 Make hydraulic connections.

⚠ IMPORTANT: Fully hand-tighten all couplers. Loose coupler connections will block the flow of oil between the pump and the puller

- 4.3 Check all system fittings and connections to be sure they are tight and leak free.
- 4.4 Check oil level in reservoir before operating pump.
- 4.5 Remove air from the system – Position the puller so that the piston rod is pointed down and the cylinder is lower than the pump. Advance and retract the cylinder several times, avoiding pressure build-up. Air removal is complete when the cylinder motion is smooth.

5.0 Operation

Note - This puller has a 2/3-way combination puller head. The 3-way combination is strongly recommended whenever the job space allows as three jaws give a more secure grip and more even pulling force.

5.1 Setting up the Puller

- 5.1.1 Select the proper size and capacity of the puller needed for the job. This is determined by measuring the ‘reach’ and the ‘spread’ of the part to be pulled. Refer to the table in 4.1.
- 5.1.2 Connect the electric hydraulic pump to a suitable 230 Volt 10-amp power outlet. Ensure the flow control valves are in the original locked position. These flow control valves will ensure a steady raising and lowering of the trolley.
- 5.1.3 The centreline of the workpiece being pulled must be on the same centreline as the puller head.

5.2 Adjusting Trolley Height/Puller Alignment

5.2.1 Align the puller horizontally and vertically as close as possible to the same centreline as the object to be pulled (see Figure 1).

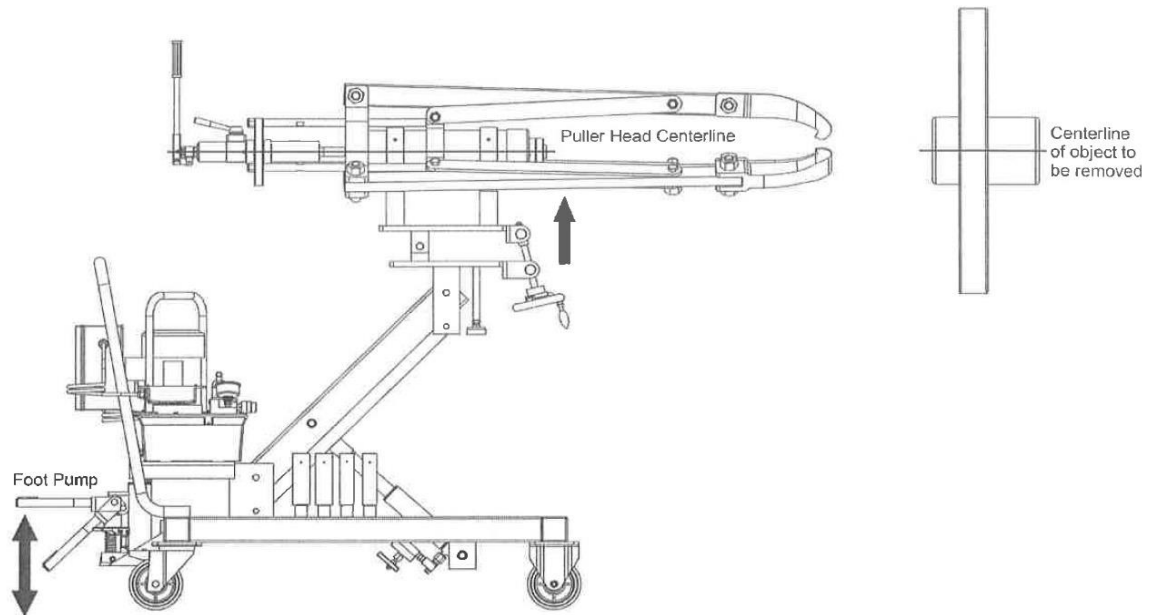

Figure 1 – Puller Alignment

5.3 Adjusting Puller Arms

5.3.1 Rotate the control valve on the pump in a clockwise direction and pump the handle to open the jaws enough to fit over the work (see Figure 2).

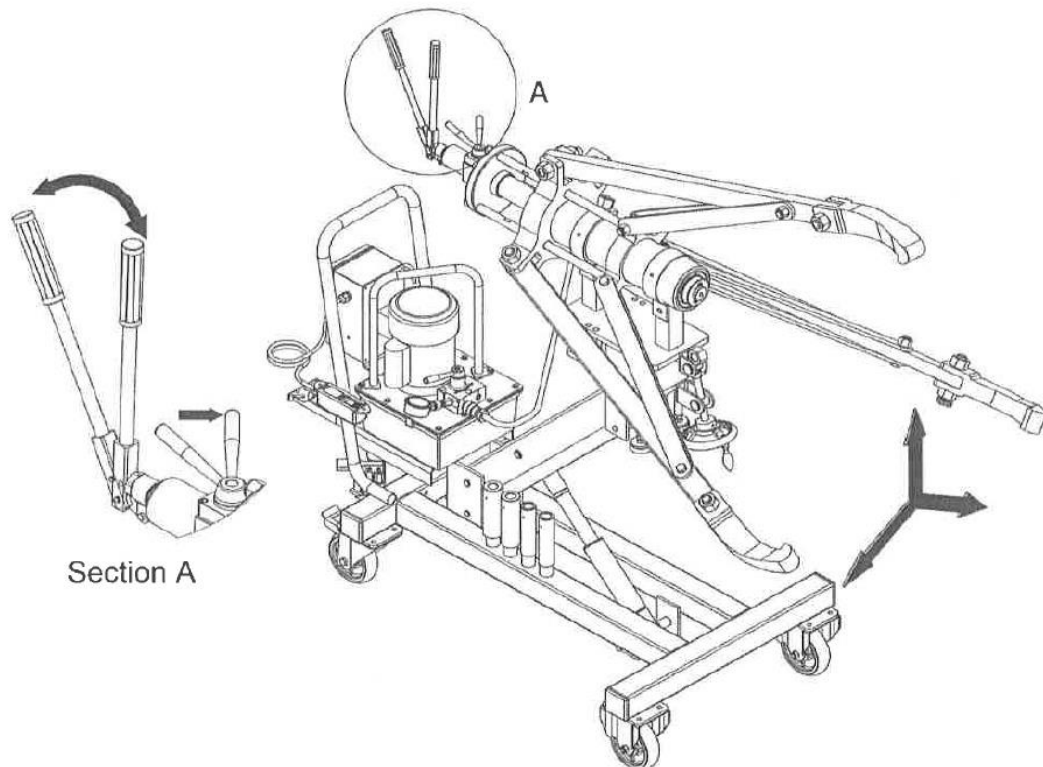

Figure 2 – Adjusting the Puller Arms

- 5.3.2 To ensure the puller head is on the same centreline as the object to be pulled, rotate the round handle under the puller clockwise to angle the puller head down; and in a counter clockwise direction to angle the puller head up (see Figure 3).

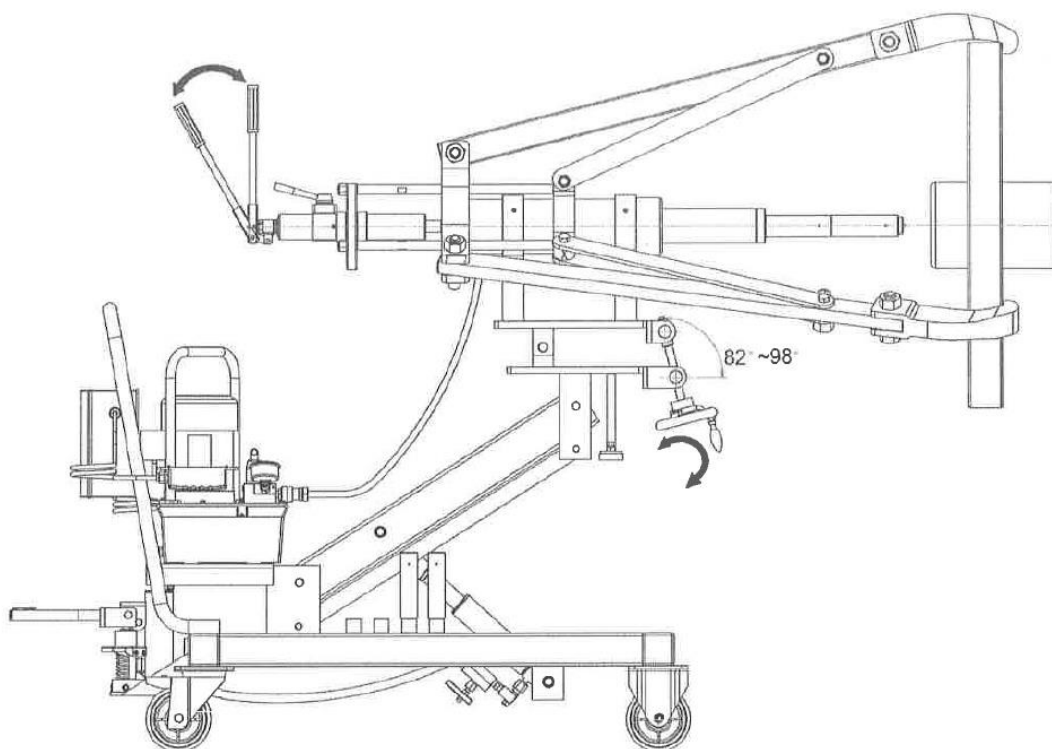

Figure 3 – Adjusting the Puller Head

- 5.3.3 Rotate the control valve on the pump in a counter clockwise direction and pump the handle to close the jaws tightly around the part to be pulled (see Figure 4-1). Ensure the jaws are fully engaged and secure (see Figure 4-2).

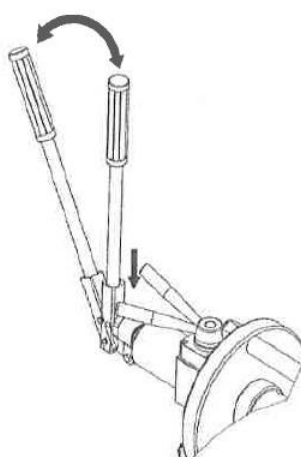

Figure 4-1 – Closing the Puller Jaws

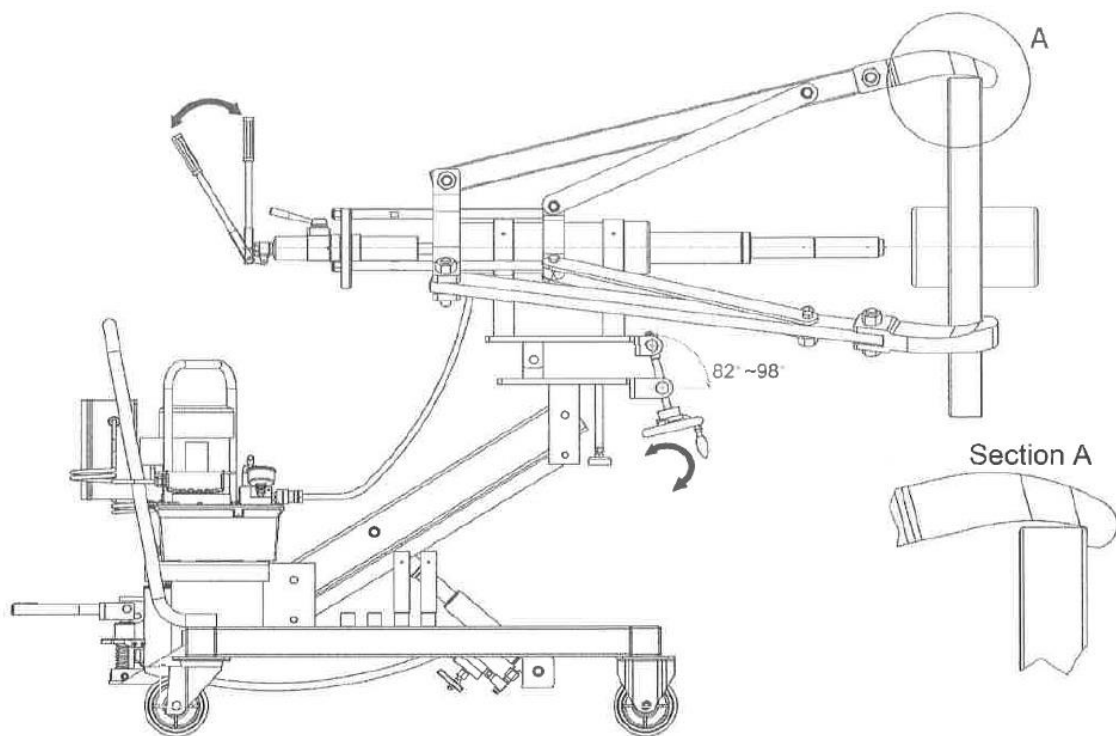

Figure 4-2 – Fully Engaged Jaws

5.3.4 Add as many adaptors as practical to the forcing cylinder (see Figure 5).

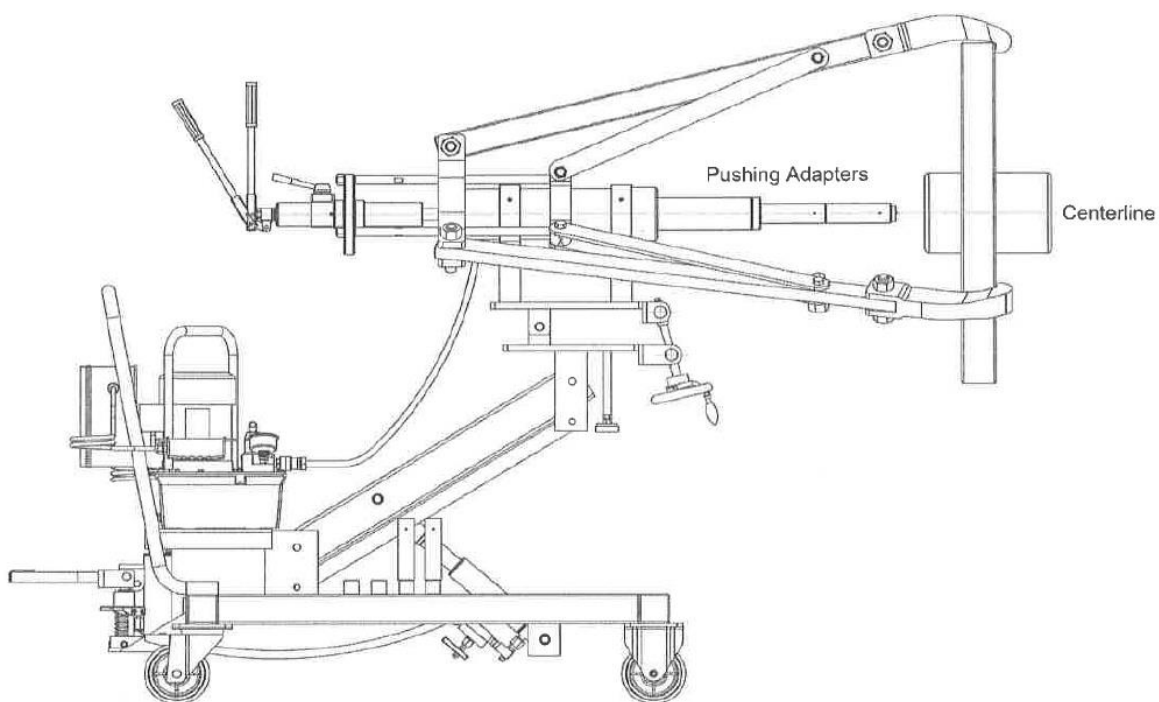

Figure 5 – Adding Adaptors

- 5.3.5 Once the puller is aligned, press the button on the remote switch to advance the forcing cylinder toward the object, stopping just as the cylinder head touches the shaft (see Figure 6).

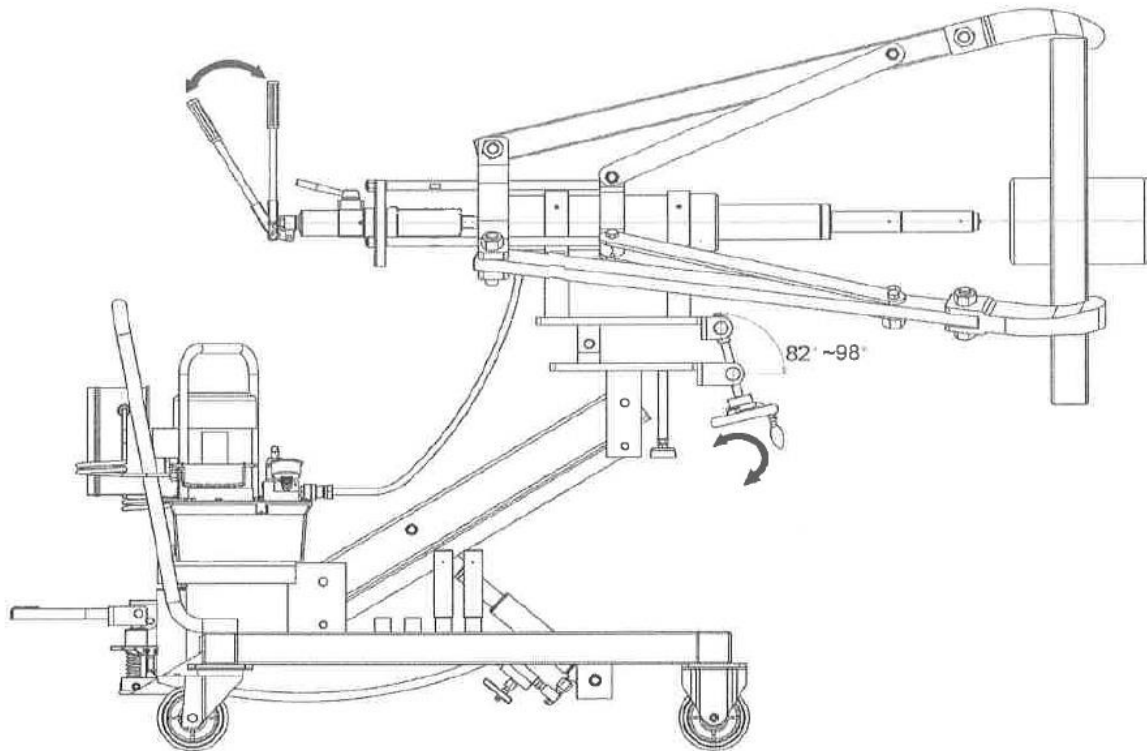

Figure 6 – Advancing the Forcing Cylinder

- 5.3.6 At the point that the cylinder head contacts the shaft, release the button and inspect the puller and workpiece for proper alignment.
- 5.3.7 Wrap the work with a protective blanket and ensure a support is attached to the work that is to be pulled.

5.4 Operating the Puller

- 5.4.1 Stand behind and to one side of the puller. Continue with pulling job by pressing the button on the remote switch (see Figure 7).

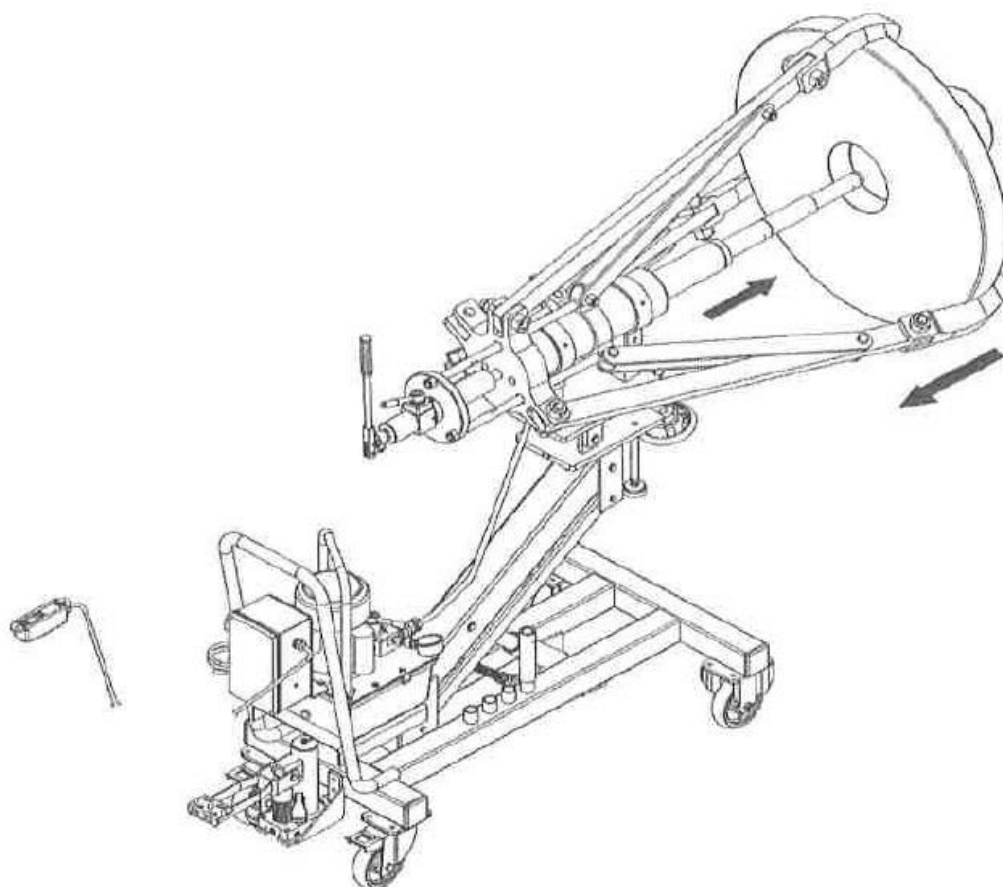

Figure 7 – Operating the Puller

- 5.4.2 If the full stroke has been reached but the object has not been pulled completely, retract the cylinder to allow the addition of another adaptor while maintaining the gripping action of the jaws on the object.

5.4.3 Rotate the control valve on the pump in a counter clockwise direction to open the jaws (see Figure 8).

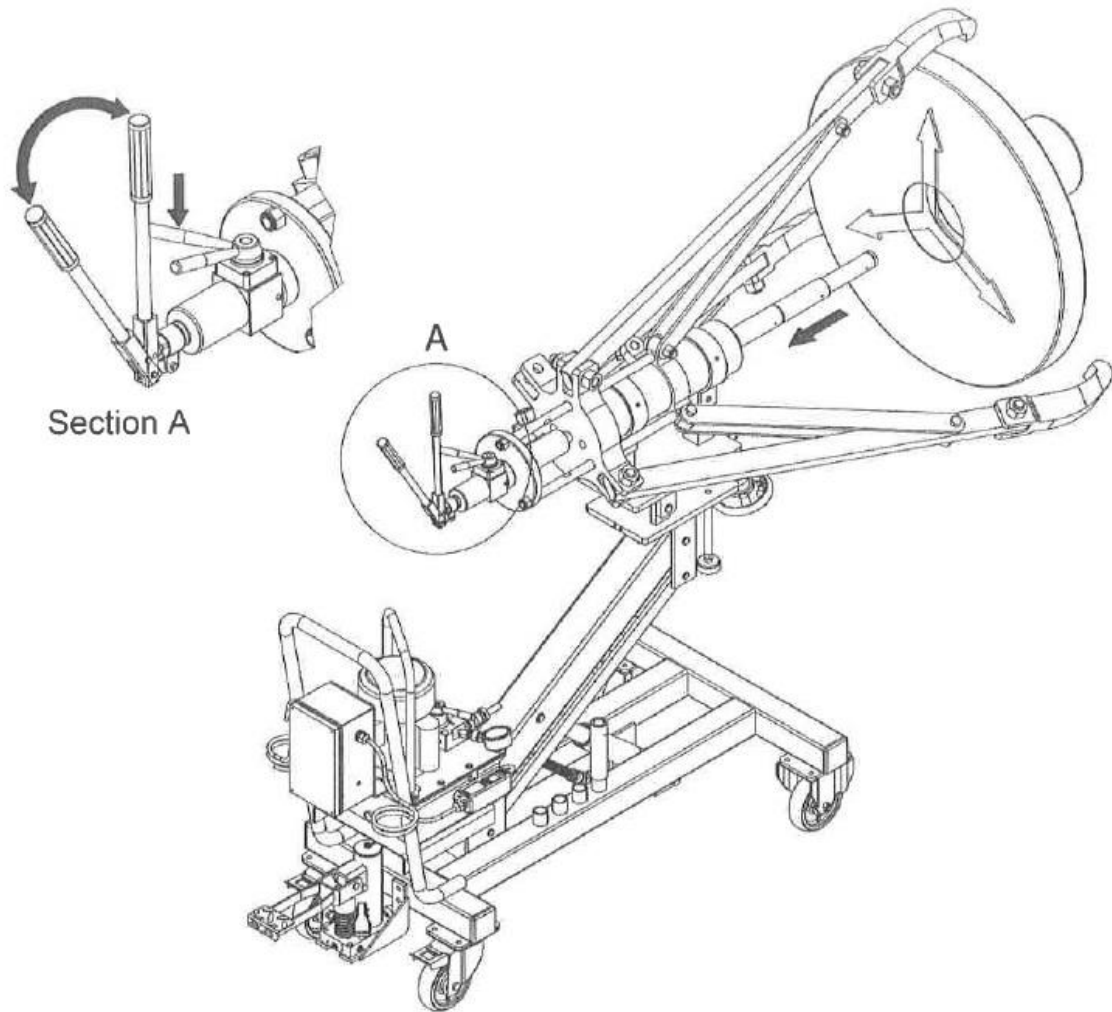

Figure 8 – Opening the Jaws

5.5 Conversion of 3-Jaw Puller to 2-Jaw Puller

Note - The 3-way combination is always followed whenever the job space allows for it because three jaws give a more secure grip and more even pulling force

Remove two sets of jaw and straps located on either side, away from the two symmetrical sections. Reassemble one set of jaw and straps on the other symmetrical section on the crosshead.

6.0 Maintenance



IMPORTANT:

- Use only good quality hydraulic fluid. **Do NOT** use brake fluid, transmission fluid, turbine oil, motor oil, alcohol, glycerine etc. Use of anything other than good quality hydraulic oil will void warranty and damage the pump, hose, and application. We recommend Durapac Hydraulic Oil or equivalent
- Equipment must only be serviced by a qualified hydraulic technician. For repair service, contact your local Durapac authorised service centre
- Tighten connections as needed. Use non-hardening pipe thread compound when servicing connections

Dirt, sand, etc. will quickly ruin any hydraulic system. Ensure that couplings are clean and free of foreign matter. After each use, clean couplings and attach dust caps.

Maintenance is required when wear or leakage is noticed. Periodically inspect all components to detect any problem that may require service and maintenance.

- 6.1 Check for loose connections and leaks.
- 6.2 Replace damaged parts immediately.
- 6.3 Do not exceed oil temperature above 60°C.
- 6.4 Keep all hydraulic components clean.
- 6.5 Use dust caps when puller is disconnected from the hose. Keep entire puller clean to prolong puller life.
- 6.6 Wipe thoroughly clean and store puller in the carry case (provided). Avoid temperature extremes.
- 6.7 Change hydraulic oil in your system as recommended in the pump instruction sheet.

7.0 Troubleshooting

Problem	Cause	Solution
Cylinder moves but does not maintain pressure	Leaking connection	<ul style="list-style-type: none"> • Clean, reseal with thread sealant and tighten connection
	Leaking cylinder seals	<ul style="list-style-type: none"> • Replace worn seals • Check for excessive contamination or wear • Replace contaminated fluid as necessary
	Malfunctioning pump/valve	<ul style="list-style-type: none"> • Repair or replace as necessary
Cylinder leaks hydraulic fluid	Worn or damaged seals	<ul style="list-style-type: none"> • Replace worn seals • Check for excessive contamination or wear • Replace contaminated fluid as necessary
	Loose connections	<ul style="list-style-type: none"> • Clean, reseal with thread sealant and tighten connection

Problem	Cause	Solution
Cylinder will not retract or retracts slower than normal	Closed pump release valve	<ul style="list-style-type: none"> Open pump release valve
	Loose couplers	<ul style="list-style-type: none"> Tighten couplers
	Blocked hydraulic lines	<ul style="list-style-type: none"> Clean and flush lines
	Weak or broken retraction springs	<ul style="list-style-type: none"> Send to a Durapac authorised service centre for repair
	Internally damaged cylinder	<ul style="list-style-type: none"> Send to a Durapac authorised service centre for repair
	Pump reservoir too full	<ul style="list-style-type: none"> Drain hydraulic fluid to correct level
Erratic Action	Air in system or pump cavitation	<ul style="list-style-type: none"> Add fluid, bleed air and check for leaks
	External leakage	<ul style="list-style-type: none"> Replace worn packings Check for excessive contamination fluid as necessary Replace contaminated fluid as necessary
	Sticking or binding cylinder	<ul style="list-style-type: none"> Check for dirt or leaks Check for bent, misaligned, worn parts or defective packings
Cylinder does not move	Loose couplers	<ul style="list-style-type: none"> Tighten couplers
	Faulty coupler	<ul style="list-style-type: none"> Verify that female coupler is not locked up (ball wedged into seat) Replace both male and female couplers
	Improper valve position	<ul style="list-style-type: none"> Close release valve or shift to new position
	Low or no hydraulic fluid in pump reservoir	<ul style="list-style-type: none"> Fill and bleed the system
	Air-locked pump	<ul style="list-style-type: none"> Add fluid, bleed air and check for leaks
	Load is above the capacity of the system	<ul style="list-style-type: none"> Use the correct equipment
Cylinder extends only partially	Low or no hydraulic fluid in pump reservoir	<ul style="list-style-type: none"> Fill and bleed the system
	Load is above the capacity of the system	<ul style="list-style-type: none"> Use the correct equipment
	Sticking or binding cylinder	<ul style="list-style-type: none"> Check for dirt or leaks Check for bent, misaligned, worn parts or defective packings
Cylinder moves slower than normal	Loose couplers	<ul style="list-style-type: none"> Tighten couplers
	Restricted hydraulic line or fitting	<ul style="list-style-type: none"> Clean Replace if damaged
	Low fluid level in pump reservoir	<ul style="list-style-type: none"> Fill and bleed the system
	Leaking cylinder seals	<ul style="list-style-type: none"> Replace worn seals Check for excessive contamination or wear Replace contaminated fluid as necessary

8.0 Parts Breakdown and List

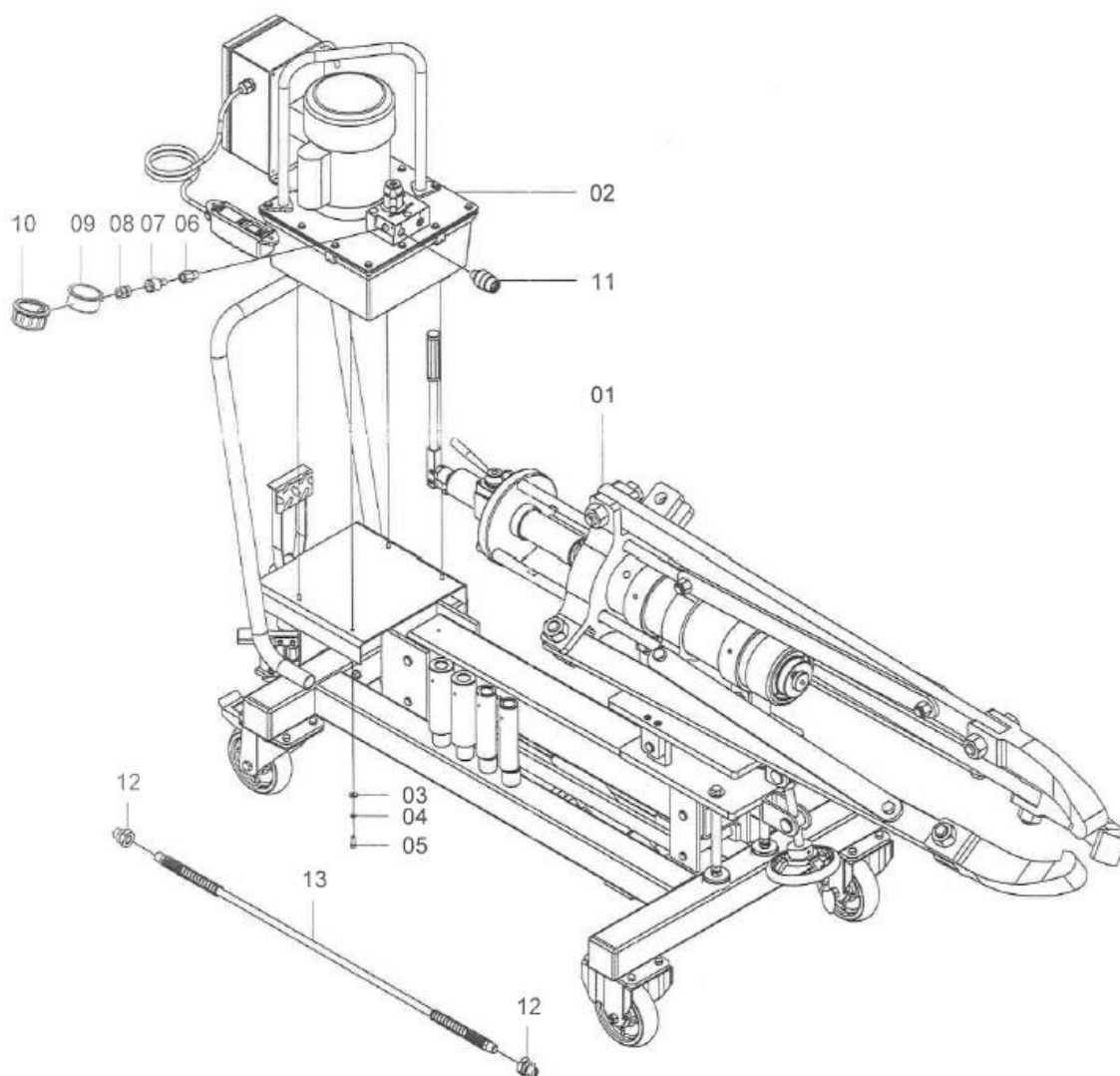

Item	Description	Part No.	Qty
1	Puller & Trolley Assembly	ZAL2060	1
2	Electric pump	ZAL2061	1
3	Washer	ZAL2062	4
4	Spring washer	ZAL1343	4
5	Screw	ZAL1296	4
6	Adaptor	ZAL1651	1
7	Quick coupler	ZAL1487	1
8	Quick coupler	ZAL1488	1
9	Gauge	ZAL2063	1
10	Protector	ZAL2064	1
11	Quick coupler	ZAL1472	1
12	Quick coupler	ZAL2065	2
13	High Flow Hose - 0.9 MTR	ZAL1958	1

* see following pages for further breakdown

8.1 ZAL2060 – Puller & Trolley Assembly

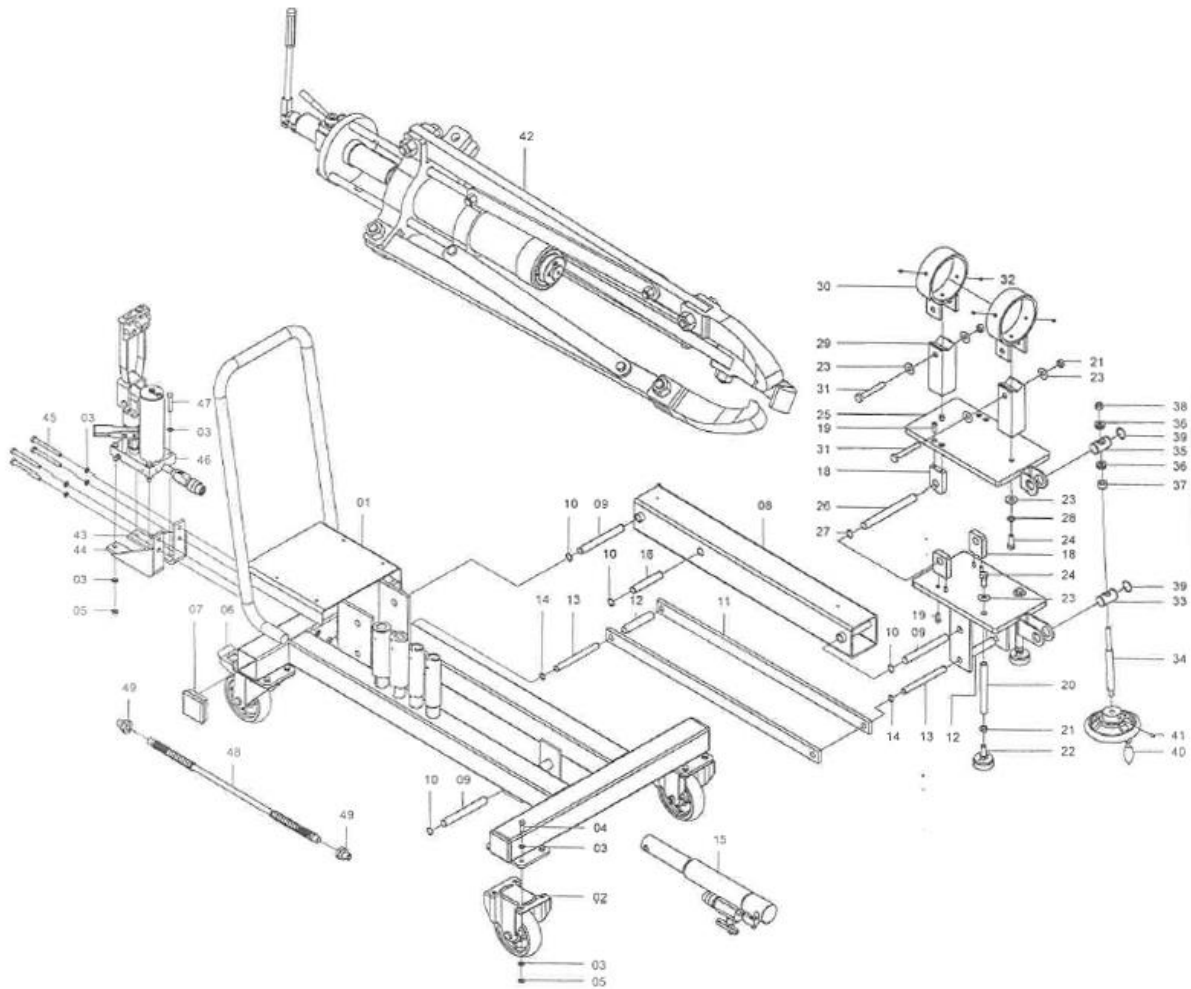

Item	Description	Part No.	Qty	Item	Description	Part No.	Qty
1	Trolley	ZAL2069	1	26	Pivot pin	ZAL2083	1
2	6" locking wheel	ZAL2070	2	27	Retaining ring	ZAL1777	2
3	Spring washer	ZAL1483	48	28	Spring washer	ZAL1793	2
4	Screw	ZAL1482	16	29	Ring support	ZAL2084	2
5	Nut	ZAL1484	24	30	Cylinder fixing ring	ZAL2085	2
6	6" wheel	ZAL2071	2	31	Screw	ZAL1796	2
7	Cover	ZAL2072	4	32	Screw	ZAL1284	4
8	Elevator arm	ZAL2073	1	33	Adjustment pin	ZAL2086	1
9	Long pin	ZAL2074	3	34	Tilt screw	ZAL2087	1
10	Snap ring	ZAL1663	8	35	Adjustment pin	ZAL2088	1
11	Guide arm	ZAL2075	2	36	Bearing	ZAL2089	2
12	Bushing	ZAL2076	2	37	Tilt screw bushing	ZAL2090	1
13	Guide arm pin	ZAL2077	2	38	Hex nut	ZAL1804	1
14	Snap ring	ZAL2038	4	39	Retaining ring	ZAL1328	4
15	Cylinder	ZAL2078	1	40	Steering wheel	ZAL2091	1
16	Short pin	ZAL2079	1	41	Screw	ZAL1826	1
17	Saddle base	ZAL2080	1	42	50 ton puller	ZAL2092	1
18	Angle fixing block	ZAL1788	4	43	Pump fixed support A	ZAL1950	1
19	Screw	ZAL1708	8	44	Pump fixed support B	ZAL1951	1
20	Adjustable bar	ZAL2081	2	45	Screw	ZAL1760	4
21	Nut	ZAL1785	4	46	Foot pump	ZAL1953	1
22	Adjustable screw arm	ZAL1786	2	47	Screw	ZAL1954	4
23	Washer	ZAL1764	8	48	Hose 0.6 MTR	ZAL1768	1
24	Screw	ZAL1983	4	49	Quick coupler	ZAL2065	2
25	Saddle plate	ZAL2082	1				

8.1.1 ZAL2092 – Puller Assembly

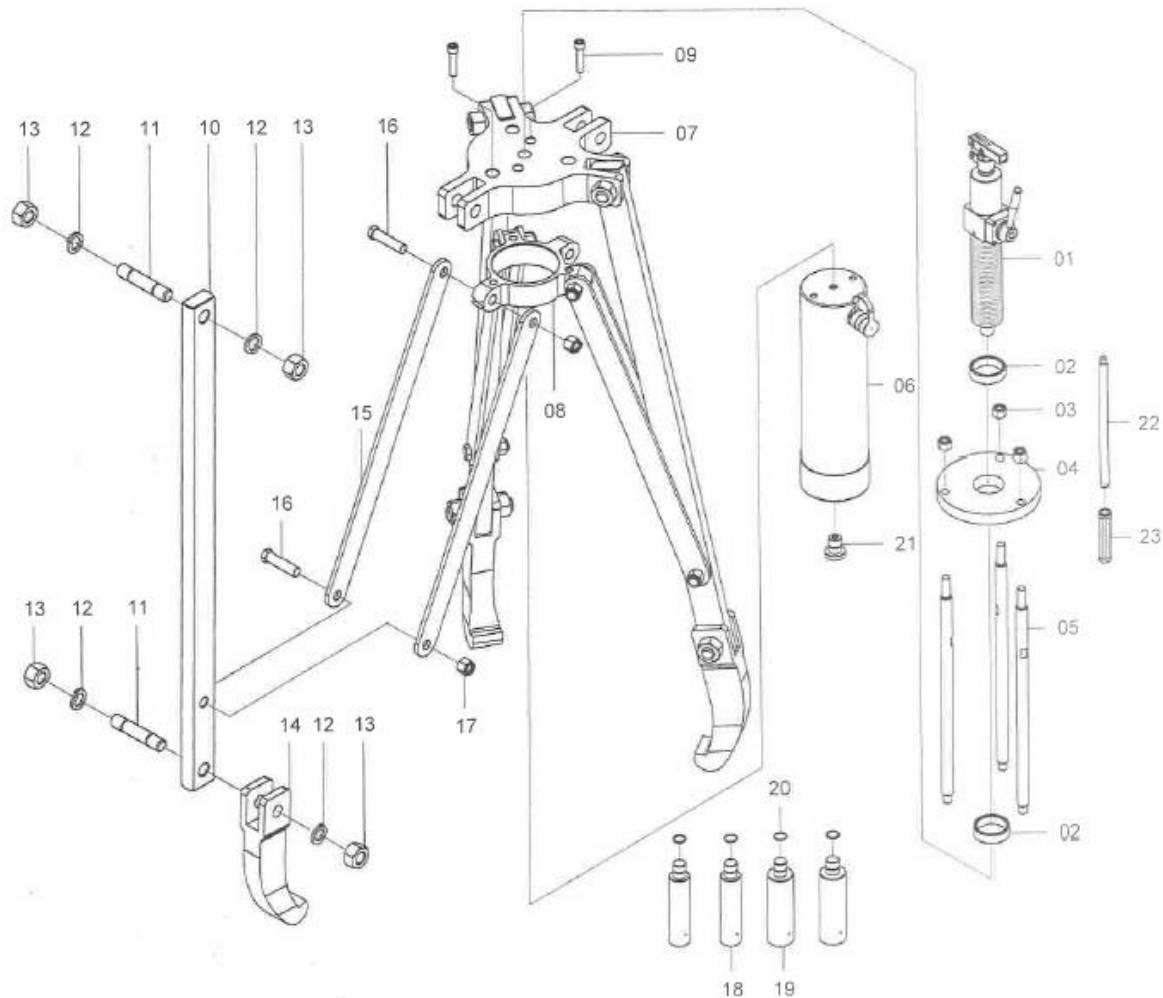

Item	Description	Part No.	Qty
1	Double acting cylinder	ZAL1397	1
2	Fixed ring	ZAL2066	2
3	Anti-loosen nut	ZAL1298	3
4	Fixed plate	ZAL2067	1
5	Supports	ZAL1473	3
6	Cylinder	ZAL2068	1
7	2/3 way puller crosshead	ZAL2093	1
8	2/3 way sliding socket	ZAL2094	1
9	Cap screw	ZAL2095	2
10	Puller jaw	ZAL2096	3
11	Jaw screw	ZAL2097	6
12	Spring washer	ZAL2098	12

Item	Description	Part No.	Qty
13	Nut	ZAL2099	12
14	Jaw head	ZAL2100	3
15	Puller jaw strap	ZAL2101	6
16	Screw	ZAL2102	6
17	Anti-loosen nut	ZAL1830	6
18	Extension bar A	ZAL2103	2
19	Extension bar B	ZAL2104	2
20	O-ring	ZAL2105	4
21	Removable cone assy	ZAL2106	1
22	Handle	ZAL2107	1
23	Handle grip	ZAL2108	1
24	Safety blanket	ZAL2109	1