

**DURAPAC**  
ENGINEERED FOR RELIABILITY

# Instruction Manual

Rotary Air Hydraulic Power Unit  
Model – DPR-173



**Maximum Operating Pressure – 700 bar**



This is a safety alert symbol. It is used to alert you to potential personal injury hazards. Obey all safety messages that follow this symbol to avoid injury or death

## 1.0 Product Information

DURAPAC – Rotary Air Hydraulic Power Units are engineered to meet Industrial Standards for Performance and Safety. The DPR-173 model is a two speed, high performance pump design that is ideally suited to applications where air is the preferred power source. The manual 2 way/2 position valve for Advance/Hold/Retract of a single acting cylinder/tool.

Note - HOLD is achieved in ADVANCE position with motor OFF.

Optional valve sub-plates offer pressure and flow control. Featuring a heavy-duty air motor with a motor ON/OFF air supply valve and 7.2 L usable oil reservoir.

Special skill, knowledge and training may be required for a specific task and the product may not be suitable for all jobs. The user must ultimately make the decision regarding suitability of the product for any given task and assume the responsibility of safety for all in the work area. Contact a Durapac representative if you are unsure of your power unit's suitability for a particular application.

## 2.0 Receiving Instructions

It is recommended prior to use that an inspection be done by qualified personnel and that any missing or damaged parts, decals, warning/safety labels or signs are replaced with Durapac authorised replacement parts only. Any power unit that appears to be damaged in any way, is worn, leaking or operates abnormally should be removed from service immediately until such time as repairs can be made. Any power unit that has been or suspected to have been subject to a shock load should be removed from service immediately until inspected by a Durapac authorised service centre. Owners and operators of this equipment should be aware that the use and subsequent repair of this equipment may require specialised training and knowledge.

## 3.0 Safety

Save these instructions. For your safety, read and understand the information contained within. The owner and operator should have an understanding of this product and safe operating procedures before attempting to use this product. Instructions and safety information should be conveyed in the operator's native language before use of this product is authorised. Make certain that the operator thoroughly understands the inherent dangers associated with the use and misuse of the product. If any doubt exists as to the safe and proper use of this product as outlined in this factory authorised manual, remove from service immediately.



### **DANGER:**

- To avoid personal injury keep hands and feet away from work area during operation
- **Do NOT** handle pressurized hoses. Escaping oil under pressure can penetrate the skin causing serious injury. If oil is injected under the skin, see a doctor immediately

- Stay clear of loads supported by hydraulics. A cylinder, when used as a load lifting device, should never be used as a load holding device. After the load has been raised or lowered, it must always be blocked mechanically

**WARNING:**

- The system operating pressure must not exceed the pressure rating of the lowest rated component in the system. Install pressure gauges in the system to monitor operating pressure. It is your window to what is happening in the system
- Always wear protective gear when operating hydraulic equipment. The operator must take precaution against injury due to failure of the tool or work piece(s)
- **Do NOT** hold or stand directly in line with any hydraulic connections while pressurising
- **Do NOT** attempt to disconnect hydraulic connections under pressure. Release all line pressure before disconnecting hoses
- All personnel must be clear before lowering load or depressurising the system
- **Do NOT** attempt to lift a load weighing more than the capacity of the cylinder

**IMPORTANT:**

- If at any stage, the safety related decals become hard to read, these must be replaced
- Minimum age of the operator must be 18 years. The operator must have read and understood all instructions, safety issues, cautions and warnings before starting to operate the equipment. The operator is responsible for this activity towards other persons
- **Do NOT** lift hydraulic equipment by the hoses or couplers. Use the carrying handle or other means of safe transport
- Hydraulic equipment must only be serviced by a qualified hydraulic technician. For repair service, contact the Durapac authorised service centre in your area. To protect your warranty, use only high-quality hydraulic oil

**CAUTION:**

- **KEEP HYDRAULIC EQUIPMENT AWAY FROM FLAMES AND HEAT.** Hydraulic fluid can ignite and burn. Excessive heat will soften packings and seals, resulting in fluid leaks. Heat also weakens hose materials and packings. For optimum performance do not expose equipment to temperatures of 65°C (150°F) or higher. Protect all equipment from weld spatter
- No alteration should be made to this device

### 3.1 Hydraulic Power Units

- **Do** use a gauge or other load measuring instrument to verify load
- **Do NOT** exceed the rated capacity of the power unit or any equipment in the system. Burst hazard exists if connection pressure exceeds rated pressure
- **Do NOT** operate the system with bent or damaged couplers or damaged threads
- **Do NOT** subject the power unit and its components to shock loads

- Use only Durapac approved accessories and components
- **Do NOT** connect to an application which can return more oil to the reservoir than the power unit reservoir can hold
- **Do NOT** connect power unit to a hydraulic system that is powered by another pump

### 3.2 Hydraulic Hoses & Fluid Transmission Lines

- Avoid short runs of straight-line tubing. Straight line runs do not provide for expansion and contraction due to pressure and/or temperature changes
- Reduce stress in tube lines. Long tubing runs should be supported by brackets or clips. Before operating the power unit, tighten all hose connections with proper tools. Do not over tighten. Connections should be tightened securely and leak-free. Over tightening can cause premature thread failure or high-pressure fittings to burst
- Should a hydraulic hose ever rupture, burst or need to be disconnected, immediately shut off the power unit and release all pressure. Never attempt to grasp a leaking pressurised hose with your hands. The force of escaping hydraulic fluid can inflict injury
- **Do NOT** subject the hose to potential hazard such as fire, sharp objects, extreme heat or cold or heavy impact
- **Do NOT** allow the hose to kink, twist, curl, crush, cut or bend so tightly that the fluid flow within the hose is blocked or reduced. Periodically inspect the hose for wear
- Hose material and coupler seals must be compatible with the hydraulic fluid used. Hoses also must not come in contact with corrosive materials such as battery acid, creosote-impregnated objects and wet paint. Never paint a coupler or hose

**FAILURE TO HEED THESE WARNINGS MAY RESULT IN PERSONAL INJURY AS WELL AS PROPERTY DAMAGE.**

## 4.0 Installation



### **IMPORTANT:**

- This power unit is for use with a single-acting cylinder **ONLY!** Connect a hose from the power unit's oil output port to the input port of a single-acting application such as a cylinder. Block the unused subplate port securely. This model **cannot** be used with a double-acting cylinder
- Always secure threaded port connections with high grade, non-hardening pipe thread sealant. Teflon tape can be used if only one layer of tape is used and it is applied carefully, two threads back, to prevent the tape from being introduced into hydraulic system, which could cause jamming of precision-fit parts
- To extend the life of your power unit, the air compressor should have a filter, regulator and lubricator system that will provide clean, lubricated air to the power unit. Contact your Durapac representative for the necessary accessories

- 4.1 Familiarise yourself with the specifications and illustrations in this owner’s manual. Know your power unit, its limitations and how it operates before attempting to use. Refer to the specification chart below for details of oil port thread size, usable oil capacity, and more. If in doubt, contact a Durapac representative.

Model Number	Used with Cylinder	Motor Size (kW)	Usable Oil Capacity (L)	Max. Pressure Rating (bar)	Pressure Rating (bar)		Oil Output Flow Rate (Lpm)		Valve Type	Valve Function	Air Pressure Range (bar)	Air Consumption (Lpm)	Sound Level (dB)	Weight (kg)
					1 <sup>st</sup> Stage	2 <sup>nd</sup> Stage	1 <sup>st</sup> Stage	2 <sup>nd</sup> Stage						
DPR-173	S/A	1.27	7.2	700	22	700	4.0	0.3	Manual 2W/2P	Advance/Hold*/Retract	5.6 - 7.0	1,246	93	21.5

\* HOLD in ADVANCE position with motor OFF

- 4.2 Check all system fittings and connections to be sure they are tight and leak free.
- 4.3 **Hydraulic Connection** - Connect oil output port to suitable fittings and application/cylinder.
- 4.4 **Air Connection** - After making the necessary hydraulic connections above, connect suitable air supply to air input port. Ensure that your air source can dedicate 1,246 Lpm @ a range of 5.6 – 7.0 bar for rated capacity performance.

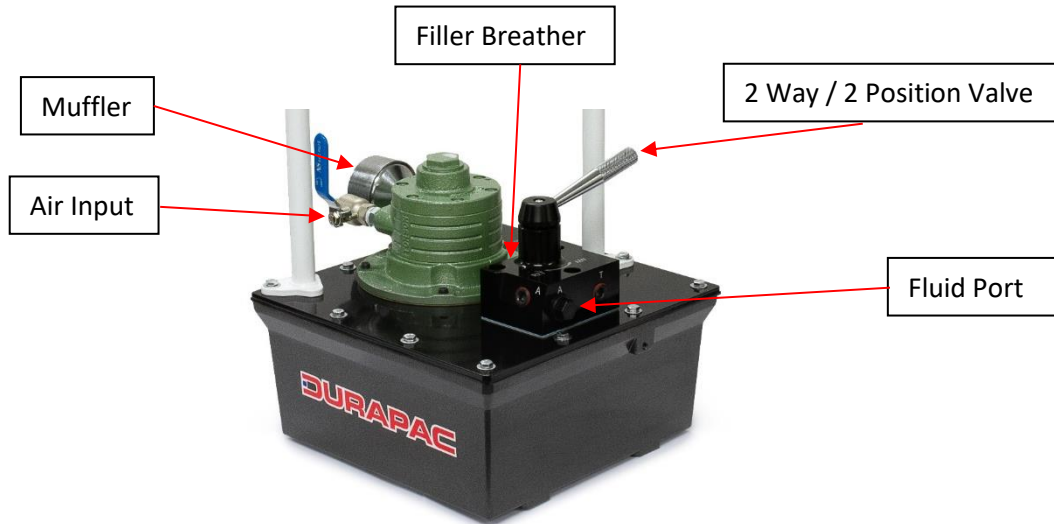

Figure 1 - DPR-173 Components

- 4.5 **Remove air from the power unit** – Air can accumulate in the hydraulic system during the initial setup or after prolonged use, causing the cylinder to respond slowly or in an unstable manner. Should removal of air from power unit be required, please follow the steps in 6.2 – Bleeding Air from the System in the Maintenance Section.
- 4.6 Check oil level in reservoir before operating power unit.

**5.0 Operation**



**IMPORTANT:**

- The air input pressure for the pump **must not** exceed 7 bar. If necessary, use a pressure reducer

- For producing the maximum oil output pressure, an air input pressure of 7 bar is required. The oil pressure is limited to 700 bar by an adjustable pressure relief valve regardless of the air input pressure
- Always monitor pressure, load or position using suitable equipment. Pressure may be monitored by means of an optional manifold and gauge. Do not load a hydraulic application (cylinder, spreader etc) to more than 80% of its rated capacity. Load may be monitored by means of a load cell and digital indicator. Correct application position can only be determined by the operator of the equipment
- **Do NOT** operate a power unit that is disconnected from the application. If operated in this condition, the hose and connections will become pressurised. This increases the chance of a burst hazard. Damage may also occur to the power unit and its components

### 5.1 To Start the Air Motor

- 5.1.1 Make the pneumatic and hydraulic connection.
- 5.1.2 Switch the air valve to start the air supply. Push the handle of the control valve to “Advance” to advance the cylinder.
- 5.1.3 To interrupt the ‘advance’ movement, turn the motor off (to ‘Hold’). This will stop the air supply. This will also prevent the pump from delivering oil which will keep the piston in its current position.
- 5.1.4 To retract the piston, push the handle of the control valve to “Return”. If required, ensure adequate load lowering control valves are installed.

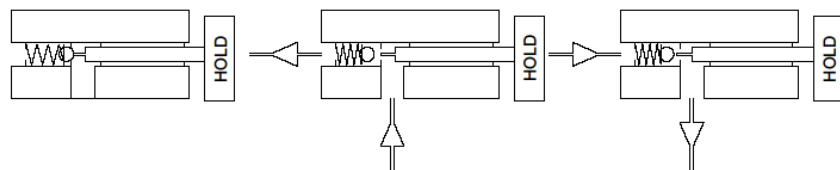

Figure 2 - Valve Function

### 6.0 Maintenance



**IMPORTANT:**

- Check oil level regularly
- Use only good quality hydraulic fluid. **Do NOT** use brake fluid, transmission fluid, turbine oil, motor oil, alcohol, glycerine etc. Use of anything other than good quality hydraulic oil will void warranty and damage the power unit, hose, and application. We recommend Durapac Hydraulic Oil or equivalent
- Equipment must only be serviced by a qualified hydraulic technician. For repair service, contact your local Durapac authorised service centre
- Damage to hydraulic hoses may not be detected during visual inspections. For this reason, Durapac recommends that hydraulic hoses be replaced on a regular basis
- Tighten connections as needed. Use non-hardening pipe thread compound when servicing connections

Dirt, sand, etc. will quickly ruin any hydraulic system. Ensure that couplings are clean and free of foreign matter. After each use, clean couplings and attach dust caps.

Maintenance is required when wear or leakage is noticed. Periodically inspect all components to detect any problem that may require service and maintenance.

## 6.1 Adding Hydraulic Fluid

 **WARNING:** Always add oil with cylinders fully retracted (or extended, if pull cylinders) or the system will contain more oil than the reservoir can hold

- 6.1.1 Depressurise and disconnect hydraulic hose from application/cylinder.
- 6.1.2 With the power unit in an upright, horizontal position, remove the air vent plug located on the top plate of the reservoir.
- 6.1.3 Use a small funnel to fill the reservoir to within 19mm (3/4") of the opening.
- 6.1.4 Bleed air from system if necessary.
- 6.1.5 Wipe up any spilled fluid and reinstall the air vent plug/reservoir cap.

## 6.2 Bleeding Air from the System

- 6.2.1 Repeat Steps 6.1.1 to 6.1.3 (above), if required.
- 6.2.2 Invert cylinder and place at a lower level than the power unit reservoir.
- 6.2.3 Extend and retract the cylinder several times without putting a load on the system. Air will be released into the power unit reservoir.
- 6.2.4 Recheck oil level after removing air.

## 6.3 Changing Hydraulic Fluid

 For best results, change fluid once a year or every 300 hours of use

- 6.3.1 Repeat Steps 6.1.1 to 6.1.2 (above).
- 6.3.2 Pour used fluid into a sealable container.
- 6.3.3 Repeat Steps 6.1.3 to 6.1.5 (above).
- 6.3.4 Dispose of fluid in accordance with local regulations.

## 6.4 Lubrication

When power unit is operated daily, it is recommended that an inline oiler and air dryer is installed and SAE grade oil (5W to 30W) is used.

## 6.5 Storage

- 6.5.1 When not in use, depressurise and disconnect the hydraulic power unit from the application.
- 6.5.2 Wipe clean thoroughly and store in a clean, dry environment. Avoid temperature extremes.

- 6.5.3 For transportation or long storage, replace the air vent plug with shipping plug.
- 6.5.4 Shield power unit with a protective cover.



**7.0 Troubleshooting**

<b>Problem</b>	<b>Cause</b>	<b>Solution</b>
<b>Application does not extend, move or respond to pressurised fluid</b>	Overload condition	<ul style="list-style-type: none"> <li>Remedy overload condition</li> </ul>
	Loose couplers	<ul style="list-style-type: none"> <li>Tighten couplers</li> </ul>
	Faulty couplers	<ul style="list-style-type: none"> <li>Replace couplers</li> </ul>
	Malfunctioning power unit	<ul style="list-style-type: none"> <li>Contact a Durapac authorised service centre</li> <li>Repair or replace as necessary</li> </ul>
	Inadequate air supply	<ul style="list-style-type: none"> <li>Ensure the air source can dedicate 1,246 Lpm @ a range of 5.6 – 7 bar for the 1.27kW power unit</li> </ul>
<b>Application responds to pressurised fluid, but system does not maintain pressure</b>	Overload condition	<ul style="list-style-type: none"> <li>Remedy overload condition</li> </ul>
	Malfunctioning power unit or valve	<ul style="list-style-type: none"> <li>Contact a Durapac authorised service centre</li> <li>Repair or replace as necessary</li> </ul>
	Leaking application/connection	<ul style="list-style-type: none"> <li>Replace application/connection</li> </ul>
<b>Application responds slower than normal</b>	Loose connection or coupler	<ul style="list-style-type: none"> <li>Tighten connection or coupler</li> </ul>
	Restricted hydraulic line or fitting	<ul style="list-style-type: none"> <li>Clean and replace if damaged</li> </ul>
	Leaking application/connection	<ul style="list-style-type: none"> <li>Replace application/connection</li> </ul>
<b>Application does not return fluid to power unit (i.e. cylinder will not retract)</b>	Malfunctioning coupler/ damaged application	<ul style="list-style-type: none"> <li>Secure load by other means</li> <li>Depressurise power unit and hose</li> <li>Remove coupler and/or application</li> <li>Repair or replace as necessary</li> </ul>
<b>Application does not fully extend (cylinder or spreader)</b>	Overfilled reservoir	<ul style="list-style-type: none"> <li>Secure load by other means</li> <li>Depressurise power unit and hose</li> <li>Remove application</li> <li>Drain fluid to proper level</li> </ul>
	Low fluid level in power unit	<ul style="list-style-type: none"> <li>Secure load by other means</li> <li>Depressurise power unit and hose</li> <li>Remove application</li> <li>Fill fluid to proper level</li> </ul>
<b>Poor performance</b>	Low fluid level in power unit	<ul style="list-style-type: none"> <li>Ensure proper fluid level</li> </ul>

8.0 Parts Breakdown & List

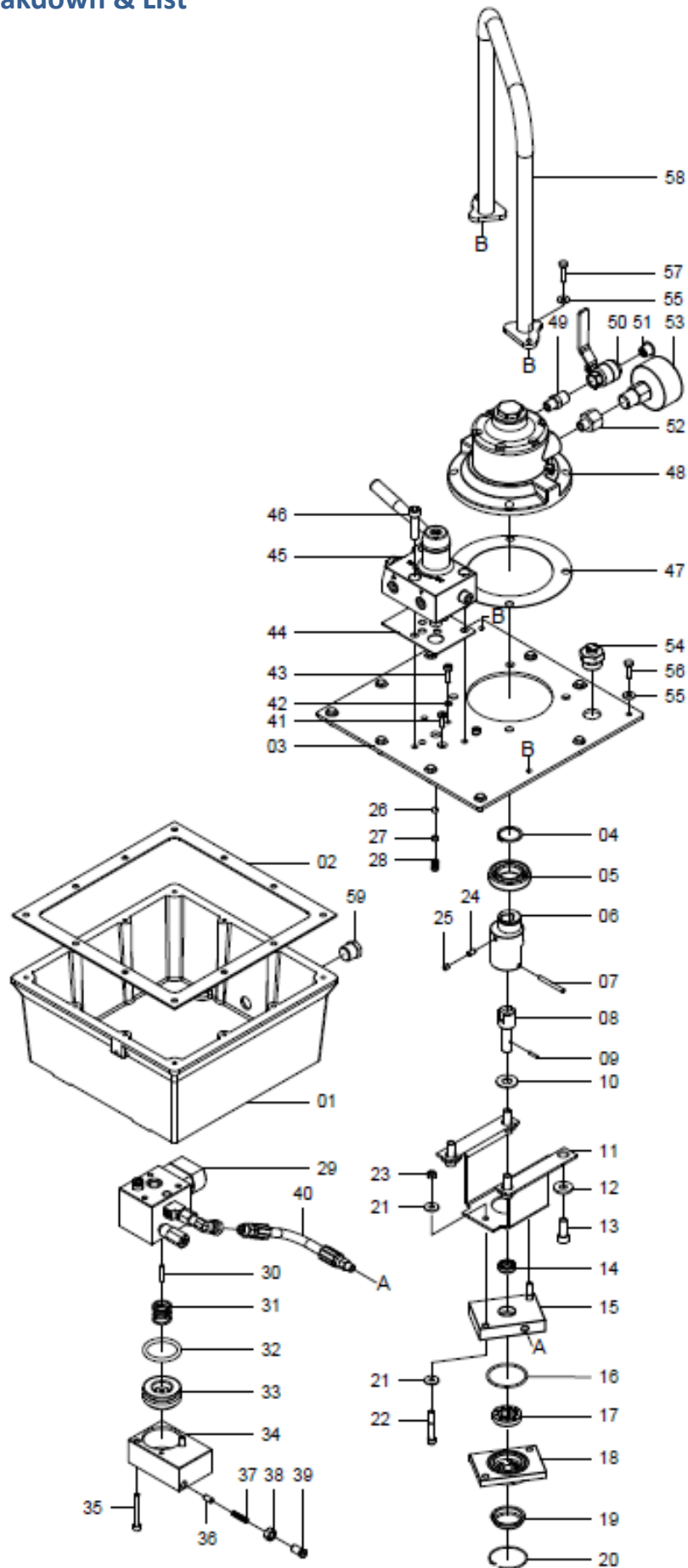

Item	Description	Part No.	Qty	Item	Description	Part No.	Qty
1	Reservoir assembly	ZAL2129	1	31	Compression spring	ZAL2153	1
2	Reservoir gasket	ZAL1260	1	32	O-ring	ZAL2154	1
3	Cover plate	ZAL2130	1	33	Automatic valve piston	ZAL2155	1
4	Retaining ring	ZAL1328	1	34	Automatic valve block	ZAL2156	1
5	Ball bearing	ZAL2131	1	35	Cap screw	ZAL2157	2
6	Eccentric	ZAL2132	1	36	Dowel pin	ZAL2158	1
7	Spring pin	ZAL2133	1	37	Compression spring	ZAL2159	1
8	Drive shaft	ZAL2134	1	38	Lock nut	ZAL2160	1
9	Gerotor dowel pin	ZAL2135	1	39	Adjusting screw	ZAL2161	1
10	Brass washer	ZAL2136	1	40	Hose assembly	ZAL2162	1
11	Pump mounting bracket	ZAL2137	1	41	Screw	ZAL2163	1
12	Washer	ZAL2138	4	42	Washer	ZAL2164	2
13	Cap screw	ZAL2139	4	43	Bolt	ZAL1296	2
14	Seal	ZAL2140	1	44	Valve gasket	ZAL1255	1
15	Upper gerotor housing	ZAL2141	1	45	Valve assembly	ZAL1027	1
16	O-ring	ZAL2142	1	46	Cap screw	ZAL2178	1
17	Gerotor set	ZAL2143	1	47	Motor seal	ZAL2166	1
18	Lower gerotor housing	ZAL2144	1	48	Air motor	ZAL2167	1
19	Filter	ZAL2145	1	49	Hesagon nipple	ZAL2168	1
20	Spring ring	ZAL2146	1	50	Ball check valve	ZAL2169	1
21	Washer	ZAL1550	4	51	Cap	ZAL2127	1
22	Cap screw	ZAL2147	2	52	Adaptor	ZAL2170	1
23	Nut	ZAL2148	2	53	Silencer	ZAL2171	1
24	Screw	ZAL2149	1	54	Breather assembly	ZAL2172	1
25	Screw	ZAL2150	1	55	Washer	ZAL2173	12
26	Steel ball	ZAL1368	1	56	Screw	ZAL2174	10
27	Spring end cap	ZAL1144	1	57	Screw	ZAL2175	2
28	Spring	ZAL1360	1	58	Handle	ZAL2176	1
29	Check body	ZAL2151	1	59	Set screw	ZAL2177	1
30	Dowel pin	ZAL2152	1				

Serial, model and part numbers need to be quoted when ordering parts.