

DURAPAC
ENGINEERED FOR RELIABILITY

Instruction Manual

100 Ton Hydraulic Roller Bearing
Puller/Pusher - Model – DRP-100E



Maximum Operating Pressure – 700 bar



This is a safety alert symbol. It is used to alert you to potential personal injury hazards. Obey all safety messages that follow this symbol to avoid injury or death

1.0 Product Information

DURAPAC – Hydraulic Pullers are engineered to meet Industrial Standards for Performance and Safety. The DRP-100E model uses a double acting hydraulic system for pulling and pushing. They also feature the following:

- Easy and efficient removal or installation of railroad axle journal tapered roller bearings
- Designed for use with major bearing brands
- Portable design for convenient positioning and storage
- Accessory sets available for all common bearing classes
- Supplied with a 230V electric power unit

Special skill, knowledge and training may be required for a specific task and the product may not be suitable for all jobs. The user must ultimately make the decision regarding suitability of the product for any given task and assume the responsibility of safety for all in the work area. Contact a Durapac representative if you are unsure of your puller's suitability for a particular application.

2.0 Receiving Instructions

It is recommended prior to use that an inspection be done by qualified personnel and that any missing or damaged parts, decals, warning/safety labels or signs are replaced with Durapac authorised replacement parts only. Any puller that appears to be damaged in any way, is worn, leaking or operates abnormally should be removed from service immediately until such time as repairs can be made. Any puller that has been or suspected to have been subject to a shock load should be removed from service immediately until inspected by a Durapac authorised service centre. Owners and operators of this equipment should be aware that the use and subsequent repair of this equipment may require specialised training and knowledge.

3.0 Safety

Save these instructions. For your safety, read and understand the information contained within. The owner and operator should understand this product and safe operating procedures before attempting to use this product. Instructions and safety information should be conveyed in the operator's native language before use of this product is authorised. Make certain that the operator thoroughly understands the inherent dangers associated with the use and misuse of the product. If any doubt exists as to the safe and proper use of this product as outlined in this factory authorised manual, remove from service immediately.



DANGER:

- To avoid personal injury keep hands and feet away from work area during operation
- **Do NOT** handle pressurised hoses. Escaping oil under pressure can penetrate the skin causing serious injury. If oil is injected under the skin, see a doctor immediately
- Stay clear of loads supported by hydraulics. A cylinder, when used as a load lifting device, should never be used as a load holding device. After the load has been raised or lowered, it must always be supported mechanically

**WARNING:**

- The system operating pressure must not exceed the pressure rating of the lowest rated component in the system. Install pressure gauges in the system to monitor operating pressure. It is your window to what is happening in the system
- Always wear appropriate personal protective equipment (PPE) when operating hydraulic equipment. The operator must take precaution against injury due to failure of the tool or work piece(s)
- **Do NOT** hold or stand directly in line with any hydraulic connections while pressurising
- **Do NOT** attempt to disconnect hydraulic connections under pressure. Release all line pressure before disconnecting hoses
- All personnel must be clear before lowering load or depressurising the system
- **Do NOT** attempt to lift a load weighing more than the capacity of the cylinder

**IMPORTANT:**

- If at any stage, the safety related decals become hard to read, these must be replaced
- Minimum age of the operator must be 18 years. The operator must have read and understood all instructions, safety issues, cautions and warnings before starting to operate the equipment. The operator is responsible for this activity towards other persons
- **Do NOT** lift hydraulic equipment by the hoses or couplers. Use the carrying handle or other means of safe transport
- Hydraulic equipment must only be serviced by a qualified hydraulic technician. For repair service, contact the Durapac authorised service centre in your area. To protect your warranty, use only high-quality hydraulic oil

**CAUTION:**

- **KEEP HYDRAULIC EQUIPMENT AWAY FROM FLAMES AND HEAT.** Hydraulic fluid can ignite and burn. Excessive heat will soften packings and seals, resulting in fluid leaks. Heat also weakens hose materials and packings. For optimum performance do not expose equipment to temperatures of 65°C (150°F) or higher. Protect all equipment from weld spatter
- No alteration should be made to this device

3.1 Hydraulic Pullers

- Do not hammer on or near any part of this unit. Sharp or sudden impacts can cause undue stress on highly loaded parts
- Stand to the side of the puller and back as far as the remote-control cord will allow during bearing removal or installation in case of part breakage
- Align the puller on the same centreline as the part being removed. Failure to align the parts correctly can result in a dangerous operating situation because of the high hydraulic pressure used

- Before applying pressure, wrap the work in a safety blanket/ sheath to protect from injury caused by flying parts should a part ever break
- **Do NOT** heat the part to be removed. When the puller comes in contact with the part, heating can result in damage to components of the puller
- Apply force gradually
- Ensure that the puller jaws are fully engaged with the workpiece being pulled
- **Do NOT** overload equipment. Overloading can cause equipment failure and possible personal injury. **Do** use a gauge or other load measuring instrument to verify load
- This device is not suitable for use as a support device! As the system load is lifted, use blocking and cribbing to guard against a falling load
- **Do NOT** overextend the puller
- Only operate within the limits of the pullers' rated stroke
- **Never** pressurise uncoupled couplers. Only use hydraulic equipment in a coupled system
- Use only Durapac approved accessories and components

3.2 Hydraulic Hoses & Fluid Transmission Lines

- Avoid short runs of straight-line tubing. Straight line runs do not provide for expansion and contraction due to pressure and/or temperature changes
- Reduce stress in tube lines. Long tubing runs should be supported by brackets or clips. Before operating the pump, connections should be tightened securely and leak-free. Over tightening can cause premature thread failure or high-pressure fittings to burst
- Should a hydraulic hose ever rupture, burst or need to be disconnected, immediately shut off the pump and release all pressure. Never attempt to grasp a leaking pressurised hose with your hands. The force of escaping hydraulic fluid can inflict injury
- **Do NOT** subject the hose to potential hazard such as fire, sharp objects, extreme heat or cold or heavy impact
- **Do NOT** allow the hose to kink, twist, curl, crush, cut or bend so tightly that the fluid flow within the hose is blocked or reduced. Periodically inspect the hose for wear
- Hose material and coupler seals must be compatible with the hydraulic fluid used. Hoses also must not come in contact with corrosive materials such as battery acid, creosote-impregnated objects and wet paint. Never paint a coupler or hose

FAILURE TO HEED THESE WARNINGS MAY RESULT IN PERSONAL INJURY AS WELL AS PROPERTY DAMAGE.

4.0 Installation

⚠ IMPORTANT: Always secure threaded port connections with high grade, non-hardening pipe thread sealant. Teflon tape can be used if only one layer of tape is used and it is applied carefully, two threads back, to prevent the tape from being introduced into hydraulic system, which could cause jamming of precision-fit parts

4.1 Familiarise yourself with the specifications and illustrations in this owner’s manual. Know your puller, its limitations and how it operates before attempting to use. Refer to the specification chart below or if in doubt, contact a Durapac representative.

Model Number	Stroke (mm)	Pull Capacity (ton)	Push Capacity (ton)	Weight incl. oil & frame (kg)
DRP-100E	392	100	68	455

MODEL DRP-100E Units are supplied completely assembled. The following steps are for reference only.

- a) Connect one 40" hose from port ‘A’ to the pressure regulator valve (shown below in Figure 1).
- b) Connect the other 40" hose from port ‘B’ to the rod end cylinder port.
- c) Operate the unit, with the cylinder in the lowest position, three or more times until it advances and retracts smoothly.

Note - if the hoses are connected incorrectly, the remote-control switch will operate the cylinder in reverse of what the decal indicates.

EXTERNAL PRESSURE REGULATOR

The pressure regulator valve allows the operator of the bearing puller / pusher to limit the pressure on the return stroke of the cylinder when the journal axle bearing is being installed. The pressure regulator valve has been set at 415 bar (6,000 psi). The maximum force (output) of the cylinder at 415 bar when the piston is being retracted is 40 tons (with the shut-off valve open).

Note - if the maximum force of the cylinder is needed for bearing installation, the shut-off valve should be closed.

- 4.2 Fill pump reservoir to proper operating level using approved Hydraulic Oil.
- 4.3 Connect pump power cord to proper power source (230V single phase 15 amp) and release the foot type bottle jack to lower puller cylinder to the lowest position. Start pump and cycle pulling cylinder to full extension, then to full retraction, three or more times until the cylinder advances and retracts smoothly throughout the cycle.
- 4.4 Allow the pump to build to full pressure with the cylinder first fully extended, and then fully retracted. Stop pump and check each hose, fitting, and other system components for any oil leakage. If any leakage is found, correct the problem, and reset.

- 4.5 Install proper tooling on puller and operate puller following the instructions for "Removing or Installing the TIMKEN 'AP' or 'Hyatt HY-roll Taper' Bearing (or similar)" as written in this instruction manual.

5.0 Operation

5.1 Adjusting the Pressure Regulator Valve

Note - for easy adjustment of the pressure regulator valve, always adjust the pressure by **INCREASING** it to a desired pressure setting. The pressure range for this unit is 70 – 700 bar (1,000 to 10,000 psi).

- 5.1.1 Loosen the locknut on the pressure regulator valve. Turn the adjusting screw counterclockwise for a few turns, to decrease the pressure setting to a lower than desired pressure.
- 5.1.2 Open the shut-off valve.
- 5.1.3 Place the 4-way control valve in the return position.
- 5.1.4 Start the pump and build pressure on the return side of the regulator valve. Slowly turn the adjusting screw in a clockwise direction to gradually increase the pressure setting. When the desired pressure setting is reached, lock the adjusting screw into position by tightening the locknut.

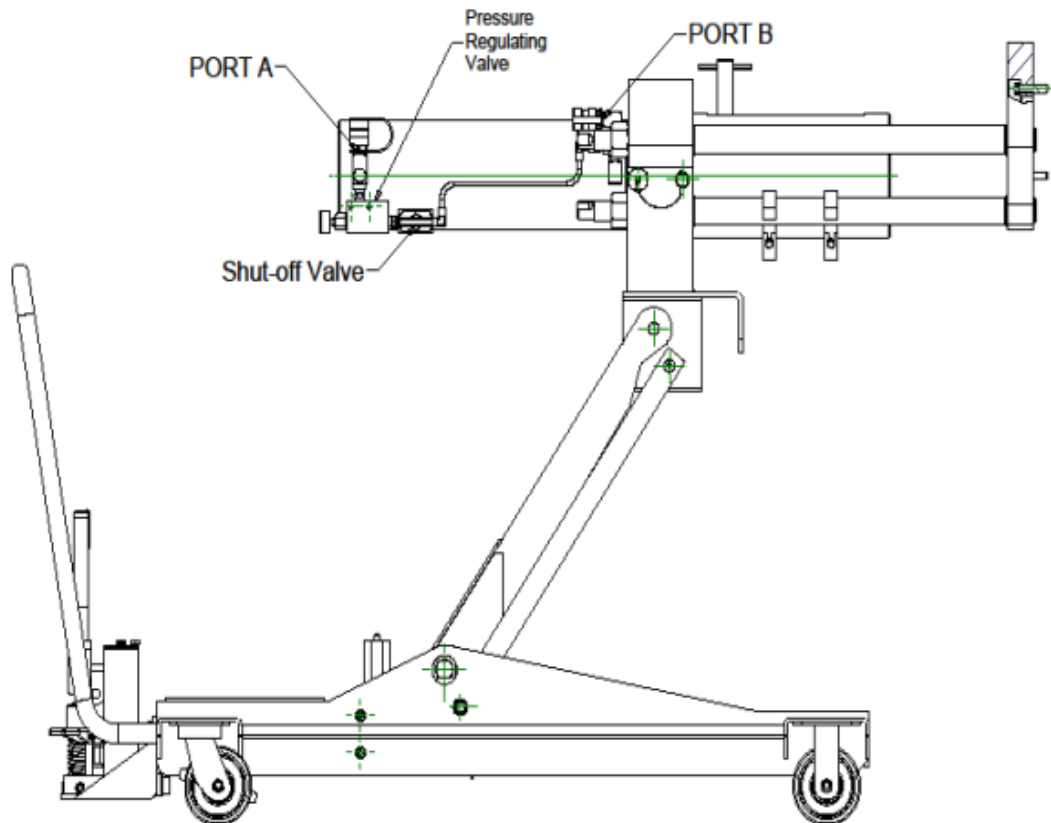

Figure 1 – Adjusting the Pressure Regulator Valve

REMOVING OR INSTALLING THE TIMKEN "AP" OR "HYATT HY-ROLL TAPER" BEARING (OR SIMILAR)



⚠ Always follow the bearing manufacturer's installation or removal procedures. These guideline instructions are for typical application only

The instructions that follow cover a typical application involving the use of a Durapac Bearing Puller / Pusher and illustrate the steps necessary to remove and install roller bearings with this unit. The adaptors and accessories which will be required to remove and install these bearings will be determined by the manufacturer when furnished with the following information concerning the bearing to be serviced; Bearing manufacturer's name; bearing manufacturer's general arrangement drawing number; size of bearing to be serviced; railroad name and location; and part number of the adaptors which are in your possession if you presently own a puller / pusher.

Note: We strongly recommend securely wrapping the work to be pulled or installed with a suitable ballistic nylon protective blanket to help protect the users and others from possible injury should a part break while applying pressure.

5.2 Bearing Removal

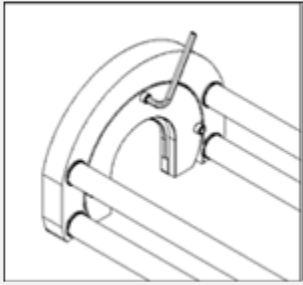
⚠ Refer to bearing manufacturer's service manual for steps to be taken prior to the actual removal of the bearing

<p>5.2A</p>	<p>The following instructions should be followed when <u>only a few bearings are to be removed.</u></p>	
<p>5.2A.1</p>	<p>Select the proper Pulling Shoe and attach it to the Pulling Frame Legs if this has not already been done (Figure 2).</p>	 <p><i>Figure 2 – Shoe Selection</i></p>
<p>5.2A.2</p>	<p>Attach the Guide Tube Adaptor to the end of axle with the Cap Screws provided (Figure 3).</p>	 <p><i>Figure 3 – Guide Tube Adaptor Attachment</i></p>

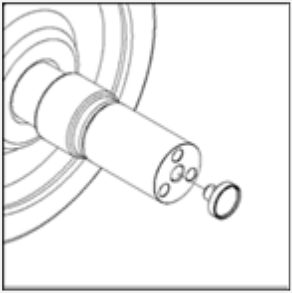
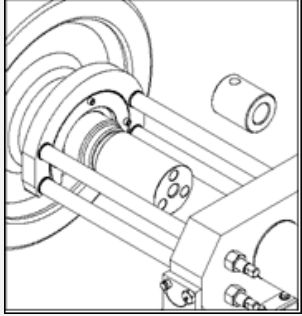
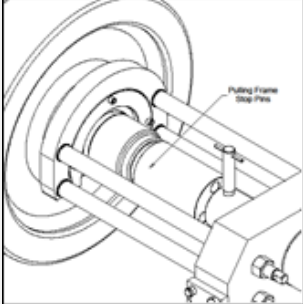
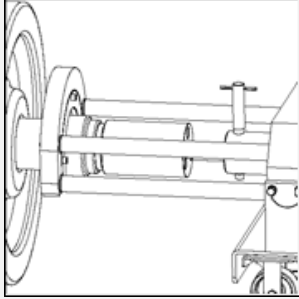
<p>5.2A.3</p>	<p>Insert the Guide Tube Adaptor into the threaded hole in the Guide Tube. The Guide Tube Adaptor is retained by a spring-loaded ball and is not threaded (Figure 4).</p>	 <p><i>Figure 4 – Inserting Adaptor into Guide Tube</i></p>
<p>5.2A.4</p>	<p>Roll the bearing puller / pusher into position. Remove the Puller Frame Stop Pins and tilt the Pulling Frame so that it is positioned directly above the Bearing Assembly. Place the Forcing Plug Adaptor in the Piston Rod Coupling (Figure 5).</p>	 <p><i>Figure 5 – Puller Positioning</i></p>
<p>5.2A.5</p>	<p>Lower the Pulling Frame so that the Pulling Shoe fits behind the bearing backing ring and replace the Pulling Frame Stop Pins.</p> <p>Note - The Bearing Puller / Pusher must be aligned with the axle. It may be necessary to adjust the Pulling Frame for height to assure correct vertical alignment of the Bearing Puller / Pusher.</p>	
<p>5.2A.6</p>	<p>After adjusting the pulling Frame for height, hold the Pulling Shoe in position behind the bearing backing ring until initial pressure has been applied to the bearing assembly (Figure 6).</p>	 <p><i>Figure 6 – Puller Positioning</i></p>
<p>5.2A.7</p>	<p>If the Pulling Shoe has engaged the bearing backing ring properly and the entire setup is properly aligned (Figure 7), stand to the side of the puller and back as far as the remote-control cord will allow. Continue to apply pressure, extending the Piston Rod until the bearing assembly has been removed from the axle and is resting on the Guide Tube.</p>	 <p><i>Figure 7 – Correct Alignment</i></p>

5.2A.8	When the bearing assembly is removed from the Guide Tube, a cardboard tube, like the shipping tube which originally accompanied the bearing assembly, should be used to hold the internal bearing parts in place. Particular attention should be given to keeping the seal wear rings in place in the enclosure seals.
--------	--

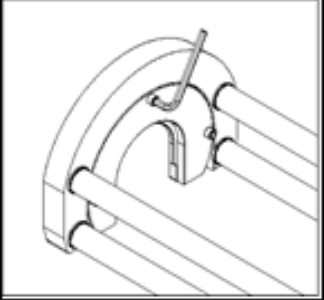
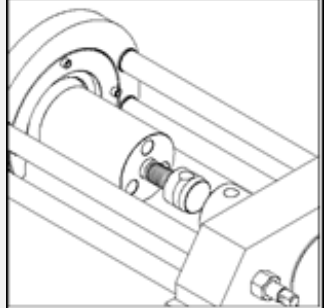
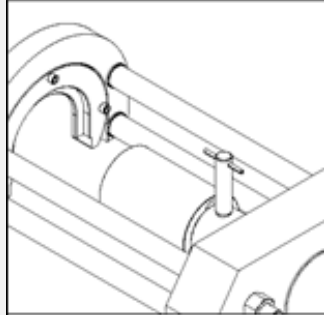
5.2B	<p>The following instructions should be followed when <u>several bearing assemblies of the same size are to be removed.</u></p>	
5.2B.1	<p>Upon determining the bearing size, select the proper Pulling Shoe Adaptor and attach it to the Pulling Frame (Figure 8).</p>	 <p>Figure 8 – Shoe Selection</p>
5.2B.2	<p>Attach the Guide Tube to the Piston Rod Coupling by threading the Installing Adaptor into the Guide Tube (Figure 9).</p>	 <p>Figure 9 – Guide Tube Adaptor Attachment</p>
5.2B.3	<p>Attach this assembly to the Piston Rod Coupling with the Connector Pin (Figure 10). The Guide Tube must be tightened against the Piston Rod Coupling so that the pressure required to remove the bearing assembly will not shear or bend the Connector Pin.</p>	 <p>Figure 10 – Attaching with the Connector Pin</p>

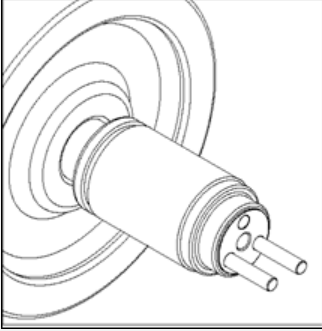
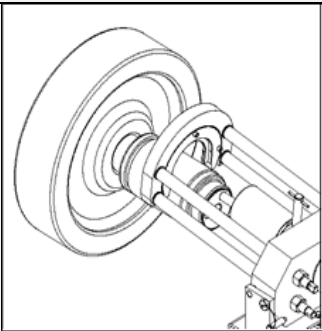
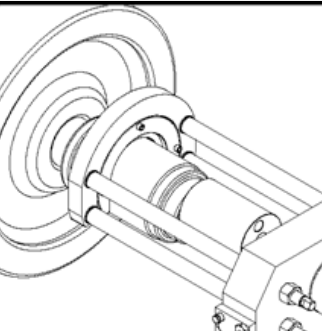
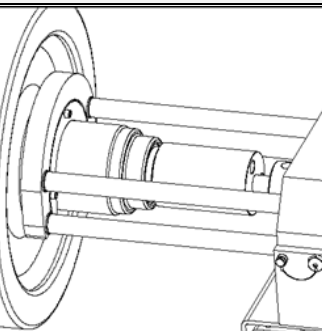
<p>5.2B.4</p>	<p>Thread two Guide Pins into the axle to align the Guide Tube with the axle for the pulling operation (Figure 11).</p> <p>Note - Guide Pins are not supplied. Guide Pins are strictly a user part and must be determined by the user.</p>	 <p>Figure 11 – Guide Tube Alignment</p>
<p>5.2B.5</p>	<p>Roll the Bearing Puller / Pusher into position. Remove the Puller Frame Stop Pins and tilt the Pulling Frame so that it is positioned directly above the Bearing Assembly (Figure 12).</p>	 <p>Figure 12 – Puller Positioning</p>
<p>5.2B.6</p>	<p>Lower the pulling Frame so that the Pulling Shoe fits behind the bearing backing ring and the Guide Pins are in alignment with the holes in the Guide Tube. Replace the Pulling Frame Stop Pins. The Bearing Puller / Pusher must be in alignment with the axle. It may be necessary to adjust the Pulling Frame for height. Hold the Pulling Shoe in Position behind the bearing backing ring until initial pressure has been applied to the bearing assembly (Figure 13).</p>	 <p>Figure 13 – Puller Alignment</p>
<p>5.2B.7</p>	<p>If the Pulling Shoe has engaged the bearing backing ring properly and the entire setup is properly aligned (Figure 14), stand to the side of the puller and back as far as the remote-control cord will allow and continue to apply pressure, extending the Piston Rod until the bearing assembly has been removed from the axle and is resting on the Guide Tube (Figure 14).</p>	 <p>Figure 14 – Correct Alignment</p>

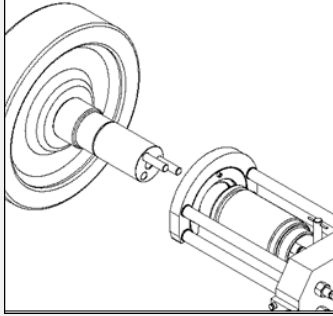
<p>5.2B.8</p>	<p>When the bearing assembly is removed from the Guide Tube, a cardboard tube, like the shipping tube which originally accompanied the bearing assembly, should be used to hold the internal bearing parts in place. Particular attention should be given to keeping the seal wear rings in place in the enclosure seals.</p>	 <p><i>Figure 15 – Bearing Assembly Removal</i></p>
---------------	---	--

5.3 Bearing Assembly Installation

The axle should be checked for size and condition before the bearing assemblies are reinstalled. Check the bearing manufacturer's service manual for steps and procedures to be taken in checking the axle. Any undesirable conditions such as upset ends, high spots or blemishes should be corrected.

- 5.3.1 To install a bearing assembly on an axle; attach the Guide Tube to the end of the axle with the cap screws provided (Figure 16).

Note - If many bearing assemblies are to be installed, at least two Guide Tubes should be used to facilitate a more efficient production.

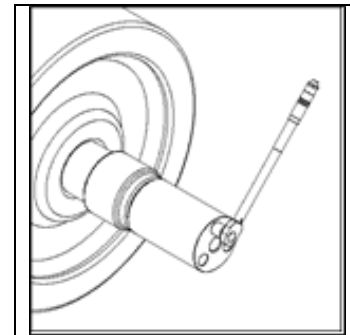

Figure 16 – Guide Tube Attachment

- 5.3.2 Thread the Installing Adaptor into the Guide Tube (Figure 17).

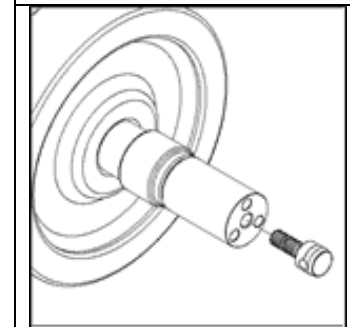

Figure 17 – Installing Adaptor

- 5.3.3 Coat the bearing seats of the axle with castor oil, heavy mineral oil, a Molykote and oil mixture, or as directed by the bearing manufacturer (Figure 18).

NOTE: DO NOT USE WHITE LEAD. Lead compounds act as an oxidation catalyst in lubricating greases.

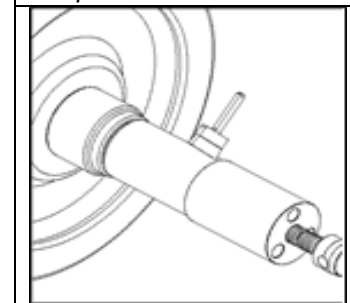

Figure 18 – Lubricate Bearing Seats

- 5.3.4 Slip the bearing assembly on the Guide Tube. The seal wear ring should be held in place to prevent it from riding out of the enclosure seal when the cardboard tube is ejected. A small lift is recommended for handling the large bearing assembly sizes (Figure 19).

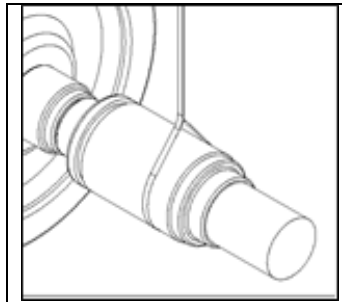

Figure 19 – Guide Tube Installation

- 5.3.5 Place the Installing Tube Adaptor Ring in position against the outer seal wear ring. The Installing Tube Adaptor Ring must be properly positioned on the Guide Tube to receive the installing Tube (Figure 20).

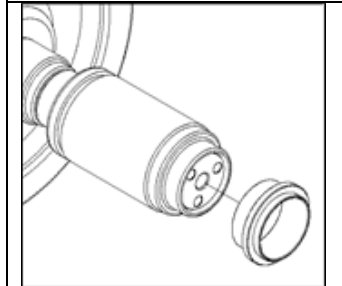

Figure 20 – Adaptor Ring Positioning

NOTE: ENSURE THE INSTALLING TUBE ADAPTOR RING IS NOT REVERSED!

- 5.3.6 If the Pulling Shoe Insert Adaptor has not been removed from the Pulling Shoe, remove it now. Bearing assembly installation cannot be completed when the Pulling Shoe Insert Adaptor is attached to the Pulling Shoe (Figure 21).

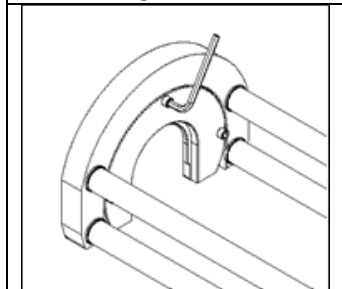

Figure 21 – Remove Adaptor

- 5.3.7 Place the Installing Tube Cradles between the lower arms of the Pulling Frame (Figure 22).

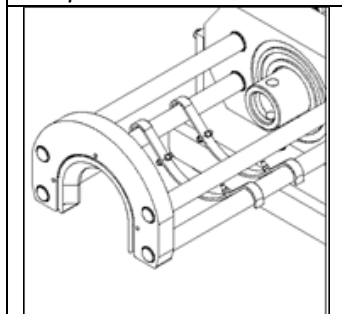

Figure 22 – Pulling Frame Placement

NOTE: THE INSTALLING TUBE MUST BE INSTALLED CORRECTLY! The tube end with the undercut will be visible if installed correctly.

- 5.3.8 Regulate the Installing Tube Cradle Adjusting screws to properly align the Installing Tube with the recess in the Hydraulic Cylinder Mounting Plate so that they will engage correctly (Figure 23). Normally this adjustment needs only to be made once and is not necessary each time a bearing assembly of the same size is to be installed.

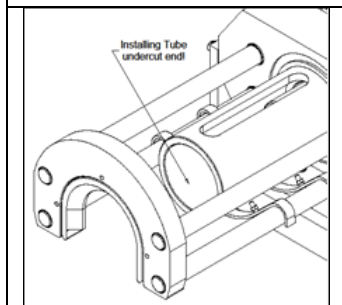

Figure 23 – Installing Tube Alignment

6.0 Maintenance



IMPORTANT:

- Use only good quality hydraulic fluid. **Do NOT** use brake fluid, transmission fluid, turbine oil, motor oil, alcohol, glycerine etc. Use of anything other than good quality hydraulic oil will void warranty and damage the pump, hose, and application. We recommend Durapac Hydraulic Oil or equivalent
- Equipment must only be serviced by a qualified hydraulic technician. For repair service, contact your local Durapac authorised service centre
- Tighten connections as needed. Use non-hardening pipe thread compound when servicing connections

Dirt, sand, etc. will quickly ruin any hydraulic system. Ensure that couplings are clean and free of foreign matter. After each use, clean couplings and attach dust caps.

Maintenance is required when wear or leakage is noticed. Periodically inspect all components to detect any problem that may require service and maintenance.

- 6.1 Check for loose connections and leaks.
- 6.2 Replace damaged parts immediately.
- 6.3 Do not exceed oil temperature above 60°C.
- 6.4 Keep all hydraulic components clean.
- 6.5 Use dust caps when puller is disconnected from the hose. Keep entire puller clean to prolong puller life.
- 6.6 Wipe thoroughly clean and store puller in the carry case (provided). Avoid temperature extremes.
- 6.7 Change hydraulic oil in your system as recommended in the pump instruction sheet.

7.0 Troubleshooting

Problem	Cause	Solution
Cylinder moves but does not maintain pressure	Leaking connection	<ul style="list-style-type: none"> • Clean, reseal with thread sealant and tighten connection
	Leaking cylinder seals	<ul style="list-style-type: none"> • Replace worn seals • Check for excessive contamination or wear • Replace contaminated fluid as necessary
	Malfunctioning pump/valve	<ul style="list-style-type: none"> • Repair or replace as necessary
Cylinder leaks hydraulic fluid	Worn or damaged seals	<ul style="list-style-type: none"> • Replace worn seals • Check for excessive contamination or wear • Replace contaminated fluid as necessary
	Loose connections	<ul style="list-style-type: none"> • Clean, reseal with thread sealant and tighten connection
Cylinder will not retract or retracts slower than normal	Closed pump release valve	<ul style="list-style-type: none"> • Open pump release valve
	Loose couplers	<ul style="list-style-type: none"> • Tighten couplers
	Blocked hydraulic lines	<ul style="list-style-type: none"> • Clean and flush lines
	Weak or broken retraction springs	<ul style="list-style-type: none"> • Send to a Durapac authorised service centre for repair
	Internally damaged cylinder	<ul style="list-style-type: none"> • Send to a Durapac authorised service centre for repair
	Pump reservoir too full	<ul style="list-style-type: none"> • Drain hydraulic fluid to correct level
Erratic Action	Air in system or pump cavitation	<ul style="list-style-type: none"> • Add fluid, bleed air and check for leaks
	External leakage	<ul style="list-style-type: none"> • Replace worn packings • Check for excessive contamination fluid as necessary • Replace contaminated fluid as necessary
	Sticking or binding cylinder	<ul style="list-style-type: none"> • Check for dirt or leaks • Check for bent, misaligned, worn parts or defective packings
Cylinder does not move	Loose couplers	<ul style="list-style-type: none"> • Tighten couplers
	Faulty coupler	<ul style="list-style-type: none"> • Verify that female coupler is not locked up (ball wedged into seat) • Replace both male and female couplers
	Improper valve position	<ul style="list-style-type: none"> • Close release valve or shift to new position
	Low or no hydraulic fluid in pump reservoir	<ul style="list-style-type: none"> • Fill and bleed the system
	Air-locked pump	<ul style="list-style-type: none"> • Add fluid, bleed air and check for leaks
	Load is above the capacity of the system	<ul style="list-style-type: none"> • Use the correct equipment

Problem	Cause	Solution
Cylinder extends only partially	Low or no hydraulic fluid in pump reservoir	<ul style="list-style-type: none"> • Fill and bleed the system
	Load is above the capacity of the system	<ul style="list-style-type: none"> • Use the correct equipment
	Sticking or binding cylinder	<ul style="list-style-type: none"> • Check for dirt or leaks • Check for bent, misaligned, worn parts or defective packings
Cylinder moves slower than normal	Loose couplers	<ul style="list-style-type: none"> • Tighten couplers
	Restricted hydraulic line or fitting	<ul style="list-style-type: none"> • Clean • Replace if damaged
	Low fluid level in pump reservoir	<ul style="list-style-type: none"> • Fill and bleed the system
	Leaking cylinder seals	<ul style="list-style-type: none"> • Replace worn seals • Check for excessive contamination or wear • Replace contaminated fluid as necessary

8.0 Parts Breakdown and List

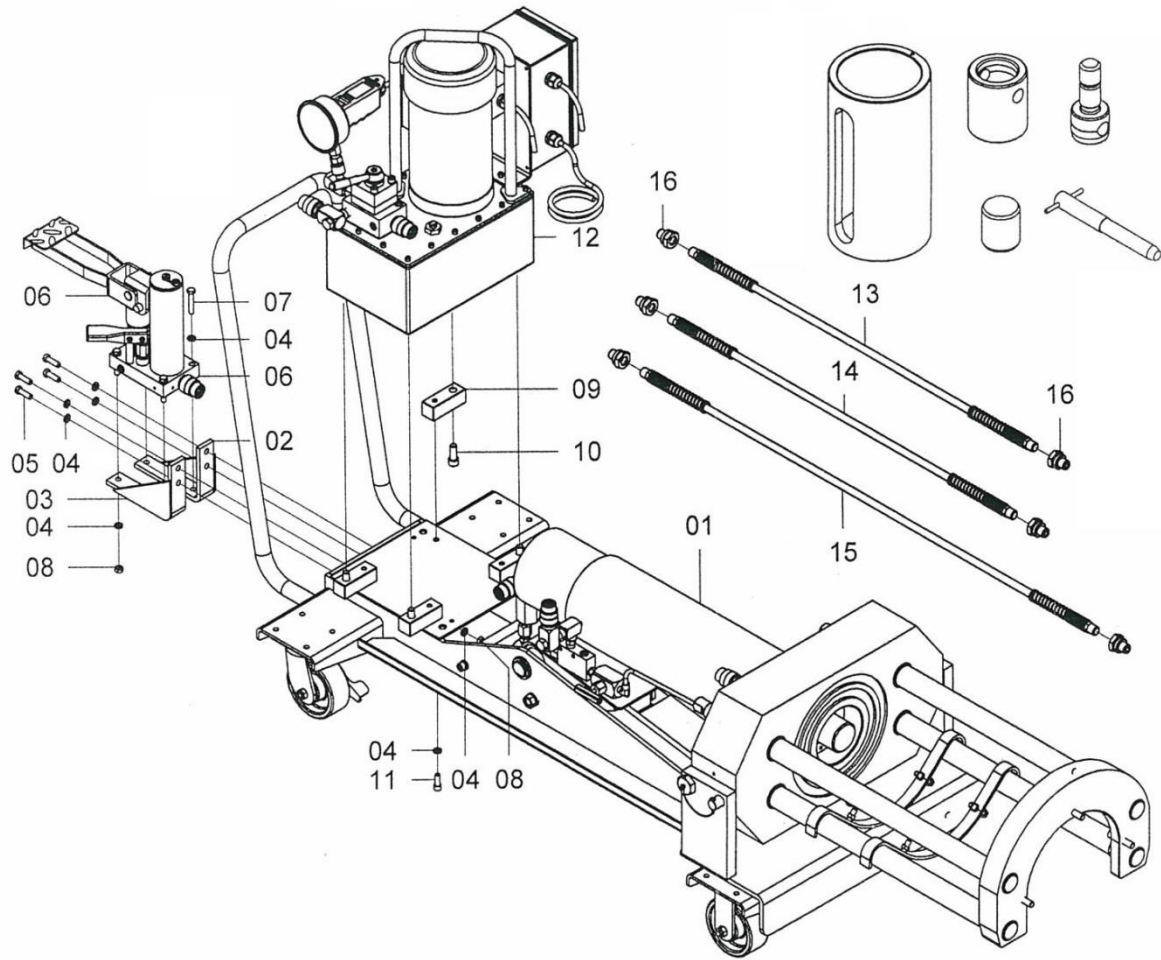

Item	Description	Part No.	Qty	Item	Description	Part No.	Qty
1	Puller & trolley	ZAL1770	1	9	Rear base foot	ZAL1955	4
2	Pump fixed suport A	ZAL1950	1	10	Cap screw	ZAL1956	4
3	Pump fixed suport B	ZAL1951	1	11	Cap screw	ZAL1880	4
4	Spring washer	ZAL1483	20	12	Electric power unit	PEM-1114-RB	1
5	Screw	ZAL1952	4	13	Hose	ZAL1766	1
6	Foot pump	ZAL1953	1	14	Hose - 0.9 mtr	ZAL1958	1
7	Screw	ZAL1954	4	15	Hose - 1.0 mtr	ZAL1959	1
8	Nut	ZAL1484	8	16	Quick coupler	ZAL1065	6

* see following pages for further breakdown

8.1 ZAL1770 - Puller and Trolley Assembly

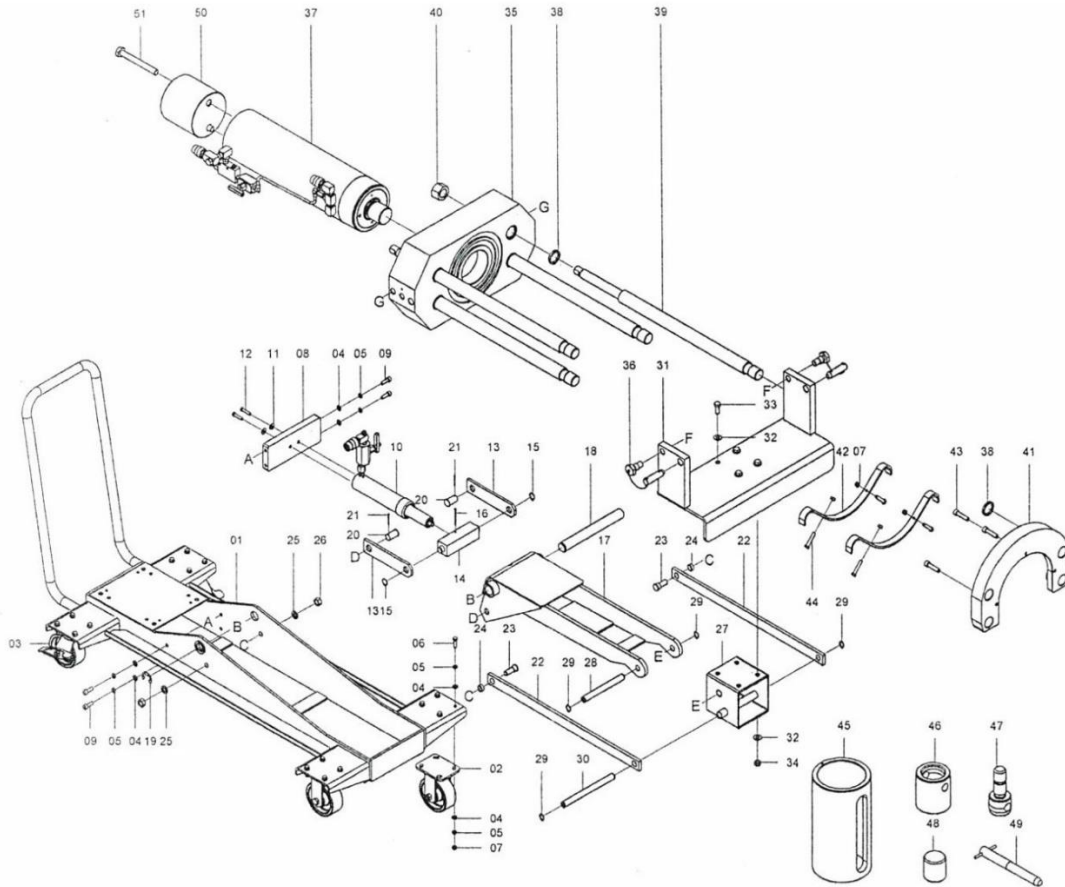

Item	Description	Part No.	Qty
1	Comp. hyd. block ass'y	ZAL1957	1
2	5" wheel	ZAL1960	2
3	5" locking wheel	ZAL1961	2
4	Washer	ZAL1763	36
5	Spring washer	ZAL1483	36
6	Screw	ZAL1952	16
7	Nut	ZAL1484	12
8	Cylinder mounting plate	ZAL1962	1
9	Screw	ZAL1963	4
10	Lifting cylinder	ZAL1964	1
11	Washer	ZAL1807	2
12	Screw	ZAL1965	2
13	Elevator arm connector	ZAL1966	2
14	Mandrel connector	ZAL1967	1
15	Retaining ring	ZAL1968	2
16	Cotter pin	ZAL1969	1
17	Elevator arm assembly	ZAL1970	1
18	Elevator arm shaft	ZAL1971	1
19	E-ring	ZAL1972	1
20	Connector pin	ZAL1973	2
21	Cotter pin	ZAL1974	2
22	Guide arm	ZAL1975	2
23	Guide arm bolt	ZAL1976	2
24	Guide arm bushing	ZAL1977	2
25	Spring washer	ZAL1712	2

Item	Description	Part No.	Qty
26	Nut	ZAL1757	2
27	Retaining block	ZAL1978	1
28	Pin	ZAL1979	1
29	Retaining ring	ZAL1777	4
30	Pin	ZAL1980	1
31	Mounting block saddle	ZAL1981	1
32	Washer	ZAL1982	8
33	Screw	ZAL1983	4
34	Nut	ZAL1785	4
35	Cylinder mounting block	ZAL1984	1
36	Fixed bolt	ZAL1985	2
37	Double acting cylinder	ZAL1986	1
38	Ring	ZAL1987	8
39	Push pulling pole	ZAL1988	4
40	Nut	ZAL1989	4
41	Pulling shoe	ZAL1990	1
42	Installing tube cradles	ZAL1991	2
43	Cap screw	ZAL1992	3
44	Screw	ZAL1954	4
45	Installing tube	ZAL1993	1
46	Guide block	ZAL1994	1
47	Installing adaptor	ZAL1995	1
48	Guide tube adaptor	ZAL1996	1
49	Connector pin	ZAL1997	1
50	Cylinder base	ZAL1998	1
51	Screw	ZAL1999	2

8.1.1 ZAL1964 – Lifting Cylinder Assembly

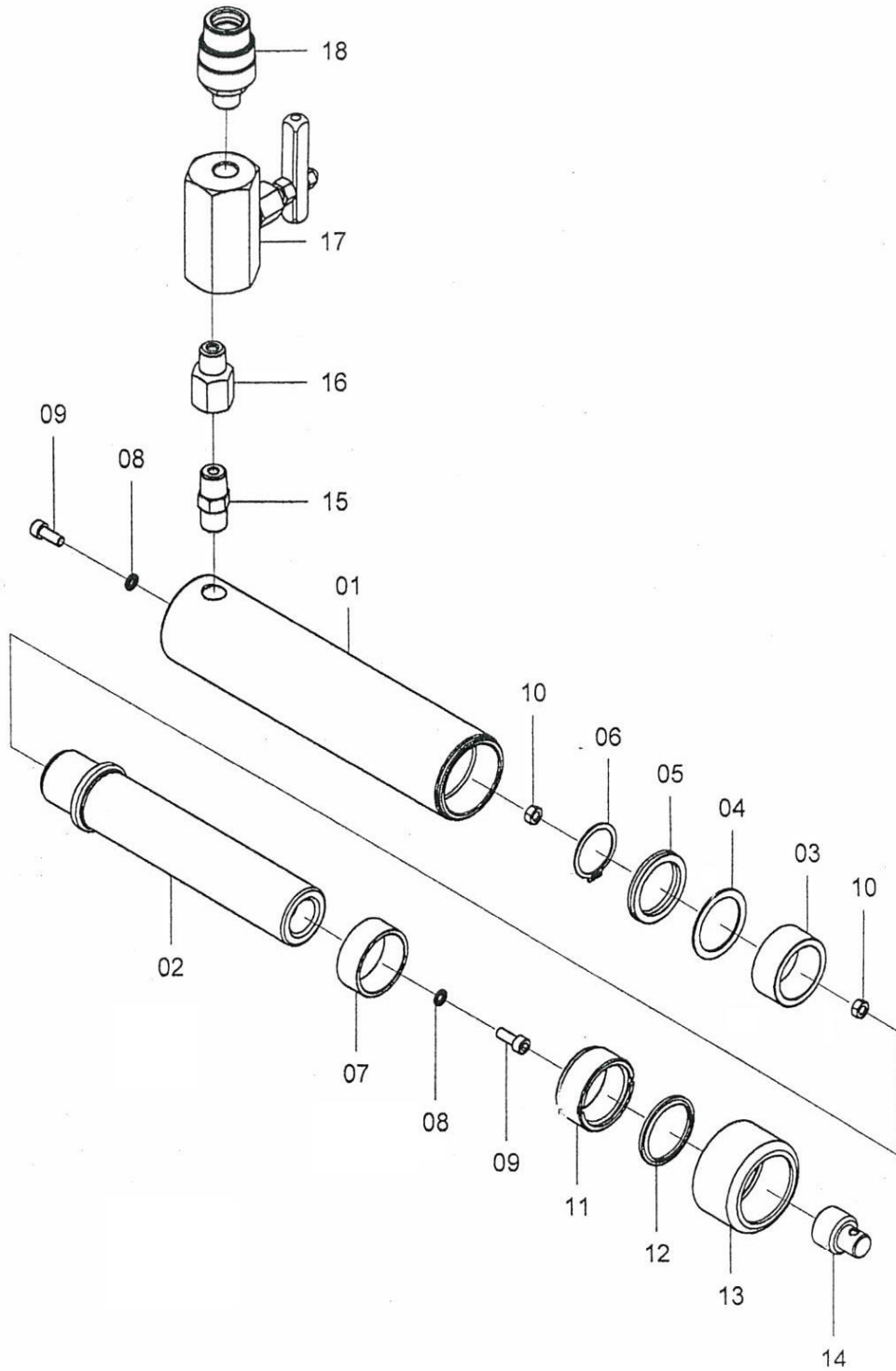

Item	Description	Part No.	Qty	Item	Description	Part No.	Qty
1	Cylinder base	ZAL2000	1	10	Nut	ZAL2007	2
2	Piston rod	ZAL2001	1	11	Fasten nut	ZAL2008	1
3	Brass bushing	ZAL2002	1	12	Wiper	ZAL2009	1
4	Back-up ring	ZAL2003	1	13	Cylinder sleeve	ZAL1469	1
5	U-cup seal	ZAL2004	1	14	Connector	ZAL2010	1
6	Retaining ring	ZAL1836	1	15	Hexagon nipple	ZAL1914	1
7	Stop ring	ZAL2005	1	16	Adaptor	ZAL1948	1
8	Gasket seal	ZAL1262	2	17	Relief valve	ZAL1915	1
9	Screw	ZAL2006	2	18	Quick coupler	ZAL1472	1

8.1.2 ZAL1986 – Double Acting Cylinder Assembly

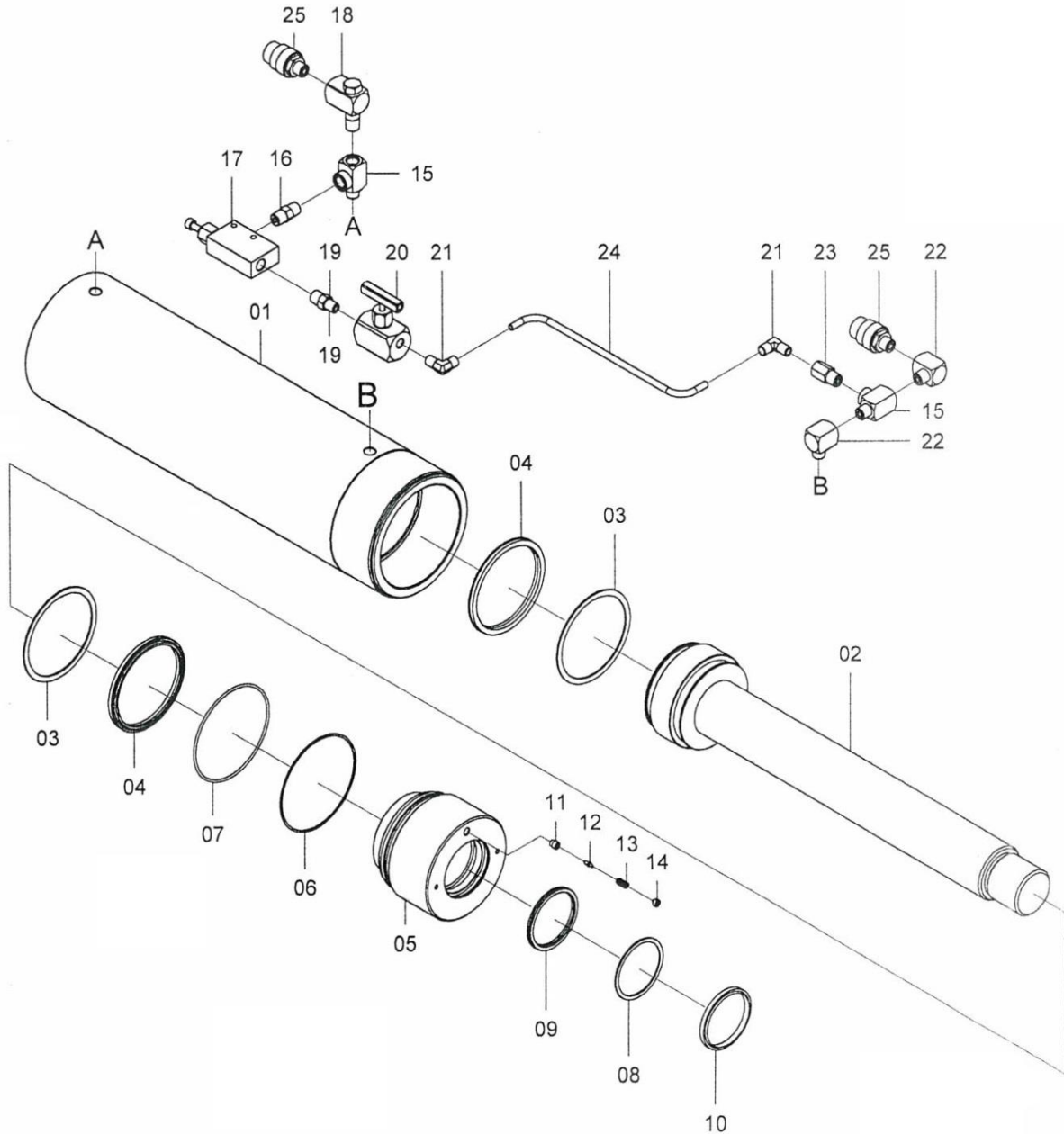

Item	Description	Part No.	Qty	Item	Description	Part No.	Qty
1	Cylinder base	ZAL2011	1	13	H.P. spring	ZAL1361	1
2	Piston rod	ZAL2012	1	14	Screw	ZAL2021	1
3	Back-up ring	ZAL2013	2	15	Tee	ZAL2022	2
4	U-cup seal	ZAL2014	2	16	Hexagon nipple	ZAL1914	1
5	Fasten nut	ZAL2015	1	17	Valve	ZAL2023	1
6	Back-up ring	ZAL2016	1	18	High flow swivel connector	ZAL1949	1
7	O-ring	ZAL2017	1	19	Reducing connector	ZAL2024	1
8	Back-up ring	ZAL2018	1	20	Needle valve	ZAL2025	1
9	U-cup seal	ZAL2019	1	21	Elbow	ZAL2026	2
10	Wiper	ZAL2020	1	22	Elbow	ZAL1913	2
11	Cone seat	ZAL1153	1	23	Adaptor	ZAL1651	1
12	Cone	ZAL1152	1	24	Tube assembly	ZAL2027	1
				25	Quick coupler	ZAL1472	2

8.2 ZAL1953 – Foot Pump Assembly

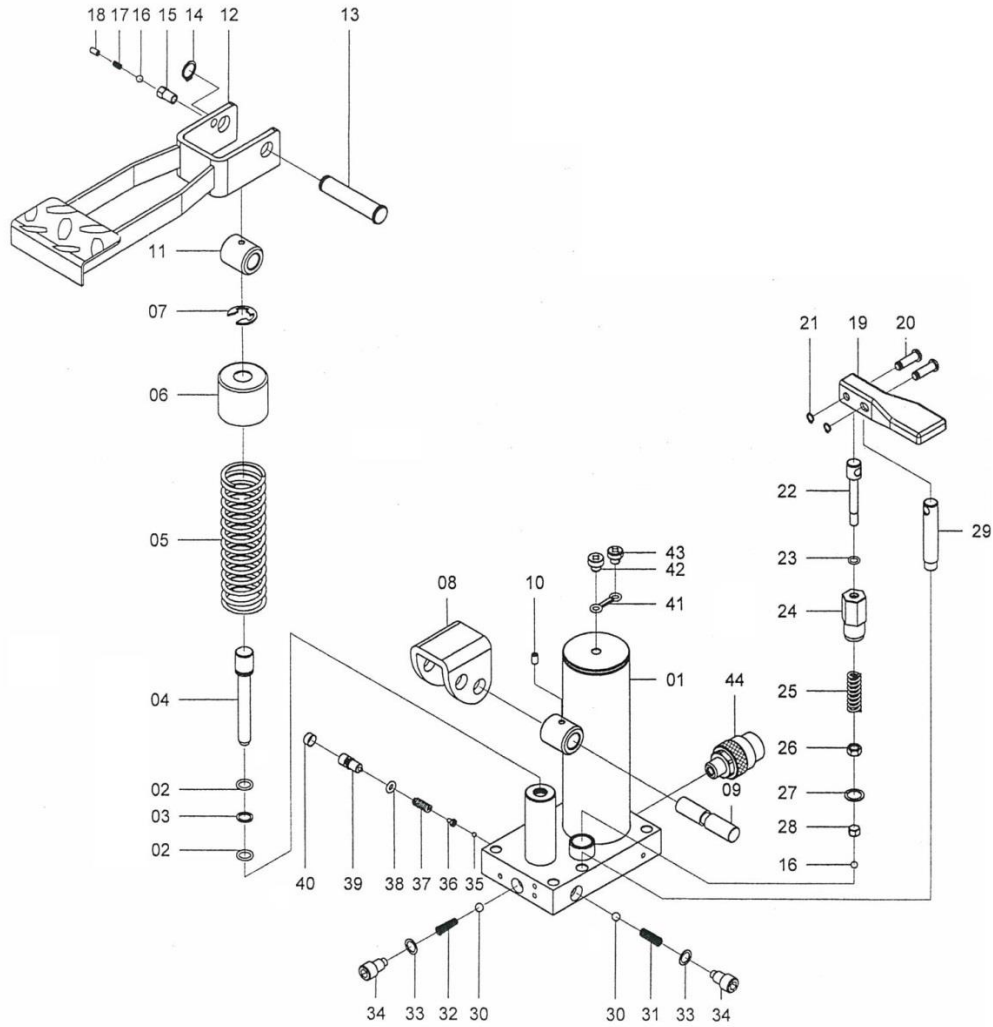

Item	Description	Part No.	Qty	Item	Description	Part No.	Qty
1	Cylinder with base	ZAL2028	1	23	O-ring	ZAL1273	1
2	O-ring	ZAL1272	2	24	Release valve	ZAL2045	1
3	Back-up ring	ZAL1209	1	25	Spring	ZAL2046	1
4	Piston	ZAL2029	1	26	Nut	ZAL2047	1
5	Spring	ZAL2030	1	27	Brass washer	ZAL2048	1
6	Spring cover	ZAL2031	1	28	Ball guider	ZAL2049	1
7	E-ring	ZAL2032	1	29	Support bar	ZAL2050	1
8	Pedal connector	ZAL2033	1	30	Steel ball	ZAL1368	2
9	Pin	ZAL2034	1	31	Long separator spring	ZAL5051	1
10	Screw	ZAL1826	1	32	Short separator spring	ZAL5052	1
11	Bushing	ZAL2035	1	33	Brass washer	ZAL1340	2
12	Pedal	ZAL2036	1	34	Valve cover screw	ZAL1286	2
13	Pedal pin	ZAL2037	1	35	Steel ball	ZAL1370	1
14	Snap ring	ZAL2038	1	36	Spring end cap	ZAL1096	1
15	Screw	ZAL2039	1	37	Spring	ZAL1346	1
16	Steel ball	ZAL1366	2	38	O-ring	ZAL1210	1
17	Spring	ZAL2040	1	39	Overload cover screw	ZAL1287	1
18	Screw	ZAL1290	1	40	Cap	ZAL1041	1
19	Release pedal	ZAL2041	1	41	O-ring	ZAL1216	1
20	Pin	ZAL2042	2	42	Air screw	ZAL1285	1
21	Snap ring	ZAL2043	2	43	Vent screw	ZAL1013	1
22	Release stem	ZAL2044	1	44	Quick coupler	ZAL1472	1

8.3 PEM-1114-RB –Electric Power Unit (parts list next page)

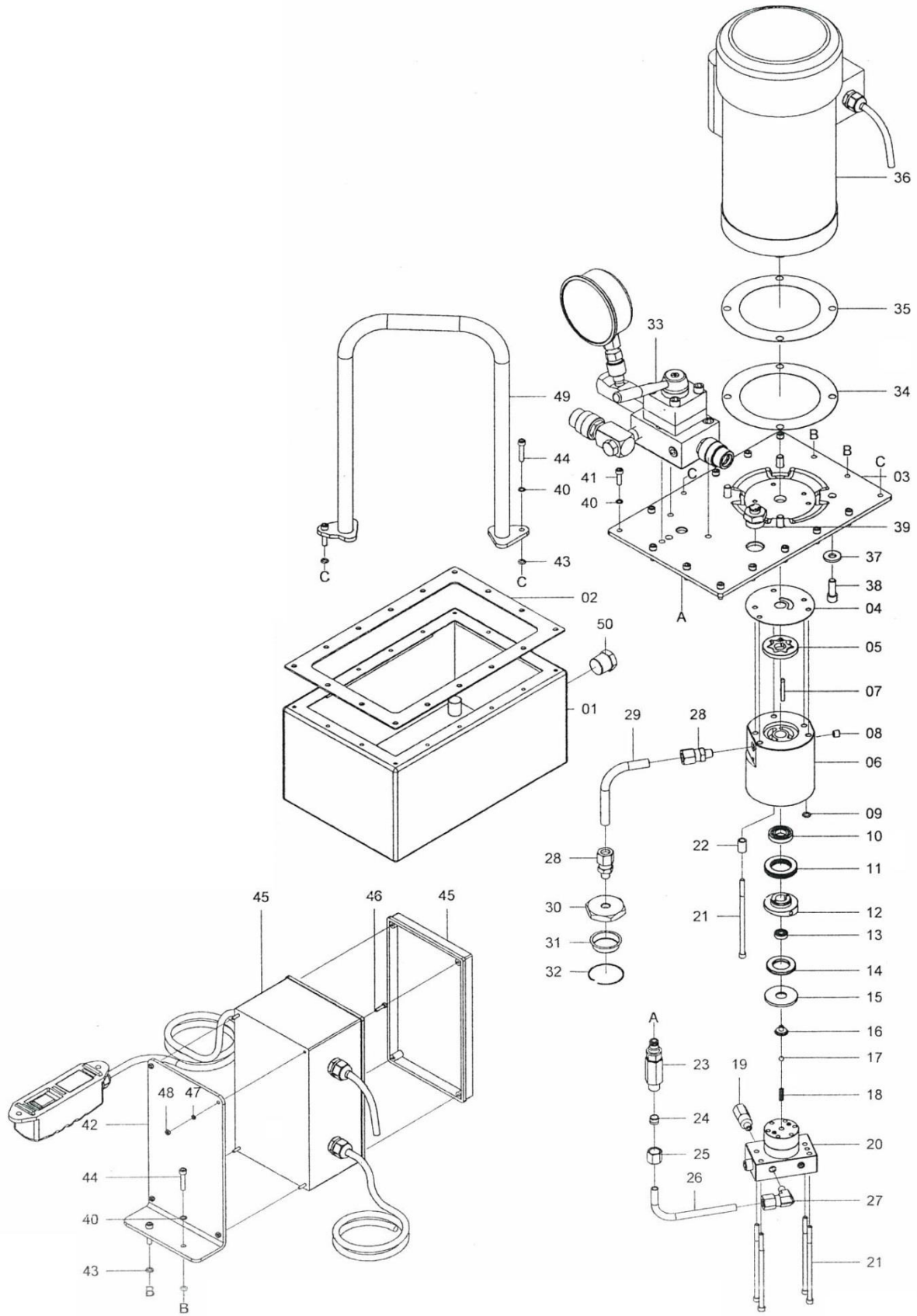

8.3.1 PEM-1114-RB Parts List

Item	Description	Part No.	Qty	Item	Description	Part No.	Qty
1	Reservoir	ZAL1846	1	26	Oil line tube	ZAL1868	1
2	Reservoir gasket	ZAL1847	1	27	Male elbow	ZAL1869	1
3	Reservoir cover	ZAL2053	1	28	Male connector	ZAL1870	2
4	Wear plate	ZAL1849	1	29	Intake tube	ZAL1871	1
5	Gerotor set	ZAL1850	1	30	Filter nut	ZAL1872	1
6	Pump body	ZAL1851	1	31	Filter	ZAL1873	1
7	Link bolt	ZAL1852	1	32	Spring ring	ZAL1874	1
8	Pipe plug	ZAL1853	1	33	Valve	ZAL2054	1
9	O-ring	ZAL1273	1	34	Aluminium washer	ZAL1876	1
10	Ball bearing	ZAL1854	1	35	Motor seal	ZAL1877	1
11	Fixing bearing	ZAL1855	1	36	Electric motor	ZAL1878	1
12	Angle plate	ZAL1856	1	37	Washer	ZAL1879	4
13	Ball bearing	ZAL1857	1	38	Cap screw	ZAL1880	4
14	Bearing	ZAL1858	1	39	Breather assembly	ZAL1881	1
15	Top plate	ZAL1859	1	40	Washer	ZAL1883	16
16	Top plate bearing	ZAL1860	1	41	Screw	ZAL1884	12
17	Steel ball	ZAL1366	1	42	Fixed plate	ZAL1885	1
18	Spring	ZAL1745	1	43	O-ring	ZAL1522	4
19	Relief valve assembly	ZAL1861	1	44	Screw	ZAL1886	4
20	High pressure pump ass'y	ZAL1862	1	45	Electric plate box	ZAL2055	1
21	Cap screw	ZAL1863	5	46	Cap screw	ZAL1888	4
22	Spacer	ZAL1864	1	47	Spring washer	ZAL1533	4
23	Valve connector	ZAL1865	1	48	Nut	ZAL1320	4
24	Ferrule sleeve	ZAL1866	1	49	Handle	ZAL1889	1
25	Nut	ZAL1867	1	50	Set screw	ZAL1890	1

8.3.1.1 ZAL2054 – Valve Assembly

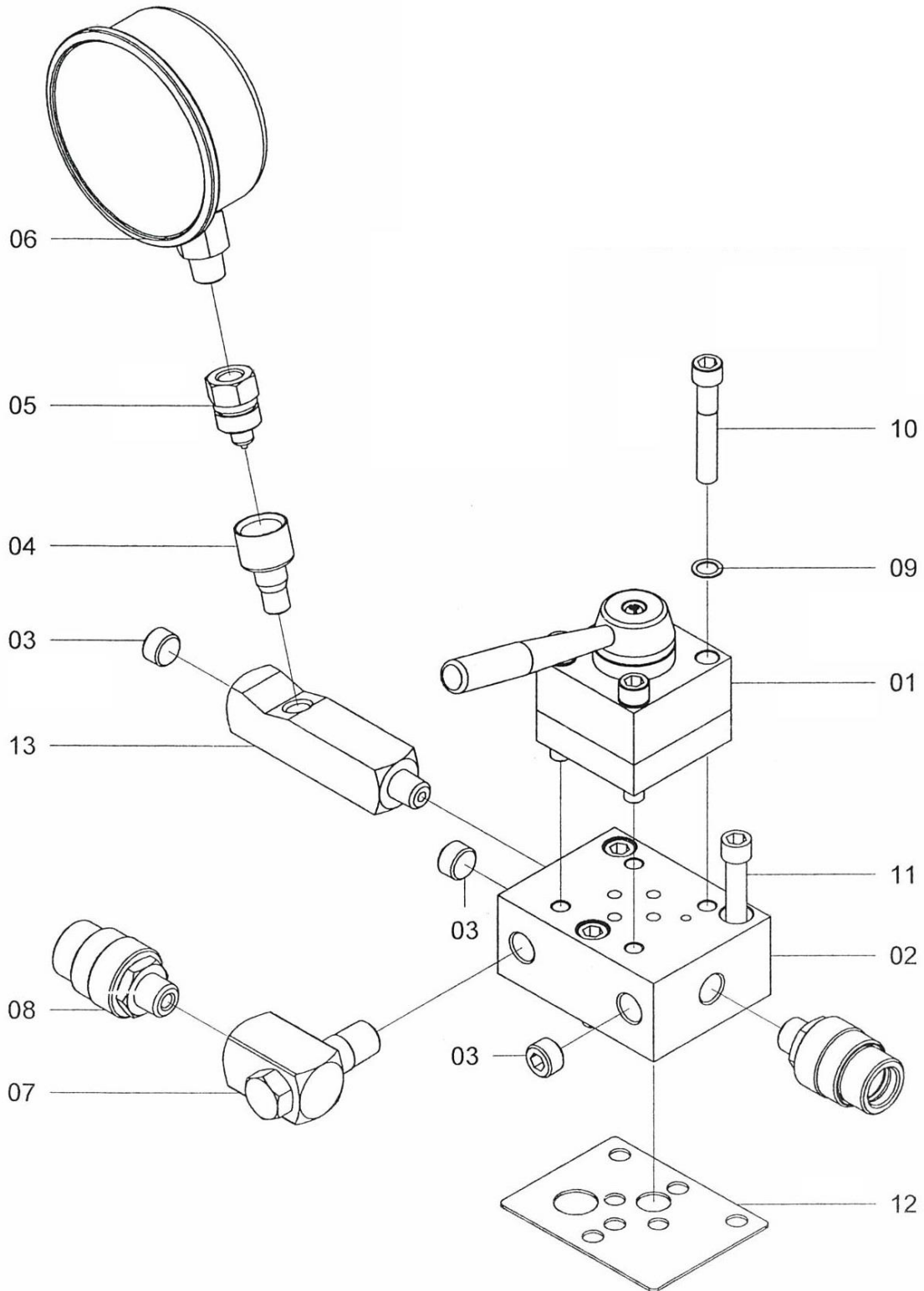

Item	Description	Part No.	Qty
1	4 way valve	ZAL1038	1
2	Valve body	ZAL2056	1
3	Pipe plug	ZAL1427	3
4	Quick coupler	ZAL1487	1
5	Quick coupler	ZAL1488	1
6	Gauge	ZAL2057	1

Item	Description	Part No.	Qty
7	High flow swivel connector	ZAL1949	1
8	Quick coupler	ZAL1472	2
9	Copper washer	ZAL1357	4
10	Cap screw	ZAL1714	4
11	Cap screw	ZAL1322	3
12	Valve gasket	ZAL1255	1
13	Gauge adaptor	ZAL2058	1