

THE **HP-SERIES** PRESSES ARE IDEAL FOR WORKSHOP PRESSING JOBS SUCH AS THE INSTALLATION OR REMOVAL OF BEARINGS AND GEARS OR OTHER PRESS FIT PARTS.

All models feature a manual pump, moveable work head and force gauge. 30 – 100 ton models also include V-blocks and an air/hydraulic pump with foot switch actuation.

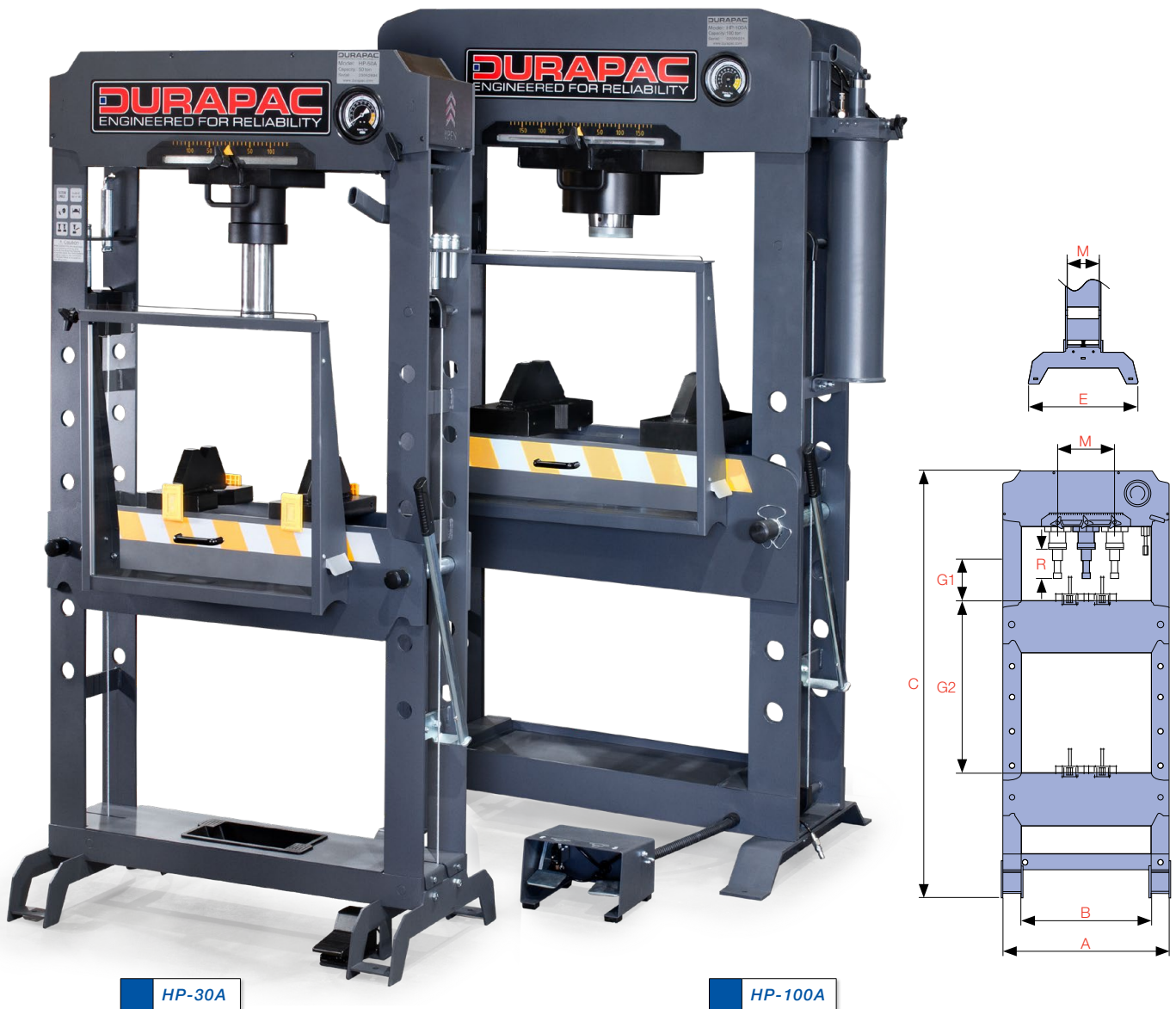

Model Number	Capacity (ton)	Hyd. Stroke (mm)	Screw Adjust (mm)	Pump Type	Pressure Rating (bar)	Air Pressure Range (bar)	Net Weight (kg)
HP-10	10	152	N/A	Manual	700	N/A	53
HP-30A	30	145	75	Air/Hyd. and Manual	N/A	9-12	244
HP-50A	50	145	75	Air/Hyd. and Manual	N/A	9-12	283
HP-100A	100	300	N/A	Air/Hyd. and Manual	N/A	9-12	719

ROLLING HEAD

to allow for side to side movement

FORCE GAUGE

in metric ton and bar

BED HEIGHT ADJUSTMENT

using a wire rope winch allows for vertical adjustment of bed

MANUAL PUMP

for precision adjustment

SAFETY SCREEN*

for impact protection

V BLOCKS*

included as standard

TOOL TRAY

for storage

PIN SET

supplied with HP-30A and HP-50A. Diameters: 30, 25, 22, 20, 18, 16, 12 & 10 mm

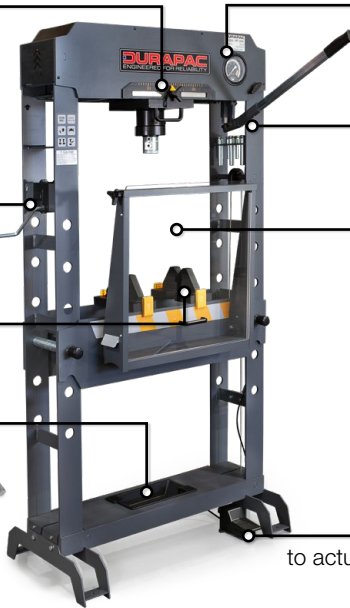

FOOT SWITCH*

to actuate the air/hydraulic pump



CAPACITY

10 - 100 ton

OPERATION

Air/Hydraulic & Manual

HP-50A

HP-10 standard accessories

10 TON HYDRAULIC CYLINDER

with 152 mm stroke

PRESS PLATE SET

and bushing allows for greater pressing flexibility

PRESS BED

has multiple working positions

2 SPEED HAND PUMP

With force gauge and 2 metre hose set



HP-10

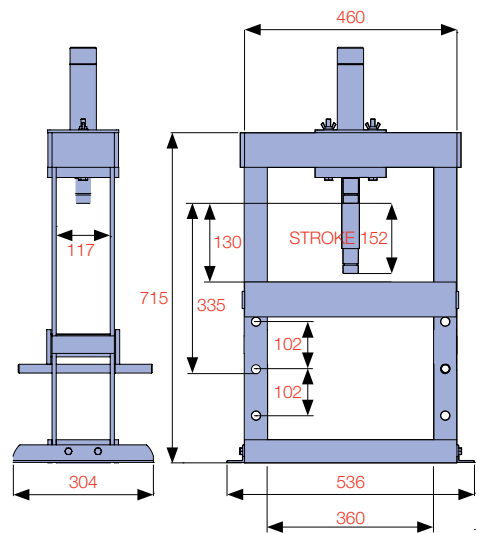
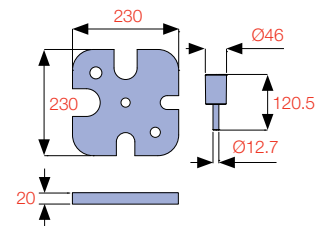

A (mm)	B (mm)	C (mm)	D (mm)	E (mm)	G1 (mm)	G2 (mm)	R Total Travel (mm)
REFER TO HP-10 DRAWING ABOVE							152
930	750	1,900	200	535	130	830	220
930	750	1,900	200	535	80	780	220
1,255	850	1,938	280	750	185	885	300

* Standard on all models except HP-10