

THE **DMS-SERIES** HYDRAULIC BOLT TENSIONERS ARE A MULTI-STAGE SPRING RETURN TENSIONER, DESIGNED TO FIT INTO COMPACT APPLICATIONS ON GRADE 10.9 BOLTS.

They feature a ratchet wind down for the change bushing, nut turning sleeve and are nickel coated for longevity.



CAPACITY

200 - 2,880 kN

BOLT RANGE

M20 - M72

MAXIMUM OPERATING PRESSURE

1,500 bar

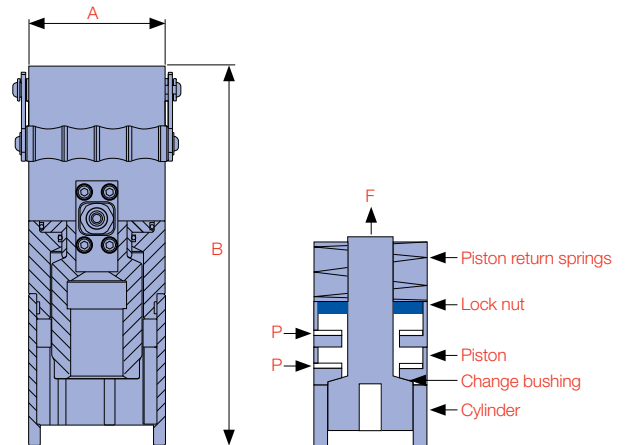

Model No.	Pre-load Force		Thread		A/F width		Diameter A		Height B	
	(kN)	(lbs)	(mm)	(in)	(mm)	(in)	(mm)	(in)	(mm)	(in)
DMS-M20	200	44,962	M20	3/4	30	1 1/4	47	1.9	169	6.7
DMS-M24	290	65,195	M24	7/8	36	1 7/16	60	2.4	200	7.9
DMS-M27	380	85,427	M27	1	41	1 5/8	65	2.6	210	8.3
DMS-M30	460	103,412	M30	1 1/8	46	1 13/16	72	2.8	204	8.0
DMS-M33	570	128,141	M33	1 1/4	50	2 13/16	79	3.1	216	8.5
DMS-M36	670	150,622	M36	1 3/8	55	2 3/16	83	3.3	250	9.8
DMS-M39	800	179,847	M39	1 1/2	60	2 3/8	91	3.6	265	10.4
DMS-M42	920	206,824	M42	1 5/8	65	2 9/16	98	3.9	272	10.7
DMS-M45	1,080	242,794	M45	1 3/4	70	2 3/4	106	4.2	273	10.7
DMS-M48	1,220	274,267	M48	1 7/8	75	2 15/16	112	4.4	290	11.4
DMS-M52	1,450	325,973	M52	2	80	3 1/8	123	4.8	336	13.2
DMS-M56	1,680	377,679	M56	2 1/4	85	3 1/2	131	5.2	356	14.0
DMS-M64	2,210	496,828	M64	2 1/2	95	3 7/8	150	5.9	357	14.1
DMS-M72	2,880	647,450	M72	3	105	4 5/8	168	6.6	406	16.0