



THE **DLW-SERIES** HYDRAULIC LIFTING WEDGE IS THE PERFECT CHOICE FOR HEAVY EQUIPMENT LIFTING WITH MINIMAL CLEARANCE.

The innovative design makes the Lifting Wedges not only practical but also a perfect complement to high-tonnage skates.

The DLW-18S model boasts a self-contained hydraulic system, eliminating the need for hoses, couplers, or pumps.



DLW-18S

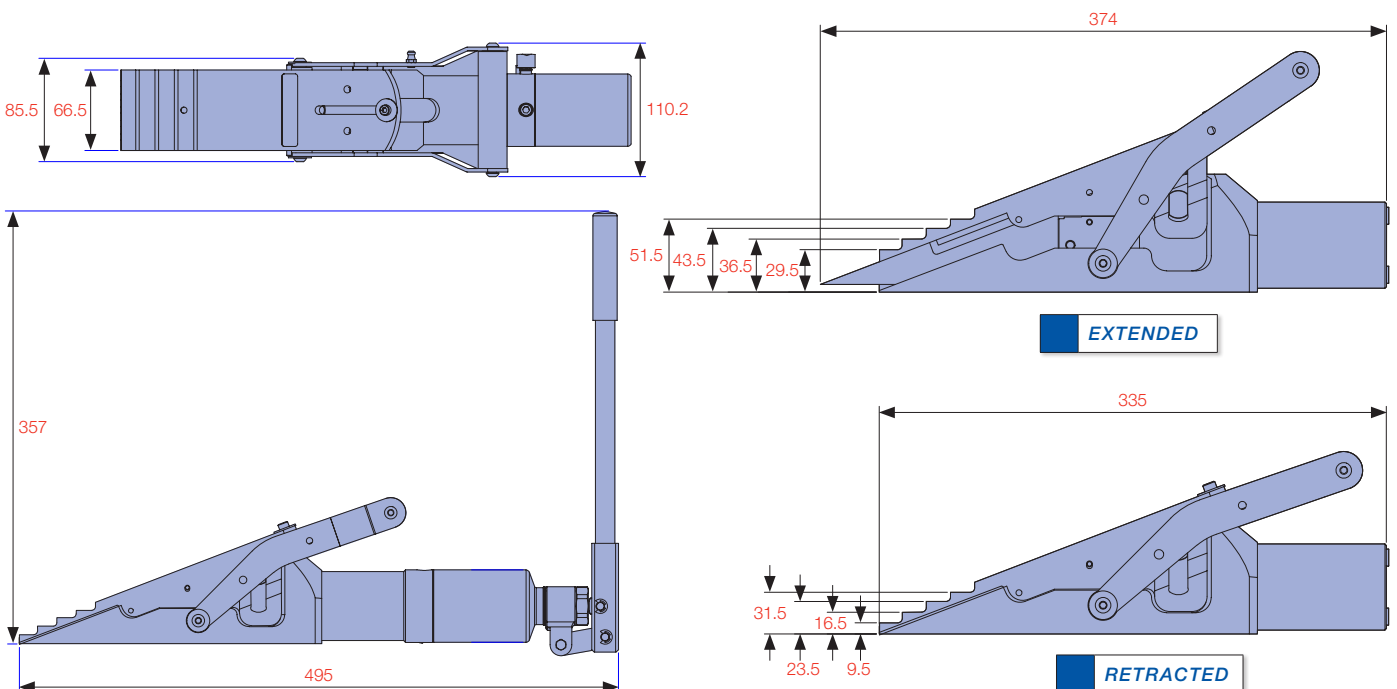

LINEAR ACTION

for smooth, straight movement

STEPS

offer 20 mm of vertical lift

ACCESS GAP

is only 9.5 mm

SINGLE ACTING SPRING RETURN CYLINDER

for easy retraction

SUPPLIED WITH A STEPPED AND SAFETY BLOCK



CAPACITY
18 ton

OPERATION
Self-contained & Remote

MAXIMUM OPERATING PRESSURE
700 bar

BOLTING SOLUTIONS



DLW-18

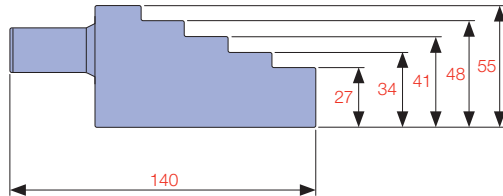

SAFETY BLOCK

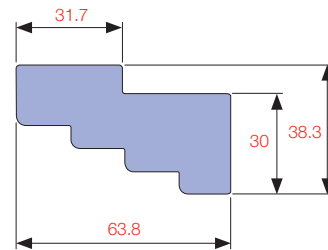

STEPPED BLOCK

Model No.	Operation	Wedgehead	Safety Block	Stepped Block	Hex Key & Screw	Handle Rod	Carry Case	Weight (kg)
DLW-18	Remote	18 ton	1	1	1	-	-	8.5
DLW-18S	Self-contained	18 ton	1	1	1	1	1	12.0