

POWERDRIVE

THE **SDN-SERIES** JACK IS AN ERGONOMICALLY DESIGNED PORTABLE JACKING SYSTEM THAT IS EASILY WHEELED AROUND A JOB SITE.

This unit is designed to lift heavy mining vehicles. It can be used on any hard surface (maintenance bays & workshops) and is easily transported by ute to site. The wheeled chassis has an ergonomically designed handle system which is adjustable, making it easy to move around by one person. The chassis frame is steel (not cast) for maximum durability and longevity. For safety, a 5 mtr remote control pendant is supplied to keep the operator out of the way of any possible hazards. Optional U-rings, tilt saddles and extensions are available.



Australian designed and built to meet AS/NZS 2693:2007 standard for vehicle jacks

SDN-10086-PD

Model Number	Jack Capacity			Cylinder Effective Area (cm ²)	A Collapsed Height (mm)**	B Base Plate Diameter (mm)	C Folded Length (mm)	D Jack Length (mm)	Stroke (mm)	Oil Tank Capacity (L)	Weight (kg)
	Metric (tonne)	US (ton)*	(kN)								
SDN-10068-PD	100	110	980	143	689	505	1,147	2,177	400	24	398
SDN-10086-PD	100	110	980	143	860	505	1,147	2,177	571	24	440
SDN-15068-PD	135	150	1,324	254	686	505	1,147	2,177	400	24	476
SDN-15096-PD	135	150	1,324	254	975	520	1,154	2,184	685	24	560
SDN-20068-PD	181	200	1,781	254	686	505	1,147	2,177	400	24	476
SDN-20096-PD	181	200	1,781	254	975	520	1,154	2,184	685	24	560

A non-POWERDRIVE option is also available – to order, use jack model number without “-PD” suffix (eg. SDL-10068)

* Nominal Cylinder Capacity in ton - see kN values for actual capacity. ** Includes load cap height of 22 mm

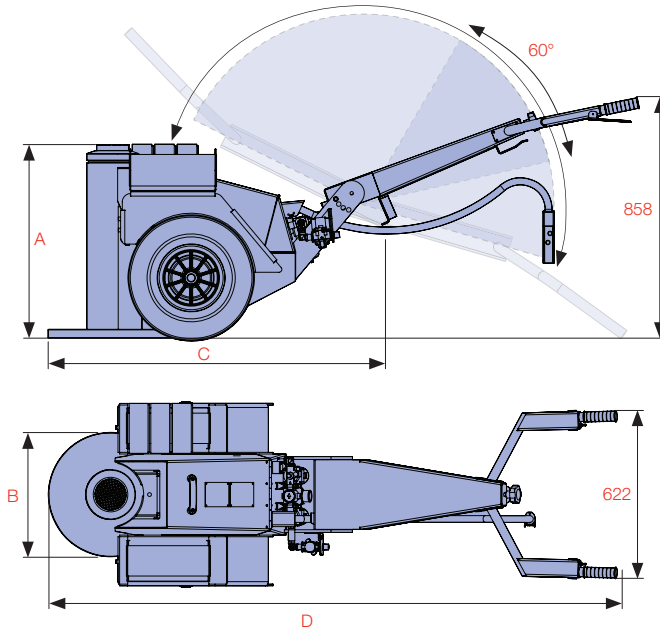

A
SPECIALTY LIFTING SYSTEMS

SERRATED STEEL LOAD CAP

included as standard

U-RINGS

for mechanical load support (optional)

U-RINGS HOLDER

for storage of U-ring saddles

LIFTING POINTS

allows easy forklift access

HIGH STRENGTH STEEL BASE PLATE

resists deformation

INDEPENDENT DEADMAN SWITCHES[#]

for easy manoeuvring and safety

TILT ADJUSTABLE HANDLE

for ease of manoeuvring and compact storage

THREE POSITION TOGGLE[#]

F (Forward)
 N (Neutral)
 R (Reverse)

ALUMINIUM REMOTE PENDANT

with mounted lock and unlock indicators & 5 M hose for added safety

TYRES WITH ALLOY RIMS

heavy duty, polyurethane filled, puncture-proof, large rolling diameter (450 mm)



i See Page 16 for SD-Accessories

[#] only available on -PD models

SD-ACCESSORIES

A

SPECIALTY LIFTING SYSTEMS



SDL WITH CUSTOM LOAD CAP

THE SD-ACCESSORIES ARE DESIGNED TO SUIT THE COMPACT **SAFE D LOCK** JACK AND IT'S EXTENDED FAMILY OF JACKS. THIS INCLUDES THE **POWERDRIVE**, EXTRA COMPACT, TALLEST, SLIMLINE & SDN-SERIES JACKS & DJS-SERIES JACK STANDS.

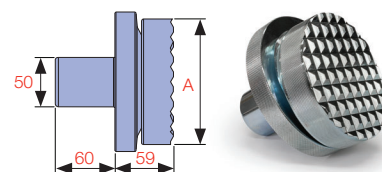

SDS-150/200N

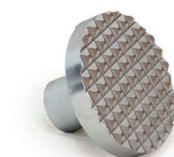

SDLC LOAD CAP

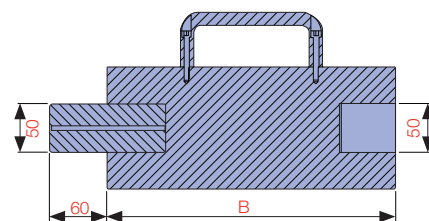

EXTENSION 100 - 500 mm

Model Number	Capacity (ton)	Description	A Diameter (mm)	B Height (mm)	Spigot Depth (mm)	Spigot Diameter (mm)	Weight (kg)	Suits Model(s)
SDE100-100	70/100	100 mm Extension	126	100	60	50	7	SDL/SDN 70 & 100 ton
SDE100-150	70/100	150 mm Extension	126	150	60	50	7	
SDE100-200	70/100	200 mm Extension	126	200	60	50	7	
SDE100-300	70/100	300 mm Extension	126	300	60	50	13	
SDE100-400	70/100	400 mm Extension	126	400	60	50	13	
SDLC-100	70/100	Serrated Steel Load Cap*	112	22	60	50	3	
SDS-100N	70/100	Serrated Tilt Saddle	108	50	60	50	5	SDL/SDN/DJS 150 ton
SDE150-150	150	150 mm Extension	126	150	60	50	7	
SDE150-200	150	200 mm Extension	126	200	60	50	7	
SDE150-250	150	250 mm Extension	126	250	60	50	7	
SDE150-300	150	300 mm Extension	126	300	60	50	13	
SDE150-350	150	350 mm Extension	126	350	60	50	13	
SDLC-150	150	Serrated Steel Load Cap*	126	22	60	50	3	SDL/SDN/DJS 150 & 200 ton
SDS-150/200N	150/200	Serrated Tilt Saddle	126	59	60	50	5	
SDE200-100	200	100 mm Extension	141	100	60	50	8	SDL/SDN/DJS 200 ton
SDE200-150	200	150 mm Extension	141	150	60	50	8	
SDE200-200	200	200 mm Extension	141	200	60	50	15	
SDE200-300	200	300 mm Extension	141	300	60	50	15	
SDE200-400	200	400 mm Extension	141	400	60	50	15	
SDE200-500	200	500 mm Extension	141	500	60	50	15	
SDLC-200	200	Serrated Steel Load Cap*	126	22	60	50	4	

* Supplied as standard

Custom load caps are available - consult Durapac



WARNING...
Do not stack extensions

SERRATED STEEL LOAD CAP

included as standard



CARRY HANDLE INCLUDED

made from high strength aluminium

U-RINGS

for mechanical load support



Radius saddles available - consult Durapac

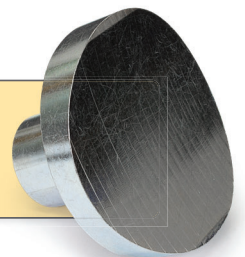

Model Number	Capacity (ton)	Description	Height (mm)	Weight (kg)	Suits Model(s)
SDNU-100-15	100	15 mm U-ring Saddle	15	0.6	SDN 100 ton
SDNU-100-25	100	25 mm U-ring Saddle	25	0.9	
SDNU-100-75	100	75 mm U-ring Saddle	75	2.8	
SDNU-100-100	100	100 mm U-ring Saddle	100	3.6	
SDNU-100-250	100	250 mm U-ring Saddle	250	9.0	
SDNU-200-15	150/200	15 mm U-ring Saddle	15	CONTACT DURAPAC	SDN 150 ton
SDNU-200-25	150/200	25 mm U-ring Saddle	25		
SDNU-200-75	150/200	75 mm U-ring Saddle	75		
SDNU-200-100	150/200	100 mm U-ring Saddle	100		
SDNU-200-250	150/200	250 mm U-ring Saddle	250		