



Instruction Manual

Air Hydraulic Jack

Model – ALJ60-3-175





This is a safety alert symbol. It is used to alert you to potential personal injury hazards. Obey all safety messages that follow this symbol to avoid injury or death

1.0 Product Information

DURAPAC – Air Hydraulic Jacks are engineered to meet Industrial Standards for Performance and Safety. The ALJ60-3-175 Air Hydraulic Jack is an ergonomically designed portable jacking system that is easily wheeled around a workshop.

This unit is designed for lifting of heavy vehicles. It can be used on any hard surface (maintenance bays and workshops) and is easily transported by ute or trailer. The wheeled carriage has an ergonomically designed handle system that is adjustable, making it easy to move around by a single person. The carriage frame is steel for maximum durability and longevity.

- Handle can be locked in 3 positions
- Built in safety valve to prevent overloading
- Automatic control of lowering speed for safety
- Hard chrome plated piston rods for long life
- 2 extension saddles included (75 mm & 45 mm)
- CE certified
- 3-year warranty
- Spare parts and service available Australia wide

Special skill, knowledge and training may be required for a specific task and the product may not be suitable for all jobs. The user must ultimately make the decision regarding suitability of the product for any given task and assume the responsibility of safety for all in the work area. Contact a Durapac representative if you are unsure of your jack's suitability for a particular application.

2.0 Receiving Instructions

It is recommended prior to use that an inspection be done by qualified personnel and that any missing or damaged parts, decals, warning/safety labels or signs are replaced with Durapac authorised replacement parts only. Any jack that appears to be damaged in any way, is worn, leaking or operates abnormally should be removed from service immediately until such time as repairs can be made. Any jack that has been or suspected to have been subject to a shock load should be removed from service immediately until inspected by a Durapac authorised service centre. Owners and operators of this equipment should be aware that the use and subsequent repair of this equipment may require specialised training and knowledge.

3.0 Safety

Save these instructions. For your safety, read and understand the information contained within. The owner and operator should understand this product and safe operating procedures before attempting to use this product. Instructions and safety information should be conveyed in the operator's native language before use of this product is authorised. Make certain that the operator thoroughly understands the inherent dangers associated with the use and misuse of the product. If any doubt exists as to the safe and proper use of this product as outlined in this factory authorised manual, remove from service immediately.

**DANGER:**

- To avoid personal injury keep hands and feet away from work area during operation
- **Do NOT** handle pressurised hoses. Escaping oil under pressure can penetrate the skin causing serious injury. If oil is injected under the skin, see a doctor immediately
- Stay clear of loads supported by hydraulics. A cylinder, when used as a load lifting device, should never be used as a load holding device. After the load has been raised or lowered, it must always be supported mechanically

**WARNING:**

- The system operating pressure must not exceed the pressure rating of the lowest rated component in the system. Install pressure gauges in the system to monitor operating pressure. It is your window to what is happening in the system
- Always wear appropriate personal protective equipment (PPE) when operating hydraulic equipment. The operator must take precaution against injury due to failure of the tool or work piece(s)
- **Do NOT** hold or stand directly in line with any hydraulic connections while pressurising
- **Do NOT** attempt to disconnect hydraulic connections under pressure. Release all line pressure before disconnecting hoses
- All personnel must be clear before lowering load or depressurising the system
- **Do NOT** attempt to lift a load weighing more than the capacity of the cylinder

**IMPORTANT:**

- If at any stage, the safety related decals become hard to read, these must be replaced
- Minimum age of the operator must be 18 years. The operator must have read and understood all instructions, safety issues, cautions and warnings before starting to operate the equipment. The operator is responsible for this activity towards other persons
- **Do NOT** lift hydraulic equipment by the hoses or couplers. Use the carrying handle or other means of safe transport
- Hydraulic equipment must only be serviced by a qualified hydraulic technician. For repair service, contact the Durapac authorised service centre in your area. To protect your warranty, use only high-quality hydraulic oil

**CAUTION:**

- **KEEP HYDRAULIC EQUIPMENT AWAY FROM FLAMES AND HEAT.** Hydraulic fluid can ignite and burn. Excessive heat will soften packings and seals, resulting in fluid leaks. Heat also weakens hose materials and packings. For optimum performance do not expose equipment to temperatures of 65°C (150°F) or higher. Protect all equipment from weld spatter
- No alteration should be made to this device

3.1 Jacks

- Stay clear of loads supported by hydraulics
- **Do** use a gauge or other load measuring instrument to verify load, where possible
- **Do NOT** exceed the rated capacity of the pump or any equipment in the system. Burst hazard exists if connection pressure exceeds rated pressure
- **Do NOT** set the relief valve to a higher pressure than the maximum rated pressure. Higher settings may result in equipment damage and/or personal injury
- **Do NOT** operate the system with bent or damaged couplers or damaged threads
- **Do NOT** subject the pump and its components to shock loads
- Use only Durapac approved accessories and components
- **Do NOT** overload equipment. Overloading can cause equipment failure and possible personal injury
- **BE SURE SETUP IS STABLE BEFORE LIFTING LOAD.** The jack should be placed on a flat surface that can support the load. **Avoid** situations where loads are not directly centred on the cylinder piston. Off-centre loads produce considerable strain on cylinder and pistons. In addition, the load may slip or fall, causing potentially dangerous results
- Ensure vehicle has suitable wheel chocks installed to prevent unplanned movement
- Distribute the load evenly across the entire load cap surface. Always use a load cap to protect the piston
- **Never** pressurise uncoupled couplers. Only use hydraulic equipment in a coupled system
- **Do NOT** drive or push the load off the jack. Lower jack and remove before moving the load
- Properly support the jack and jack bases
- Lift only dead weight loads

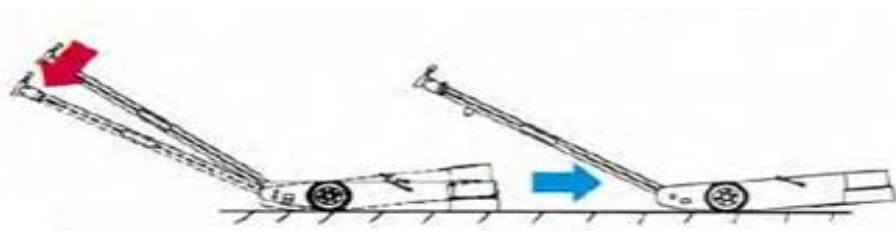


Figure 1 – Press handle down to move jack forward

3.2 Extensions

- Choose the tallest extension available that still allows suitable clearance under the truck jacking point

FAILURE TO HEED THESE WARNINGS MAY RESULT IN PERSONAL INJURY AS WELL AS PROPERTY DAMAGE.

4.0 Installation

- 4.1 Familiarise yourself with the specifications and illustrations in this owner’s manual. Know your jack, its limitations and how it operates before attempting to use. Refer to the specification chart below or if in doubt, contact a Durapac representative.

Specifications

Model	ALJ60-3-175
Capacity	60T / 40T / 20T
Working Air Pressure	8 - 12 bar
Min. Height	175 mm
Stroke (Stage 1)	82 mm @ 60T
Stroke (Stage 2)	81 mm @ 40T
Stroke (Stage 3)	84 mm @ 20T
Extension Height	75 mm + 45 mm
Max. Height Incl. Extensions	542 mm

Shipping

Net Weight	73 kg
Box 1	0.11 m ³ -- 73 kg (GW)
Box 2	0.04 m ³ -- 9 kg (GW)

Dimensions

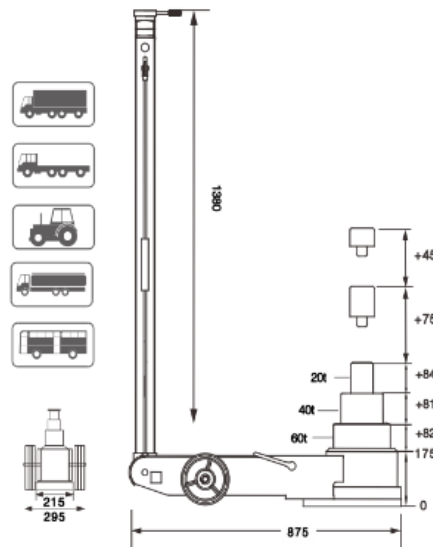


Figure 2 - Dimensions

- 4.2 Check all system fittings and connections to be sure they are tight and leak free.
 4.3 Jacks come filled with hydraulic oil.

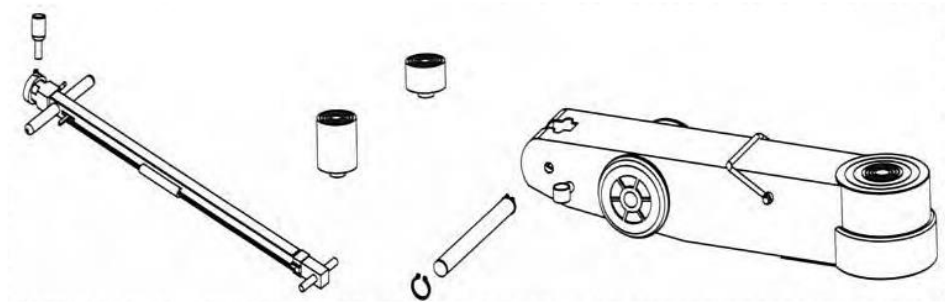
5.0 Assembly

Figure 3 - Components

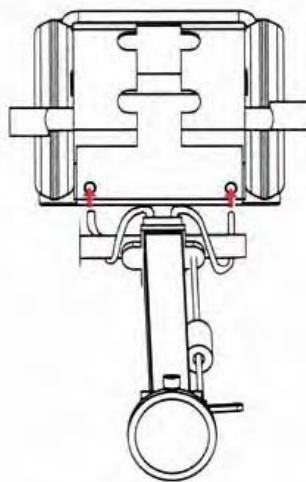


Figure 4 – Connect 2 x Air Tubes

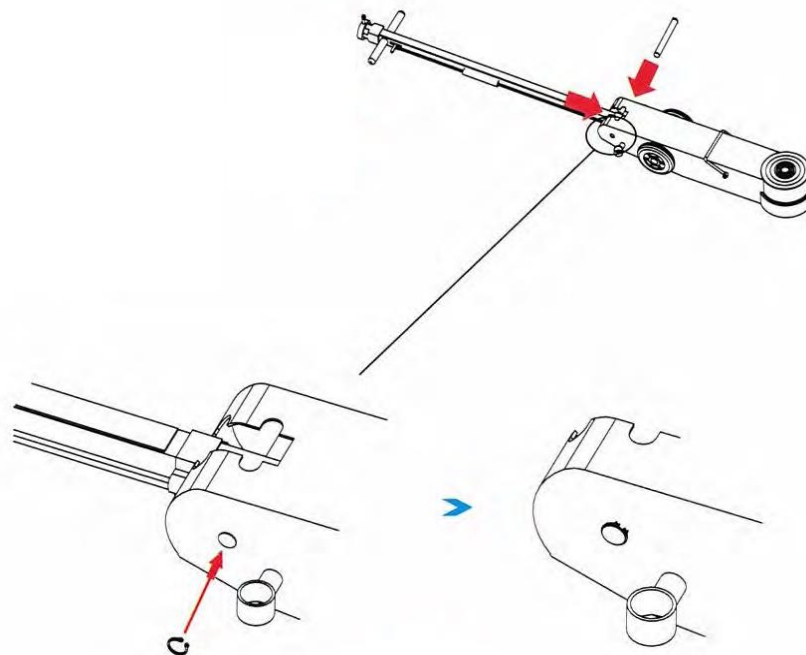


Figure 5 – Insert Pin to Connect Handle to Jack

6.0 Operation



IMPORTANT:

- Always use a flat, hard surface under the cylinder support plate
- Avoid off-centre loads which could damage the cylinder, cause loss of the load and possible serious injury or death
- Control the load at all times. **Do NOT** drop the load
- Cylinder gland nut/stop ring is designed to take the full load, to reduce cylinder wear, use less than the full stroke where possible
- Always monitor pressure, load or position using suitable equipment. Pressure may be monitored by means of the gauge. Correct application position can only be determined by the operator of the equipment
- **Do NOT** operate a pump that is disconnected from the application. If operated in this condition, the hose and connections will become pressurised. This increases the chance of a burst hazard. Damage may also occur to the pump and its components
- Fully retract the cylinder and protect the entire unit from external damage
- The jack must be perpendicular to the load; jacking on an angle can result in the jack slipping out and loss of load
- Use a jack with at least 10% more capacity than what is required
- **Do NOT** crawl or place any part of your body under any load at any time unless it is mechanically locked. Insert additional vehicle support stands if needed
- **Always** used the hardened removable load cap. **Do NOT** lift a load directly on the piston rod

6.1 Positioning the Handle

The jack's handle can be put in three different positions:

Lowered to position the jack under a low height vehicle.

Mid-range for easy manoeuvring around the workshop.

Upright for storage and transporting.

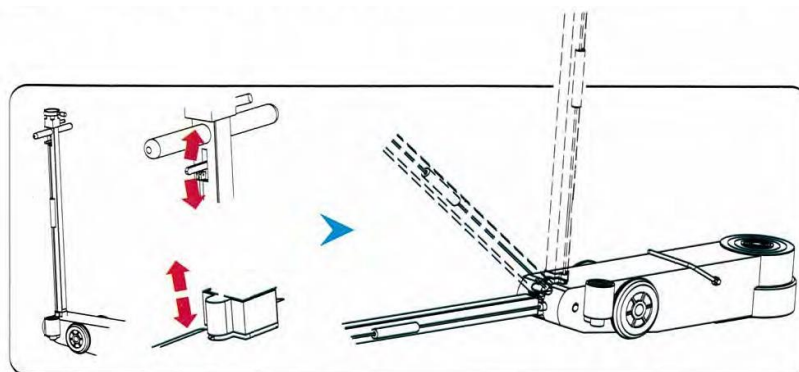


Figure 6 – Handle Positions

6.2 Positioning the Jack

⚠ The cylinder load cap should engage against a flat surface, parallel to the cylinder base.

6.2.1 Select the appropriate extension.

6.2.2 Position the jack under the load.

6.3 Advancing and Lowering the Load

6.3.1 Move the control valve handle to the UP position to advance the cylinder (Fig. 7). Once the load has been raised to the desired height, release the control valve handle.

6.3.2 Move the control valve handle to the DOWN position to retract the cylinder (Fig. 7). Once the load has been lowered to the desired height, release the control valve handle.

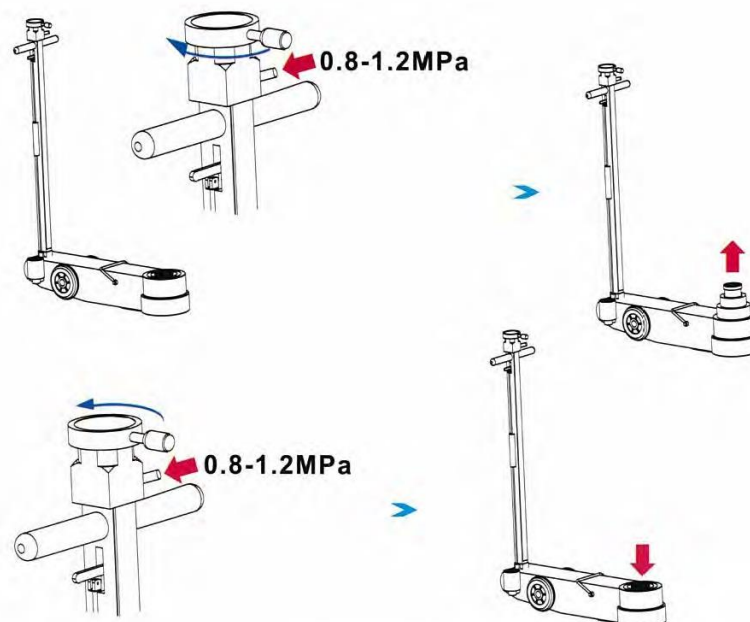


Figure 7 – Advancing & Lowering the Load

6.4 After Using the Jack

6.4.1 Fully retract the cylinder.

6.4.2 Disconnect the air supply.

6.5 Transporting the Jack

A forklift may be used to lift the jack onto a ute or trailer using the sling point.

7.0 Maintenance




IMPORTANT:

- Check oil level regularly
- Use only good quality hydraulic fluid. **Do NOT** use brake fluid, transmission fluid, turbine oil, motor oil, alcohol, glycerine etc. Use of anything other than good quality hydraulic oil will void warranty and damage the pump, hose, and application. We recommend Durapac Hydraulic Oil or equivalent
- Equipment must only be serviced by a qualified hydraulic technician. For repair service, contact your local Durapac authorised service centre
- Damage to hydraulic hoses may not be detected during visual inspections. For this reason, Durapac recommends that hydraulic hoses be replaced on a regular basis
- Tighten connections as needed. Use non-hardening pipe thread compound when servicing connections

Maintenance is required when wear or leakage is noticed. Periodically inspect all components to detect any problem that may require service and maintenance.

7.1 Changing Hydraulic Fluid

 For best results, change fluid once a year or every 300 hours of use

- 7.1.1 Pour used fluid into a sealable container.
- 7.1.2 Dispose of fluid in accordance with local regulations.

7.2 Storage

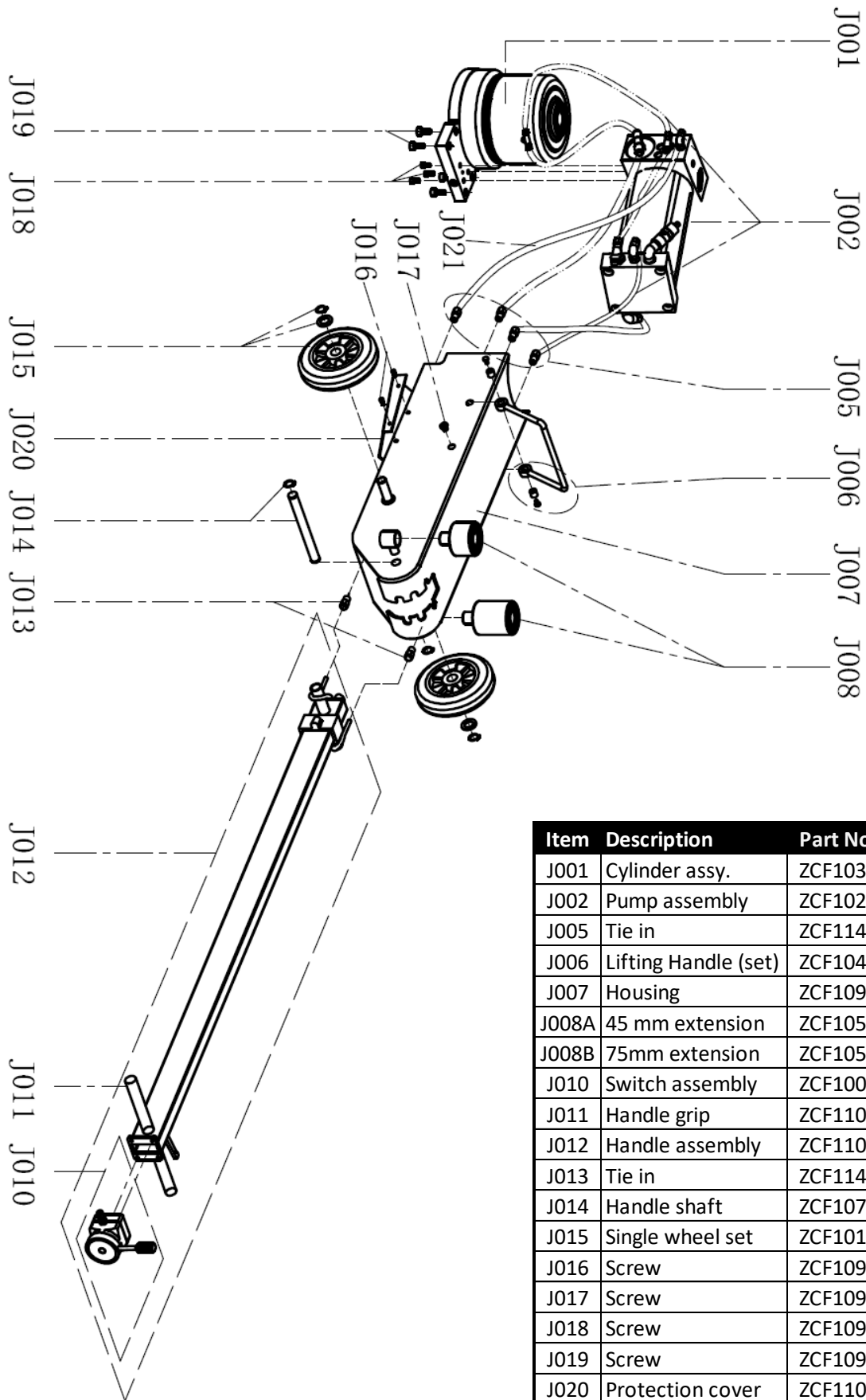
- 7.2.1 When not in use, depressurise and disconnect the hydraulic jack from the application.
- 7.2.2 Wipe clean thoroughly and store in a clean, dry environment. Avoid temperature extremes.
- 7.2.3 Shield jack with a protective cover.

8.0 Troubleshooting

Problem	Cause	Solution
Pump loses pressure	Leaking system components	<ul style="list-style-type: none"> • Repair or replace as necessary
Pump not delivering fluid	Low fluid level in reservoir	<ul style="list-style-type: none"> • Check fluid level
	Worn seats	<ul style="list-style-type: none"> • Repair seats • Replace pump body
Pump does not reach rated capacity	Low fluid level in reservoir	<ul style="list-style-type: none"> • Check fluid level
	Leaking system components	<ul style="list-style-type: none"> • Repair or replace as necessary
	Fluid leaking past inlet or outlet checks	<ul style="list-style-type: none"> • Repair inlet or outlet checks • Replace high pressure piston seal
Cylinder piston will not extend	Loose fittings	<ul style="list-style-type: none"> • Tighten couplers
	Low fluid level in pump reservoir	<ul style="list-style-type: none"> • Fill and bleed the system
	Leaking cylinder seals	<ul style="list-style-type: none"> • Replace worn seals. Look for excessive contamination or wear
Cylinder piston extends only partially	Low fluid level in pump reservoir	<ul style="list-style-type: none"> • Fill and bleed the system
	Load above capacity of system	<ul style="list-style-type: none"> • Use correct equipment
Cylinder piston extends slower than normal	Loose couplers	<ul style="list-style-type: none"> • Tighten couplers
	Restricted hydraulic line or fitting	<ul style="list-style-type: none"> • Clean and replace if damaged
	Pump not operating correctly	<ul style="list-style-type: none"> • Check pump’s operating instructions • Repair or replace as necessary
	Low fluid level in pump reservoir	<ul style="list-style-type: none"> • Fill and bleed the system
Cylinder does not hold pressure	Leaky connection	<ul style="list-style-type: none"> • Clean, reseal with thread sealant, and tighten connection
	Leaking cylinder seals	<ul style="list-style-type: none"> • Replace worn seals. Look for excessive contamination or wear. Replace contaminated fluid
	Pump or valve not operating correctly	<ul style="list-style-type: none"> • Repair or replace as necessary
Cylinder will not retract or retracts slower than normal	Closed pump release valve	<ul style="list-style-type: none"> • Open pump release valve
	Loose couplers	<ul style="list-style-type: none"> • Tighten couplers
	Blocked hydraulic lines	<ul style="list-style-type: none"> • Clean and flush lines
		<ul style="list-style-type: none"> • Send to a Durapac authorised service centre for repair
	Internally damaged cylinder	<ul style="list-style-type: none"> • Send to a Durapac authorised service centre for repair
	Pump reservoir too full	<ul style="list-style-type: none"> • Drain fluid to correct level

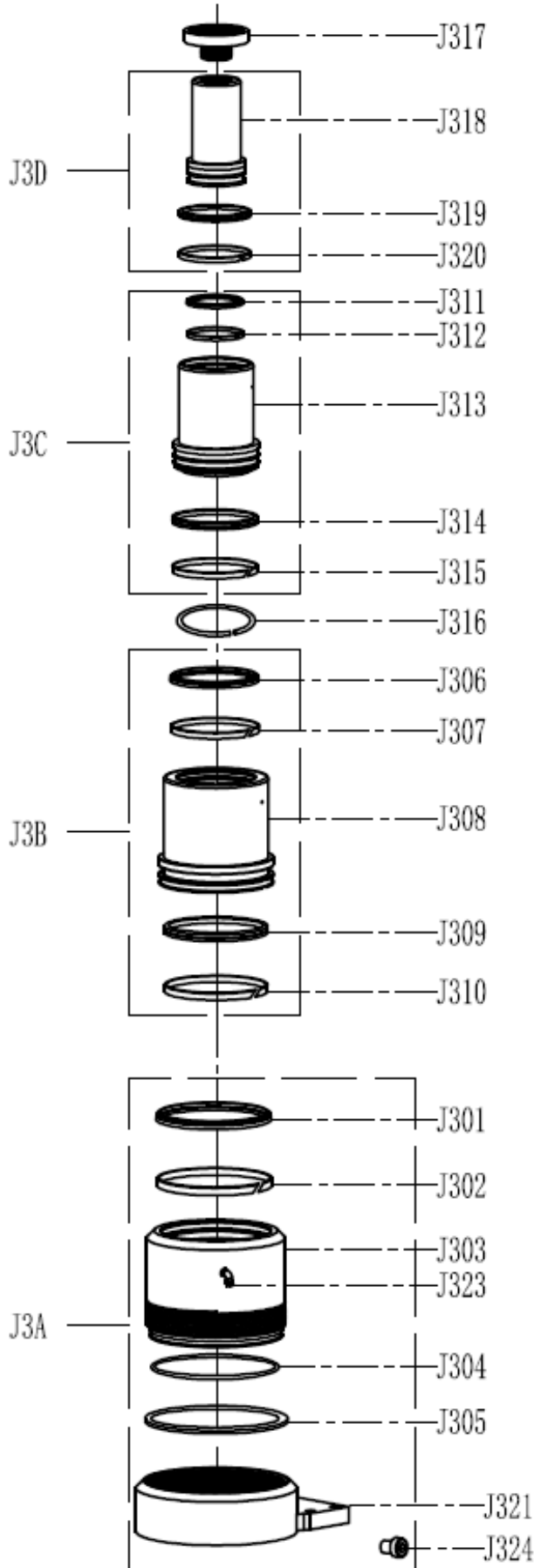
9.0 Parts Breakdown and List

9.1 Complete Assembly Parts Breakdown and List



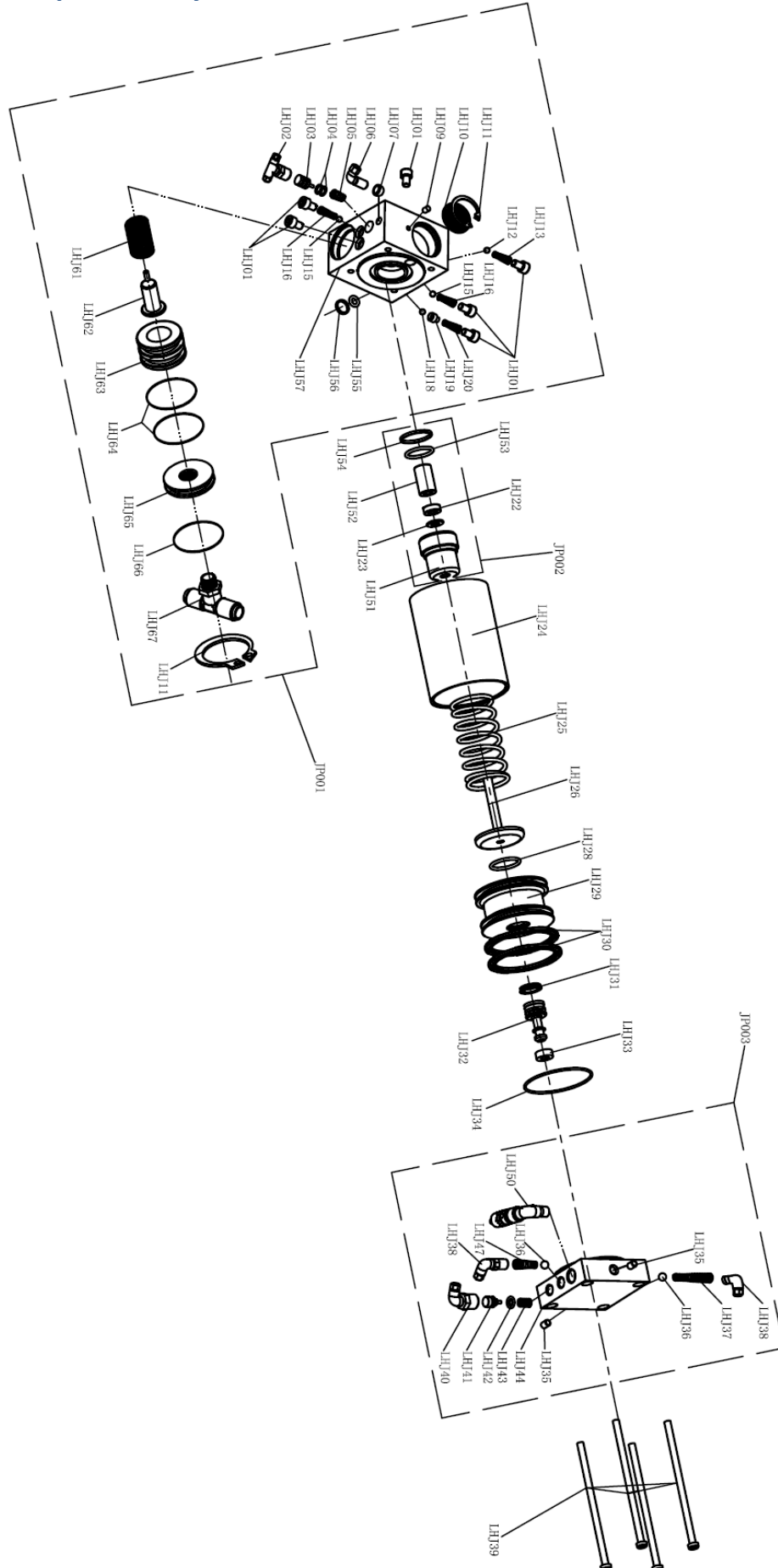
Item	Description	Part No.	Qty
J001	Cylinder assy.	ZCF1036	1
J002	Pump assembly	ZCF1029	1
J005	Tie in	ZCF1143	4
J006	Lifting Handle (set)	ZCF1047	1
J007	Housing	ZCF1091	1
J008A	45 mm extension	ZCF1056	1
J008B	75mm extension	ZCF1057	1
J010	Switch assembly	ZCF1001	1
J011	Handle grip	ZCF1108	2
J012	Handle assembly	ZCF1105	1
J013	Tie in	ZCF1144	2
J014	Handle shaft	ZCF1073	1
J015	Single wheel set	ZCF1016	2
J016	Screw	ZCF1093	4
J017	Screw	ZCF1094	1
J018	Screw	ZCF1095	3
J019	Screw	ZCF1096	4
J020	Protection cover	ZCF1101	1
J021	Oil hose	ZCF1098	1

9.2 Cylinder Assembly Parts Breakdown and List



Assy No.	Item	Description	Part No.	Qty
	J317	Saddle	ZCF1127	1
J3D	J318 J319* J320*	Piston assembly	ZCF1125	1
J3C	J311* J312* J313 J314* J315*	Inner sleeve assembly	ZCF1124	1
	J316	Locking ring	ZCF1126	1
J3B	J306* J307* J308 J309* J310*	Inner sleeve assembly	ZCF1123	1
J3A	J301* J302* J303 J323 J304* J305* J321 J324	Base + outer sleeve assembly	ZCF1122	1
*(Included in)		Cylinder Seal Kit	ZCF1024	1

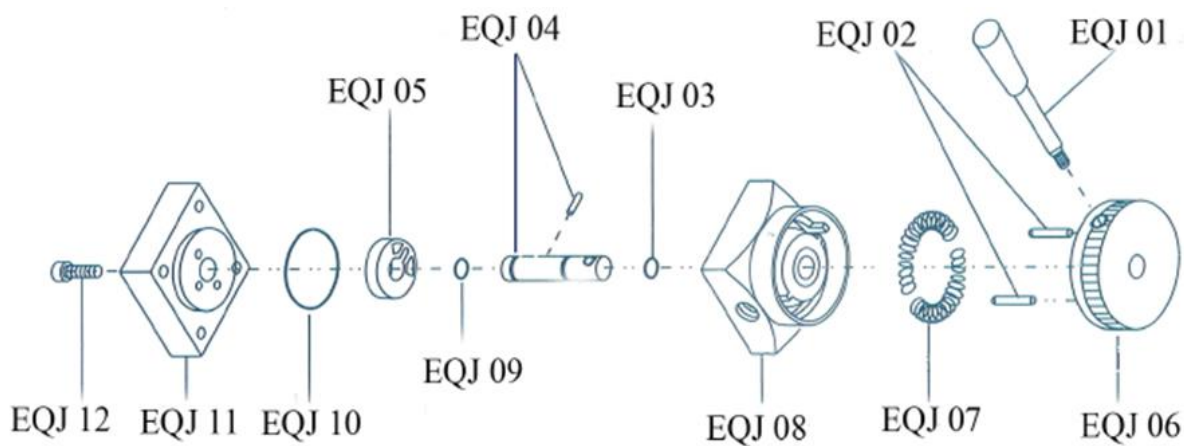
9.3 Pump Assembly Parts Breakdown and List



9.3.1 Pump Assembly Parts List

Item	Description	Part No.	Qty	Item	Description	Part No.	Qty
LHJ01	Screw	ZCF1092	6	LHJ35	Screw	ZCF1177	2
LHJ02	Tie in	ZCF1145	1	LHJ36	Rubber ball	ZCF1178	2
LHJ03	Oil drain bolt	ZCF1152	1	LHJ37	Spring	ZCF1179	1
LHJ04	O-ring*	ZCF1153	2	LHJ38	Tie in	ZCF1147	2
LHJ05	Spring	ZCF1154	1	LHJ39	Screw	ZCF1180	4
LHJ06	Tie in	ZCF1146	1	LHJ40	Tie in	ZCF1148	1
LHJ07	Filter	ZCF1155	1	LHJ41	Piston	ZCF1181	1
LHJ09	Screw	ZCF1156	1	LHJ42	O-ring*	ZCF1182	1
LHJ10	Silencer	ZCF1157	1	LHJ43	Spring	ZCF1183	1
LHJ11	Clamp	ZCF1158	2	LHJ44	Air inlet valve	ZCF1184	1
LHJ12	Steel ball	ZCF1159	1	LHJ47	Spring	ZCF1185	1
LHJ13	Spring	ZCF1160	1	LHJ50	Safety valve	ZCF1186	1
LHJ15	Steel ball	ZCF1161	2	LHJ51	Oil pump	ZCF1187	1
LHJ16	Spring	ZCF1162	2	LHJ52	Guider sleeve	ZCF1188	1
LHJ18	Steel ball	ZCF1163	1	LHJ53	O-ring*	ZCF1189	1
LHJ19	Screw nut	ZCF1164	1	LHJ54	Locking ring*	ZCF1190	1
LHJ20	Spring	ZCF1165	1	LHJ55	O-ring*	ZCF1191	1
LHJ22	B3 seal*	ZCF1166	1	LHJ56	Locking ring*	ZCF1192	1
LHJ23	Locking ring*	ZCF1167	1	LHJ57	Check valve	ZCF1193	1
LHJ24	Air cylinder	ZCF1168	1	LHJ61	Spring	ZCF1194	1
LHJ25	Spring	ZCF1069	1	LHJ62	Oil drain bolt	ZCF1195	1
LHJ26	Piston rod	ZCF1169	1	LHJ63	Oil drain piston	ZCF1196	1
LHJ28	O-ring*	ZCF1170	1	LHJ64	O-ring*	ZCF1197	2
LHJ29	Piston	ZCF1171	1	LHJ65	Oil drain cover	ZCF1198	1
LHJ30	Seal*	ZCF1172	2	LHJ66	O-ring*	ZCF1199	1
LHJ31	Seal*	ZCF1173	1	LHJ67	Tie in	ZCF1149	1
LHJ32	Piston	ZCF1174	1	JP001	Check valve assembly	ZCF1200	1
LHJ33	Rubber cap*	ZCF1175	1	JP002	Oil pump assembly	ZCF1201	1
LHJ34	O-ring*	ZCF1176	1	JP003	Air inlet valve assy.	ZCF1202	1
				*	Pump seal kit	ZCF1004	1

9.4 Switch Assembly Parts Breakdown and List



Item	Description	Part No.	Qty
EQJ01	Handle	ZCF1000	1
EQJ02	Straight pin	ZCF1203	2
EQJ03	O-ring	ZCF1204	1
EQJ04	Central spindle	ZCF1205	1
EQJ05	Valve base	ZCF1206	1
EQJ06	Switch cap	ZCF1207	1
EQJ07	Spring	ZCF1208	2
EQJ08	Valve body	ZCF1209	1
EQJ09	O-ring	ZCF1210	1
EQJ10	O-ring	ZCF1211	1
EQJ11	Valve base	ZCF1212	1
EQL12	Screw	ZCF1213	4