

DURAPAC
ENGINEERED FOR RELIABILITY

Instruction Manual

045 Series Auto, 2 Speed Compact Electric
Power Unit – SPEM45054L



Maximum Operating Pressure – 700 bar



This is a safety alert symbol. It is used to alert you to potential personal injury hazards. Obey all safety messages that follow this symbol to avoid injury or death

1.0 Product Information

DURAPAC – 045 Series Auto 2 Speed Power Units are engineered to meet Industrial Standards for Performance and Safety. The SPEM45054L model delivers 2.5 Lpm up to 70 bar and 0.35 Lpm up to 700 bar pressure on double acting cylinders and tools. The power unit has a 4-way manual valve to actuate Advance/Hold/Retract functions and a remote pendant for motor ON/OFF function. The power unit has 230 Volt or 115 Volt options and is driven by a 0.45 kW, 50/60 Hz single phase electric motor and is ideal for lifting and maintenance applications. The power unit is lightweight and easily portable using the carry handle.

Special skill, knowledge and training may be required for a specific task and the product may not be suitable for all jobs. The user must ultimately make the decision regarding suitability of the product for any given task and assume the responsibility of safety for all in the work area. Contact a Durapac representative if you are unsure of your power unit's suitability for a particular application.

2.0 Receiving Instructions

It is recommended prior to use that an inspection be done by qualified personnel and that any missing or damaged parts, decals, warning/safety labels or signs are replaced with Durapac authorised replacement parts only. Any power unit that appears to be damaged in any way, is worn, leaking or operates abnormally should be removed from service immediately until such time as repairs can be made. Any power unit that has been or suspected to have been subject to a shock load should be removed from service immediately until inspected by a Durapac authorised service centre. Owners and operators of this equipment should be aware that the use and subsequent repair of this equipment may require specialised training and knowledge.

3.0 Safety

Save these instructions. For your safety, read and understand the information contained within. The owner and operator should understand this product and safe operating procedures before attempting to use this product. Instructions and safety information should be conveyed in the operator's native language before use of this product is authorised. Make certain that the operator thoroughly understands the inherent dangers associated with the use and misuse of the product. If any doubt exists as to the safe and proper use of this product as outlined in this factory authorised manual, remove from service immediately.



DANGER:

- To avoid personal injury, keep hands and feet away from work area during operation
- **Do NOT** handle pressurised hoses. Escaping oil under pressure can penetrate the skin causing serious injury. If oil is injected under the skin, see a doctor immediately
- Stay clear of loads supported by hydraulics. A cylinder, when used as a load lifting device, should never be used as a load holding device. After the load has been raised or lowered, it must always be supported mechanically

**WARNING:**

- The system operating pressure must not exceed the pressure rating of the lowest rated component in the system. Install pressure gauges in the system to monitor operating pressure. It is your window to what is happening in the system
- Always wear appropriate personal protective equipment (PPE) when operating hydraulic equipment. The operator must take precaution against injury due to failure of the tool or work piece(s)
- **Do NOT** hold or stand directly in line with any hydraulic connections while pressurising
- **Do NOT** attempt to disconnect hydraulic connections under pressure. Release all line pressure before disconnecting hoses
- All personnel must be clear before lowering load or depressurising the system
- **Do NOT** attempt to lift a load weighing more than the capacity of the cylinder

**IMPORTANT:**

- If at any stage, the safety related decals become hard to read, these must be replaced
- Minimum age of the operator must be 18 years. The operator must have read and understood all instructions, safety issues, cautions and warnings before starting to operate the equipment. The operator is responsible for this activity towards other persons
- **Do NOT** lift hydraulic equipment by the hoses or couplers. Use the carrying handle or other means of safe transport
- Hydraulic equipment must only be serviced by a qualified hydraulic technician. For repair service, contact the Durapac authorised service centre in your area. To protect your warranty, use only high-quality hydraulic oil

**CAUTION:**

- **KEEP HYDRAULIC EQUIPMENT AWAY FROM FLAMES AND HEAT.** Hydraulic fluid can ignite and burn. Excessive heat will soften packings and seals, resulting in fluid leaks. Heat also weakens hose materials and packings. For optimum performance do not expose equipment to temperatures of 55°C (131°F) or higher. Protect all equipment from weld spatter
- No alteration should be made to this device

3.1 Hydraulic Power Units

- **Do** use a gauge or other load measuring instrument to verify load
- **Do NOT** exceed the rated capacity of the power unit or any equipment in the system. Burst hazard exists if connection pressure exceeds rated pressure
- **Do NOT** operate the system with bent or damaged couplers or damaged threads
- **Do NOT** subject the power unit and its components to shock loads
- Use only Durapac approved accessories and components



- **Do NOT** connect to an application which can return more oil to the reservoir than the power unit reservoir can hold
- **Do NOT** connect power unit to a hydraulic system that is powered by another pump

3.2 Hydraulic Hoses & Fluid Transmission Lines

- Avoid short runs of straight-line tubing. Straight line runs do not provide for expansion and contraction due to pressure and/or temperature changes
- Reduce stress in tube lines. Long tubing runs should be supported by brackets or clips. Before operating the power unit, connections should be tightened securely and leak-free. Over tightening can cause premature thread failure or high-pressure fittings to burst
- Should a hydraulic hose ever rupture, burst or need to be disconnected, immediately shut off the power unit and release all pressure. Never attempt to grasp a leaking pressurised hose with your hands. The force of escaping hydraulic fluid can inflict injury
- **Do NOT** subject the hose to potential hazard such as fire, sharp objects, extreme heat or cold or heavy impact
- **Do NOT** allow the hose to kink, twist, curl, crush, cut or bend so tightly that the fluid flow within the hose is blocked or reduced. Periodically inspect the hose for wear
- Hose material and coupler seals must be compatible with the hydraulic fluid used. Hoses also must not come in contact with corrosive materials such as battery acid, creosote-impregnated objects and wet paint. Never paint a coupler or hose

FAILURE TO HEED THESE WARNINGS MAY RESULT IN PERSONAL INJURY AS WELL AS PROPERTY DAMAGE.

4.0 Installation

-  **IMPORTANT:** Always secure threaded port connections with high grade, non-hardening pipe thread sealant. Teflon tape can be used if only one layer of tape is used and it is applied carefully, two threads back, to prevent the tape from being introduced into hydraulic system, which could cause jamming of precision-fit parts
-  To avoid power loss between the electrical outlet and the power unit motor, use the shortest possible extension cord

4.1 Familiarise yourself with the specifications and illustrations in this owner’s manual. Know your power unit, its limitations and how it operates before attempting to use. Refer to the specification chart below or if in doubt, contact a Durapac representative.

Model Number	kW	Voltage (1 Ph.)	Hz	Amps	Usable Oil Capacity (L)	Max. Pressure Rating (bar)	Flow Rate (Lpm)		Remote Pendant Function 2.4 mtr	Weight (kg)
							70 bar	700 bar		
SPEM45054	0.45	230	50/60	4.5	2.0	700	2.5	0.35	MOTOR ON/OFF	18.1
SPEM45054L	0.45	230	50/60	4.5	4.0	700	2.5	0.35	MOTOR ON/OFF	19.6
SPEM45054-115V	0.45	115	50/60	11.0	2.0	700	2.5	0.35	MOTOR ON/OFF	18.1
SPEM45054L-115V	0.45	115	50/60	11.0	4.0	700	2.5	0.35	MOTOR ON/OFF	19.6

4.2 Make hydraulic connections – Clean all areas around the oil port of power unit and cylinder. Clean all hose ends, couplers and union ends. Remove the manifold plug and connect the 3/8” NPTF oil output port with a 700 bar hydraulic hose.

4.3 Check all system fittings and connections to be sure they are tight and leak free.

4.4 Check oil level in reservoir before operating power unit.

4.5 Power connection – Confirm the power unit’s voltage is the same as the voltage being supplied by the site, the source is a stable supply and that the motor is correctly grounded.

-  Ensure power is switched off prior to connection of hoses and equipment to prevent early pressurisation

4.6 Remove air from the system – Air can accumulate in the hydraulic system during the initial setup or after prolonged use, causing the cylinder to respond slowly or in an unstable manner. Should removal of air from power unit be required, please follow the steps in 6.2 – Bleeding Air from the System in the Maintenance Section.

5.0 Operation



IMPORTANT:

- Always monitor pressure, load or position using suitable equipment. Pressure may be monitored by means of an optional manifold and gauge. Correct application position can only be determined by the operator of the equipment
- **Never** set the relief valve to a higher pressure than the maximum rated pressure of the power unit. Higher settings may result in equipment damage and/or personal injury
- **Do NOT** remove the relief valve
- **Do NOT** operate a power unit that is disconnected from the application. If operated in this condition, the hose and connections will become pressurised. This increases the chance of a burst hazard. Damage may also occur to the power unit and its components
- This power unit is designed for indoor use, please protect from the elements if used outside

5.1 Before Using the Power Unit

- 5.1.1 Check all system fittings and connections to be sure they are tight and leak free.
- 5.1.2 Check oil level in reservoir.
- 5.1.3 Open the oil/air vent by turning it 1/2 turns.

 **CAUTION:** The vent plug must be open whenever the power unit is running

5.2 Power Unit Operation

- 5.2.1 Plug in power unit.
- 5.2.2 Shift manual valve handle to left side position (stop at 45°).
- 5.2.3 Press ON switch to run the motor and to **Advance** the cylinder (flow to port “A”, port “B” returns flow to the reservoir).
- 5.2.4 Release ON switch to **Hold** and stop the motor.
- 5.2.5 Before retracting the cylinder, return the valve handle to neutral (front) position (both ports “A” and “B” are blocked). Shift valve handle to right side position (stop at 45°) and press ON switch to **Retract** the cylinder (flow to port “B”, port “A” returns flow to the reservoir).

5.3 Relief Valve Adjustment

All power units contain a factory set internal relief valve to prevent over-pressurisation of the system. A deck mounted adjustable pressure relief valve is also included and can be set to lower working pressures (see Item 4, shown in Section 8.1 – High Level Description of Parts).

Turn the adjusting screw a few turns (counterclockwise) to decrease the pressure setting to the desired level. Clockwise rotation of the adjusting screw will increase pressure.

6.0 Maintenance



IMPORTANT:

- Disconnect power supply before disassembly or repair
- Check oil level regularly
- Use only good quality hydraulic fluid. **Do NOT** use brake fluid, transmission fluid, turbine oil, motor oil, alcohol, glycerine etc. Use of anything other than good quality hydraulic oil will void warranty and damage the power unit, hose, and application. We recommend Durapac Hydraulic Oil or equivalent
- Equipment must only be serviced by a qualified hydraulic technician. For repair service, contact your local Durapac authorised service centre
- Damage to hydraulic hoses may not be detected during visual inspections. For this reason, Durapac recommends that hydraulic hoses be replaced on a regular basis
- Tighten connections as needed. Use non-hardening pipe thread compound when servicing connections

Dirt, sand, etc. will quickly ruin any hydraulic system. Ensure that couplings are clean and free of foreign matter. After each use, clean couplings and attach dust caps.

Maintenance is required when wear or leakage is noticed. Periodically inspect all components to detect any problem that may require service and maintenance.

6.1 Adding Hydraulic Fluid

 **WARNING:** Always add oil with cylinders fully retracted (or extended, if pull cylinders) or the system will contain more oil than the reservoir can hold

- 6.1.1 Depressurise and disconnect hydraulic hose from application/cylinder.
- 6.1.2 With the power unit in its upright, horizontal position, remove the air vent plug located on the top plate of the reservoir.
- 6.1.3 Take out the filling plug.
- 6.1.4 Use a small funnel to fill the oil to within 20mm of the opening.
- 6.1.5 Bleed air from system if necessary.
- 6.1.6 Wipe up any spilled fluid and reinstall the air vent plug/reservoir cap.

6.2 Bleeding Air from the System

- 6.2.1 Repeat Steps 6.1.1 to 6.1.4 (above), if required.
- 6.2.2 Invert cylinder and place at a lower level than the power unit reservoir.
- 6.2.3 Extend and retract the cylinder several times without putting a load on the system. Air will be released into the power unit reservoir.
- 6.2.4 Recheck oil level after removing air.

6.3 Changing Hydraulic Fluid

⚠ For best results, change fluid once a year or every 300 hours of use

- 6.3.1 Repeat Steps 6.1.1 to 6.1.3 (above).
- 6.3.2 Pour used fluid into a sealable container.
- 6.3.3 Repeat Steps 6.1.4 to 6.1.6 (above).
- 6.3.4 Dispose of fluid in accordance with local regulations.

6.4 Replacing Carbon Brushes

⚠ Carbon brushes need to be replaced by a qualified technician

⚠ Replace when carbon brush has been worn down to 6mm in length (as shown below) or every 150 hours of use. When worn, the motor will stop automatically

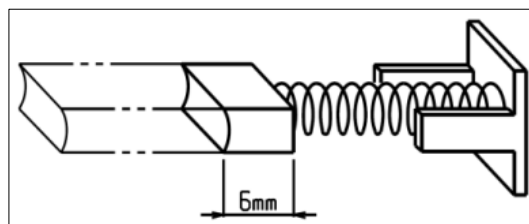

Fig. 1 – Carbon Brush Replacement

- 6.4.1 Remove rubber caps (x 2).
- 6.4.2 Use a screwdriver to loosen and remove inside fitting screws so that carbon brushes can be taken out.
- 6.4.3 Replace with new carbon brushes, fix the screws and rubber caps.

6.5 Storage

- 6.5.1 When not in use, depressurise and disconnect the power unit from the application.
- 6.5.2 Wipe clean thoroughly and store in a clean, dry environment. Avoid temperature extremes.
- 6.5.3 For transportation or long storage, replace the air vent plug with shipping plug.
- 6.5.4 Shield power unit with a protective cover.

7.0 Troubleshooting

⚠ WARNING: Disconnect power supply before disassembly or repair

Problem	Cause	Solution
Motor will not start	Inadequate or faulty electrical supply	<ul style="list-style-type: none"> • Check the line voltage • Check the condition of the power unit’s power cord • Check the condition of extension cords • Check for tripped circuit breaker. Be sure breaker is of adequate size • Contact a qualified electrician for any necessary repairs
	Carbon brush is worn	<ul style="list-style-type: none"> • Refer to 6.4 – Replacing Carbon Brushes
Noisy operation	Air trapped in system	<ul style="list-style-type: none"> • Check all points where air may leak into the system • Refer to 6.2 – Bleeding Air from the System
	Power unit reservoir too full	<ul style="list-style-type: none"> • Drain fluid to correct level
	Low fluid level in power unit reservoir	<ul style="list-style-type: none"> • Refer to 6.1 – Adding Hydraulic Fluid • Fill and bleed the system
Power unit oil is over-heating	Oil viscosity is too high	<ul style="list-style-type: none"> • Refer to 6.3 – Changing Hydraulic Fluid • Refill with a good quality hydraulic oil
	High pressure leakage on upper pressure plate	<ul style="list-style-type: none"> • Tighten plug
	Low fluid level in power unit reservoir	<ul style="list-style-type: none"> • Refer to 6.1 – Adding Hydraulic Fluid • Fill and bleed the system
Power unit runs but will not pump oil	Power unit is not primed	<ul style="list-style-type: none"> • Run power unit a few minutes tipping from side to side
	Externally adjustable relief valve is not correctly set	<ul style="list-style-type: none"> • Reset the relief valve to appropriate level
	Damaged o-ring	<ul style="list-style-type: none"> • Send to a Durapac authorised service centre for repair
	Defective control valve	<ul style="list-style-type: none"> • Send to a Durapac authorised service centre for repair
Power unit does not reach rated capacity	Low fluid level in reservoir	<ul style="list-style-type: none"> • Secure load by other means • Depressurise power unit and hose, remove application, then fill and bleed the system
	Leaking system components	<ul style="list-style-type: none"> • Repair or replace as necessary
Poor performance	Fluid level in power unit is low	<ul style="list-style-type: none"> • Secure load by other means • Depressurise power unit and hose, remove application, then fill and bleed the system

Problem	Cause	Solution
Application does not extend, move or respond to pressurised fluid	Overload condition	<ul style="list-style-type: none"> Remedy overload condition
	Loose couplers	<ul style="list-style-type: none"> Tighten couplers
	Faulty couplers	<ul style="list-style-type: none"> Replace couplers
	Malfunctioning power unit	<ul style="list-style-type: none"> Contact a Durapac authorised service centre for repair
Application does not fully extend (cylinder or tools)	Reservoir overfilled	<ul style="list-style-type: none"> Secure load by other means Depressurise power unit and hose, remove application, then drain fluid to proper level
	Low fluid level in power unit reservoir	<ul style="list-style-type: none"> Secure load by other means Depressurise power unit and hose, remove application, then fill and bleed the system
	Load above capacity of system	<ul style="list-style-type: none"> Use correct equipment
Application responds slower than normal	Loose connection or coupler	<ul style="list-style-type: none"> Tighten couplers
	Restricted hydraulic line or fitting	<ul style="list-style-type: none"> Clean and replace if damaged
	Power unit not operating correctly	<ul style="list-style-type: none"> Check power unit's operating instructions Repair or replace as necessary
	Low fluid level in power unit reservoir	<ul style="list-style-type: none"> Secure load by other means Depressurise power unit and hose, remove application, then fill and bleed the system
Application responds to pressurised fluid, but system does not maintain pressure	Leaky connection	<ul style="list-style-type: none"> Clean, reseal with thread sealant, and tighten connection
	Leaking cylinder seals	<ul style="list-style-type: none"> Replace worn seals. Look for excessive contamination or wear. Replace contaminated fluid
	Power unit or valve not operating correctly	<ul style="list-style-type: none"> Contact a Durapac authorised service centre for repair
	Overload condition	<ul style="list-style-type: none"> Remedy overload condition
Application does not return fluid to power unit (i.e. cylinder will not retract)	Closed release valve	<ul style="list-style-type: none"> Secure load by other means Open release valve
	Loose couplers	<ul style="list-style-type: none"> Secure load by other means Tighten couplers
	Blocked hydraulic lines	<ul style="list-style-type: none"> Secure load by other means Clean and flush lines
	Weak or broken retraction springs	<ul style="list-style-type: none"> Secure load by other means Contact a Durapac authorised service centre for repair
	Internally damaged cylinder	<ul style="list-style-type: none"> Secure load by other means Contact a Durapac authorised service centre for repair
	Power unit reservoir too full	<ul style="list-style-type: none"> Secure load by other means Depressurise power unit and hose, remove application, then drain fluid to proper level

8.0 Parts Breakdown & List

8.1 High Level Description of Parts

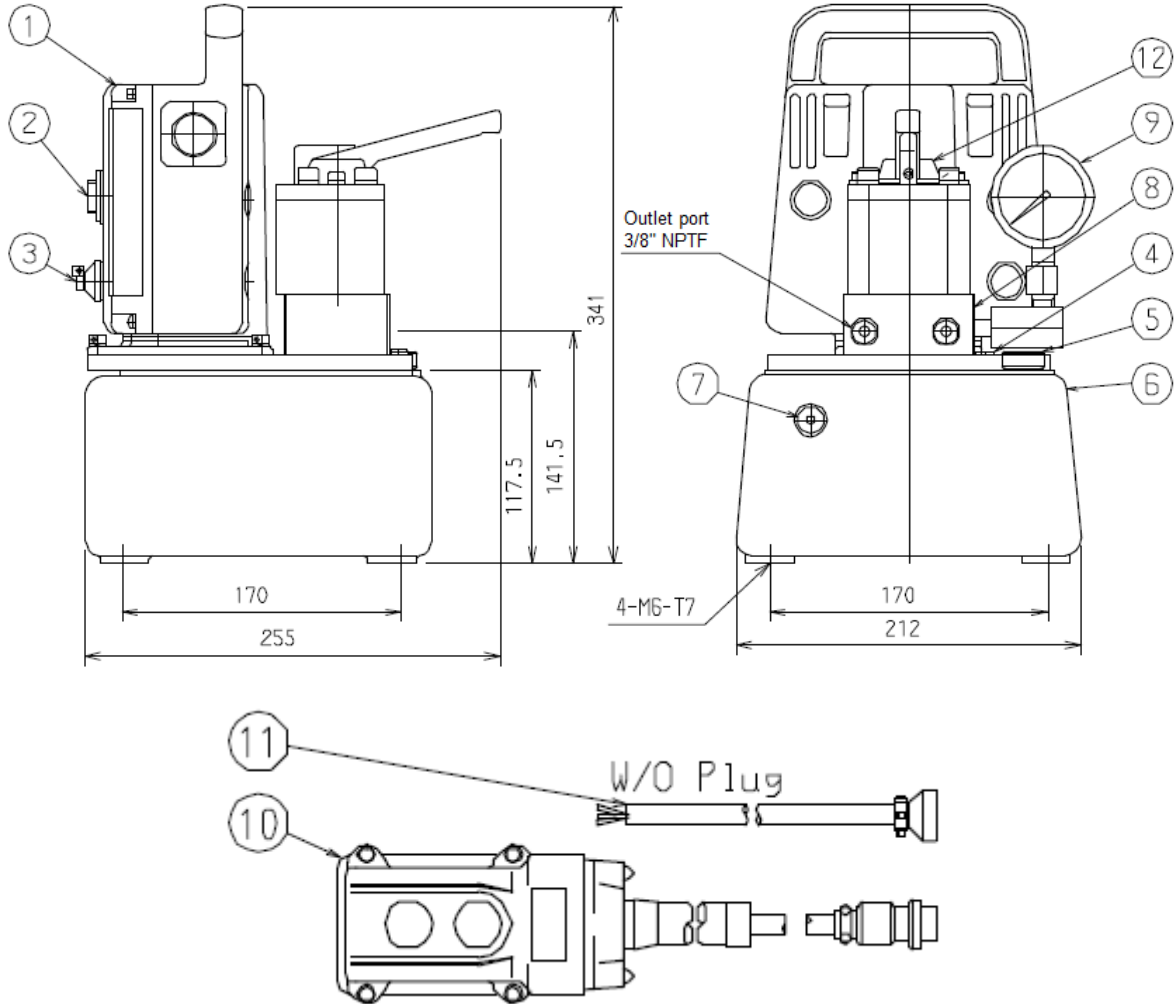

Item	Description
1	Electric motor
2	Metal plug socket
3	Power supply plug
4	HP relief valve
5	Oil plug
6	Reservoir
7	Oil gauge
8	Delivery port block
9	Pressure gauge
10	Pendant switch 2.4m
11	Power cable
12	Manual valve

9.0 Electric Schematics

9.1 – 230 Volt

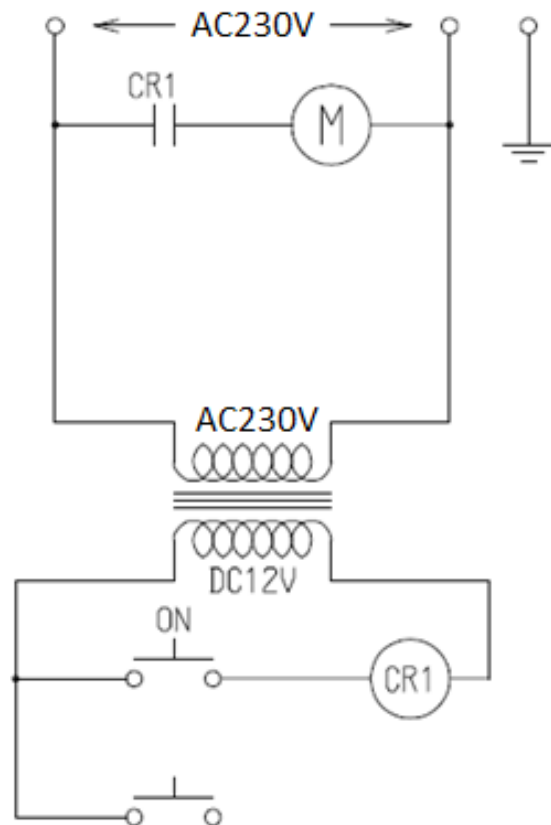

9.2 – 115 Volt

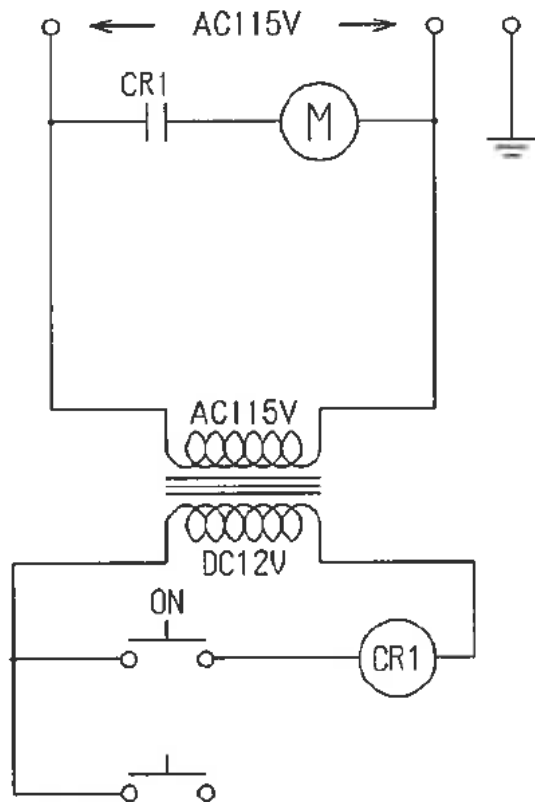

10.0 Hydraulic Schematic

