



Instruction Manual

Self-contained Hydraulic Cutter
Model – HC-45S



Maximum Operating Pressure – 700 bar



This is a safety alert symbol. It is used to alert you to potential personal injury hazards. Obey all safety messages that follow this symbol to avoid injury or death

1.0 Product Information

DURAPAC – Hydraulic cutters are engineered to meet Industrial Standards for Performance and Safety. The HC-45S is a self-contained cutter with a spring return and a 180° rotating head. They are compact, lightweight, easy to use and supplied in a heavy-duty canvas carry bag. They feature superior guillotine-type cutting, flip-top latch for easy insertion of cutting material and blades that are easily replaceable.

The HC-45S cuts with ease though round bar, wire rope, wire strand and more. It is a proven performer in the electrical, railway, mining, manufacturing and construction industries.

Note – the cutting of piano wire is prohibited.

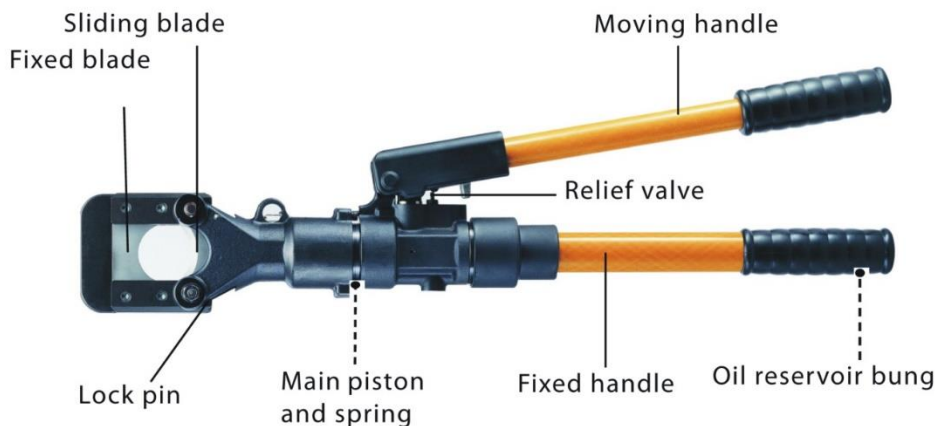

Figure 1 – HC-45S Subassembly

Special skill, knowledge and training may be required for a specific task and the product may not be suitable for all jobs. The user must ultimately make the decision regarding suitability of the product for any given task and assume the responsibility of safety for all in the work area. Contact a Durapac representative if you are unsure of your hydraulic cutter’s suitability for a particular application.

2.0 Receiving Instructions

It is recommended prior to use that an inspection be done by qualified personnel and that any missing or damaged parts, decals, warning/safety labels or signs are replaced with Durapac authorised replacement parts only. Any hydraulic cutter that appears to be damaged in any way, is worn, leaking or operates abnormally should be removed from service immediately until such time as repairs can be made. Any hydraulic cutter that has been or suspected to have been subject to a shock load should be removed from service immediately until inspected by a Durapac authorised service centre. Owners and operators of this equipment should be aware that the use and subsequent repair of this equipment may require specialised training and knowledge.

3.0 Safety

Save these instructions. For your safety, read and understand the information contained within. The owner and operator should have an understanding of this product and safe operating procedures before attempting to use this product. Instructions and safety information should be conveyed in the

operator's native language before use of this product is authorised. Make certain that the operator thoroughly understands the inherent dangers associated with the use and misuse of the product. If any doubt exists as to the safe and proper use of this product as outlined in this factory authorised manual, remove from service immediately.

**DANGER:**

- To avoid personal injury keep hands and feet away from work area during operation

**WARNING:**

- Always wear appropriate personal protective equipment (PPE) when operating hydraulic equipment. The operator must take precaution against injury due to failure of the tool or work piece(s)

**IMPORTANT:**

- If at any stage, the safety related decals become hard to read, these must be replaced
- Minimum age of the operator must be 18 years. The operator must have read and understood all instructions, safety issues, cautions and warnings before starting to operate the equipment. The operator is responsible for this activity towards other persons
- Hydraulic equipment must only be serviced by a qualified hydraulic technician. For repair service, contact the Durapac authorised service centre in your area. To protect your warranty, use only high quality hydraulic oil

**CAUTION:**

- **KEEP HYDRAULIC EQUIPMENT AWAY FROM FLAMES AND HEAT.** Hydraulic fluid can ignite and burn. Excessive heat will soften packings and seals, resulting in fluid leaks. Heat also weakens hose materials and packings. For optimum performance do not expose equipment to temperatures of 65°C (150°F) or higher. Protect all equipment from weld spatter
- No alteration should be made to this device

3.1 Hydraulic Cutters

- Keep hands off the cutting head section while operating the product
- This product is **NOT** an insulator. Proper equipment should be used to avoid electrical shock
- **Do NOT** keep this product in places with high temperatures, high humidity or direct sunlight
- Suggested working temperatures -10°C to 40°C
- Hydraulic fluid temperatures over 65°C might cause damage to components sealed inside the product

FAILURE TO HEED THESE WARNINGS MAY RESULT IN PERSONAL INJURY AS WELL AS PROPERTY DAMAGE.

4.0 Installation

- 4.1 Familiarise yourself with the specifications and illustrations in this owner’s manual. Know your hydraulic cutter, its limitations and how it operates before attempting to use. Refer to the specification table below or if in doubt, contact a Durapac representative.

Wire Rope			Soft	Soft	Soft	ACSR (mm)	Cu Strands (mm)	Al Strands (mm)	Max. Pressure (bar)	Oil Required (cc)	Max. Output (kN)	Cylinder Stroke (mm)	Length (mm)	Weight (kg)
6x7 (mm)	6x12 (mm)	6x19 (mm)	Steel Bar (mm)	Copper Bar (mm)	Aluminium Bar (mm)									
40	40	40	20	32	40	40	40	40	700	70	95.5	50.0	683	6.7

Cutting of piano wire is not recommended

- 4.2 Check oil level in reservoir before operating cutter.
- 4.3 Remove air from the system – Air can accumulate in the hydraulic system during the initial setup or after prolonged use, causing the cylinder to respond slowly or in an unstable manner. Should removal of air from the hydraulic cutter be required, please follow the steps in 6.3 – Bleeding Air from the System in the Maintenance Section.

5.0 Operation



IMPORTANT:

- The maximum cutting capacity of this tool **includes** the thickness of the cable covering. Keep this in mind when selecting the appropriate cable to use. If in doubt, use another tool to cut away the cable covering before commencing cutting with this tool
- Only attempt to cut cables which fit the tool specifications. No other materials are to be cut

5.1 Before Operation

- 5.1.1 Make sure all parts of the product are clean, without rust or loose parts.
- 5.1.2 Check that no leakage occurs while the tool is resting or while the product is being tested without cables.

5.2 Operation

- Stop operating immediately in the case of any abnormalities

- 5.2.1 Release the hydraulic fluid pressure and retract the piston before opening the tool head. To release the pressure; pull out the moving handle and rotate it clockwise. Push down the moving handle. Once the piston returns to its starting position the product is ready to operate.

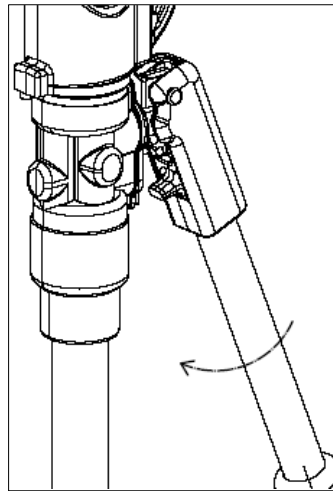

Figure 2 – Release Pressure

- 5.2.2 Remove the tool head lock pin and pull back the upper blade to open the cutting head.
- 5.2.3 Place the cable between the blades at the desired cutting point. Close the cutter head and secure the latch pin.

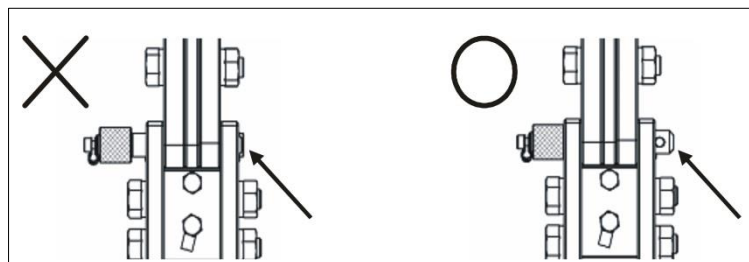

Figure 3 – Latch Pin Position

- 5.2.4 Position the cable at the **centre** of the fixed blade. Improper positioning of the cable on the edge might cause damage to the blade or deform the tool.

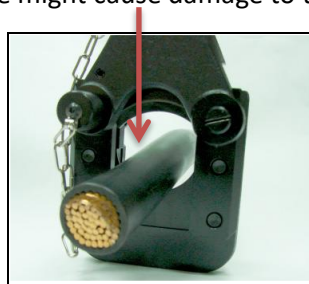

Figure 4 – Centre cable

- 5.2.5 Pump the moving handle back and forth to advance the piston and sliding blade forward.
- 5.2.6 Keep pumping the moving handle until the cable is cut.
- 5.2.7 Turn the moving handle clockwise and press down the release lever by pushing down the moving handle. The tool will return to its starting position.
- 5.2.8 Repeat steps 5.2.3 – 5.2.7 until the cutting operation is complete.

5.3 After Operation

- 5.3.1 Clean the product and blades.

6.0 Maintenance



IMPORTANT:

- Check oil level regularly and make sure the reservoir is full
- Use only good quality hydraulic fluid. **Do NOT** use brake fluid, transmission fluid, turbine oil, motor oil, alcohol, glycerine etc. Use of anything other than good quality hydraulic oil will void warranty and damage the cutter. We recommend Durapac Hydraulic Oil or equivalent
- Equipment must only be serviced by a qualified hydraulic technician. For repair service, contact your local Durapac authorised service centre
- Tools with worn or damaged blades may cause property damage or even personal injury
- The hydraulic relief valve pressure should only be adjusted by a Durapac representative

Maintenance is required when wear or leakage is noticed. Periodically inspect all components to detect any problem that may require service and maintenance.

Keep the tool head free of dirt and metal chips. Use a lubricant to clean the tool when necessary.

Routine application of rust preventative oil to the product is needed. Avoid bringing the tool into contact with water or solvents.

6.1 Blade Replacement

6.1.1 Fixed Blade Replacement

- 6.1.1.1 Open the tool head and pull back the fixed blade. Remove the four small screws to unfasten the blade.
- 6.1.1.2 Position the new blade, reassemble the small screws.
- 6.1.1.3 Ensure that all components are tight and that the blade opens and closes smoothly.

6.1.2 Moving Blade Replacement

- 6.1.2.1 Advance the lower blade until the connecting pin is visible on the main piston.
- 6.1.2.2 With the tool head open, remove the connecting pin to unfasten the blade.
- 6.1.2.3 Insert the new blade and reassemble the connecting pin to secure the blade in place.
- 6.1.2.4 Ensure that all components are tight and the blade moves back and forth smoothly.

6.2 Adding Hydraulic Fluid

- 6.2.1 Position the tool upside-down in a vice with the pump handle in the open position.
- 6.2.2 Unscrew the main handle from the body and then remove the oil reservoir cap.
- 6.2.3 Use a small funnel to fill the reservoir to the top of the oil filler hole.
- 6.2.4 Bleed air from the system (below)
- 6.2.5 Close the rubber reservoir, insert the filler cap and reassemble the main handle.

6.3 Bleeding Air from the System

- 6.3.1 Repeat Steps 6.2.1 to 6.2.3 (above), if required.
- 6.3.2 Pump the moving handle a few times to advance the cylinder.
- 6.3.3 Press the release lever to release the pressure in the hydraulic circuit until the cylinder is fully retracted and the oil has returned completely into the reservoir.
- 6.3.4 Repeat the process several times to ensure that all air bubbles are removed.
- 6.3.5 Recheck oil level after removing air.

6.4 Changing Hydraulic Fluid

 For best results, change fluid once a year or every 300 hours of use

- 6.4.1 Repeat Steps 6.2.1 to 6.2.2 (above).
- 6.4.2 Pour used fluid into a sealable container.
- 6.4.3 Repeat Steps 6.2.3 to 6.2.5 (above).
- 6.4.4 Dispose of fluid in accordance with local regulations.

6.5 Storage

- 6.5.1 Check to ensure that all pieces are in good working condition.
- 6.5.2 Apply rust preventive oil to the product and blades before returning to the carrying case.

7.0 Troubleshooting

Problem	Cause	Solution
Cable cannot be cut	Worn or damaged blades	<ul style="list-style-type: none"> • Replace blades
	Cables are over specification	<ul style="list-style-type: none"> • Use tool that is appropriate for cutting requirements
	Internal leakage	<ul style="list-style-type: none"> • Send to a Durapac authorised service centre for repair
Handle is jammed or unable to rotate to release pressure	Foreign objects preventing movement	<ul style="list-style-type: none"> • Clean the moving handle to remove impediments
	Cylinder is loaded at end of stroke	<ul style="list-style-type: none"> • Pressure can be released by pressing down the release lever manually
	Torsional spring is damaged	<ul style="list-style-type: none"> • Send to a Durapac authorised service centre for repair
Sliding blade is jammed or unable to retract after operation	Worn or damaged blades	<ul style="list-style-type: none"> • Replace blades
	Blade guide pieces are blocked with impediments	<ul style="list-style-type: none"> • Use an airgun to remove impediments • Use lubricant to clean the tool
Lower blade does not advance or advances slowly	Air in the hydraulic system	<ul style="list-style-type: none"> • Refer to 6.3 – Bleeding Air from the System

8.0 Parts Breakdown and List

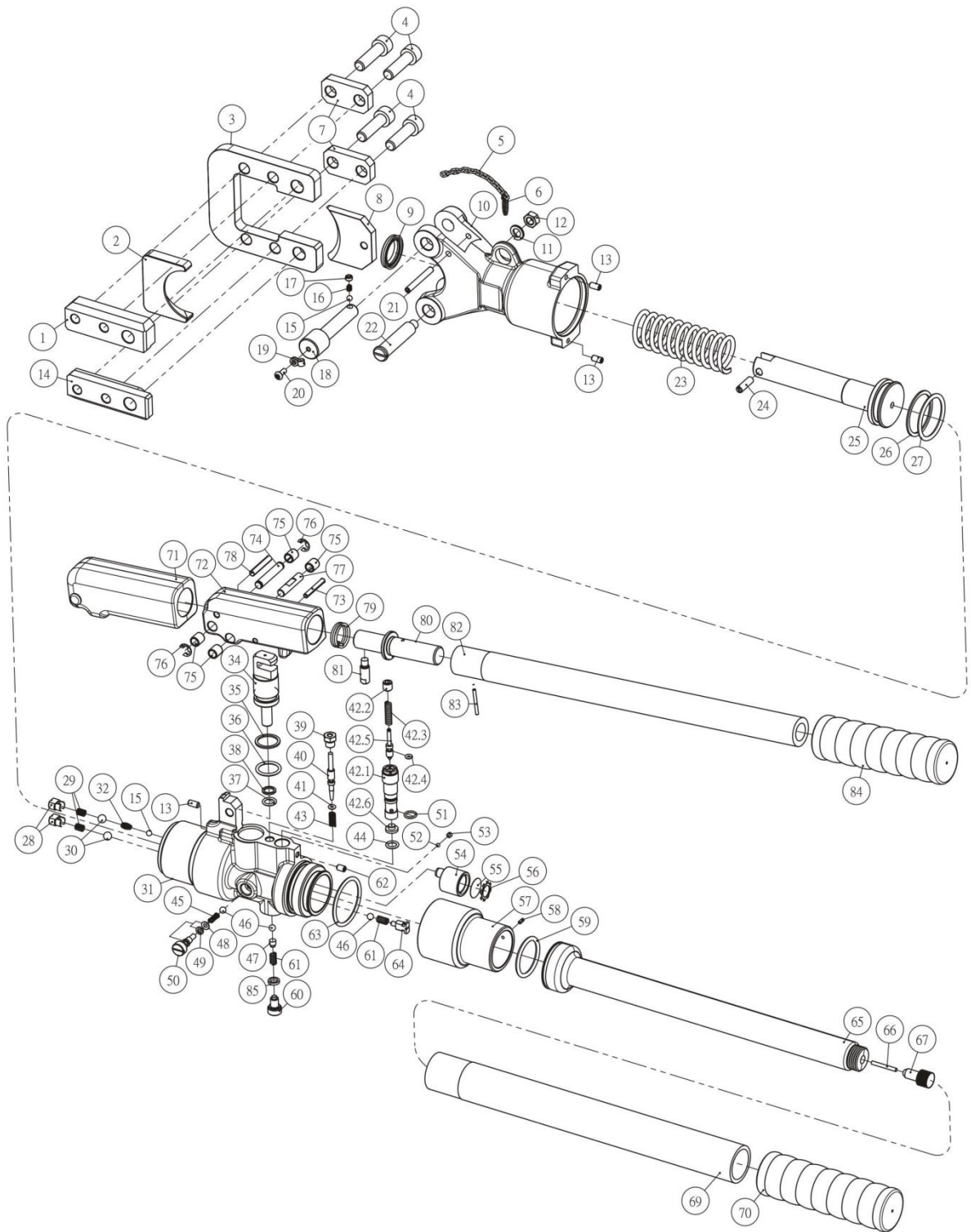

Item	Description	Qty	Item	Description	Qty
1	Blade guide	1	44	O-ring	1
2	Fixing blade	1	45	Compression spring	1
3	Blade guide	1	46	Ball	3
4	Screw	4	47	Ball seat	1
5	Chain	1	48	O-ring	2
6	Hook	1	49	Back-up ring	2
7	Locating plate	2	50	Valve screw	1
8	Moving blade	1	51	O-ring	1
9	Dust seal	1	52	Ball	1
10	Cylinder cover	1	53	Screw	1
11	Spring washer	1	54	Solid filter	1
12	Hex. nut	1	55	Oil screen	1
13	Screw	2	56	Push-in fastener	1
14	Blade guide	1	57	Extension tube	1
15	Ball	2	58	Spring pin	1
16	Compression spring	1	59	O-ring	1
17	Screw	1	60	Valve screw	1
18	Arresting lever	1	61	Compression spring	2
19	Buckle	1	62	Screw	1
20	Screw	1	63	O-ring	1
21	Spring pin	1	64	Valve screw	1
22	Hinge pin	1	65	Oil reservoir	1
23	Compression spring	1	66	Magnetic bar	1
24	Locating screw	1	67	Filler cap	1
25	Main piston	1	69	Fibre glass pipe	1
26	Back-up ring	1	70	Handle grip	1
27	O-ring	1	71	Insulation cap	1
28	Valve screw	2	72	Cap	1
29	Compression spring	2	73	Spring pin	1
30	Ball	2	74	Hinge pin	1
31	Cylinder body	1	75	Bushing	4
32	Compression spring	1	76	Crescent	2
34	Pump piston	1	77	Arresting pin	1
35	Back-up ring	1	78	Conical pin	1
36	O-ring	1	79	Torsional spring	1
37	O-ring	1	80	Guide bolt	1
38	Back-up ring	1	81	Release pin	1
39	Locating screw	1	82	Fibre glass pipe	1
40	Release valve stem	1	83	Spring pin	1
41	O-ring	1	84	Handle grip	1
42	Relief valve set	1	85	Washer	1
43	Compression spring	1			

Serial number and model need to be quoted when ordering parts.