



Instruction Manual

Remote Hydraulic Cutter
Model – HC-55R



Maximum Operating Pressure – 700 bar



This is a safety alert symbol. It is used to alert you to potential personal injury hazards. Obey all safety messages that follow this symbol to avoid injury or death

1.0 Product Information

DURAPAC – Hydraulic cutters are engineered to meet Industrial Standards for Performance and Safety. The HC-55R is a remote cutter that is compact, lightweight, easy to use and supplied in a heavy-duty canvas carry bag. They feature:

- Single-action cylinder with spring return
- Flip-top latch for easy insertion of cutting material
- Operated by 700 bar / 10,000 psi rated hydraulic pump
- Blades are easily replaceable

The HC-55R cuts with ease though soft steel bar, wire rope, reinforcing rod, copper, aluminium, ACSR and guy wire. It is a proven performer in the electrical, railway, mining, manufacturing and construction industries.

Note – this tool is not designed to cut CCP cable or piano wire.

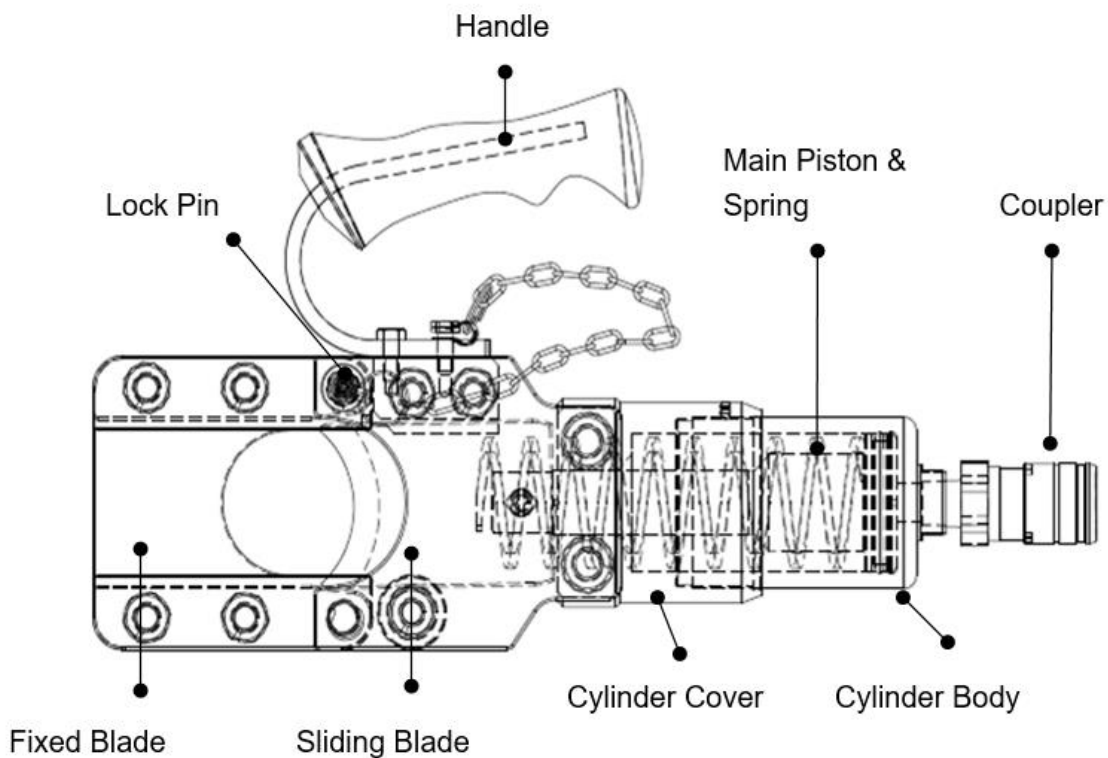

Figure 1 – HC-55R Subassembly

Special skill, knowledge and training may be required for a specific task and the product may not be suitable for all jobs. The user must ultimately make the decision regarding suitability of the product for any given task and assume the responsibility of safety for all in the work area. Contact a Durapac representative if you are unsure of your hydraulic cutter’s suitability for a particular application.

2.0 Receiving Instructions

It is recommended prior to use that an inspection be done by qualified personnel and that any missing or damaged parts, decals, warning/safety labels or signs are replaced with Durapac authorised replacement parts only. Any hydraulic cutter that appears to be damaged in any way, is worn, leaking or operates abnormally should be removed from service immediately until such time as repairs can be made. Any hydraulic cutter that has been or suspected to have been subject to a shock load should be removed from service immediately until inspected by a Durapac authorised service centre. Owners and operators of this equipment should be aware that the use and subsequent repair of this equipment may require specialised training and knowledge.

3.0 Safety

Save these instructions. For your safety, read and understand the information contained within. The owner and operator should understand this product and safe operating procedures before attempting to use this product. Instructions and safety information should be conveyed in the operator's native language before use of this product is authorised. Make certain that the operator thoroughly understands the inherent dangers associated with the use and misuse of the product. If any doubt exists as to the safe and proper use of this product as outlined in this factory authorised manual, remove from service immediately.



DANGER:

- To avoid personal injury keep hands and feet away from work area during operation
- **Do NOT** handle pressurised hoses. Escaping oil under pressure can penetrate the skin causing serious injury. If oil is injected under the skin, see a doctor immediately



WARNING:

- The system operating pressure must not exceed the pressure rating of the lowest rated component in the system. Install pressure gauges in the system to monitor operating pressure. It is your window to what is happening in the system
- Always wear appropriate *personal protective equipment (PPE)* when operating hydraulic equipment. The operator must take precaution against injury due to failure of the tool or work piece(s)
- **Do NOT** hold or stand directly in line with any hydraulic connections while pressurising
- **Do NOT** attempt to disconnect hydraulic connections under pressure. Release all line pressure before disconnecting hoses



IMPORTANT:

- If at any stage, the safety related decals become hard to read, these must be replaced
- Minimum age of the operator must be 18 years. The operator must have read and understood all instructions, safety issues, cautions and warnings before starting to operate the equipment. The operator is responsible for this activity towards other persons
- **Do NOT** lift hydraulic equipment by the hoses or couplers. Use the carrying handle or other means of safe transport

- Hydraulic equipment must only be serviced by a qualified hydraulic technician. For repair service, contact the Durapac authorised service centre in your area. To protect your warranty, use only high-quality hydraulic oil

**CAUTION:**

- **KEEP HYDRAULIC EQUIPMENT AWAY FROM FLAMES AND HEAT.** Hydraulic fluid can ignite and burn. Excessive heat will soften packings and seals, resulting in fluid leaks. Heat also weakens hose materials and packings. For optimum performance do not expose equipment to temperatures of 65°C (150°F) or higher. Protect all equipment from weld spatter
- No alteration should be made to this device
- Keep the area around the equipment clean and free of obstructions
- Bystanders should stay clear of the work area
- Stay alert while using hydraulic equipment. **Do NOT** operate while under the influence of drugs, alcohol or medicine
- **Do NOT** wear loose hair or clothes that may get caught in the equipment

3.1 Hydraulic Cutters

- **Do NOT** attempt to disassemble or repair this product. Repairs should be done by a qualified Durapac repair agent.
- This product is **NOT** an insulator. Proper equipment should be used to avoid electrical shock
- **Do NOT** drop tool onto the ground or into the carrying case
- **Do NOT** keep this product in places with high temperatures, high humidity or direct sunlight
- Suggested working temperatures -10°C to 40°C
- Hydraulic fluid temperatures over 65°C might cause damage to components sealed inside the product

3.2 Hydraulic Hoses & Fluid Transmission Lines

- Avoid short runs of straight-line tubing. Straight line runs do not provide for expansion and contraction due to pressure and/or temperature changes
- Reduce stress in tube lines. Long tubing runs should be supported by brackets or clips. Before operating the pump, connections should be tightened securely and leak-free. Over tightening can cause premature thread failure or high-pressure fittings to burst
- Should a hydraulic hose ever rupture, burst or need to be disconnected, immediately shut off the pump and release all pressure. Never attempt to grasp a leaking pressurised hose with your hands. The force of escaping hydraulic fluid can inflict injury
- **Do NOT** subject the hose to potential hazard such as fire, sharp objects, extreme heat or cold or heavy impact

- **Do NOT** allow the hose to kink, twist, curl, crush, cut or bend so tightly that the fluid flow within the hose is blocked or reduced. Periodically inspect the hose for wear
- Hose material and coupler seals must be compatible with the hydraulic fluid used. Hoses also must not come in contact with corrosive materials such as battery acid, creosote-impregnated objects and wet paint. Never paint a coupler or hose

FAILURE TO HEED THESE WARNINGS MAY RESULT IN PERSONAL INJURY AS WELL AS PROPERTY DAMAGE.

4.0 Installation

- 4.1 Familiarise yourself with the specifications and illustrations in this owner’s manual. Know your hydraulic cutter, its limitations and how it operates before attempting to use. Refer to the Specification and Cutting Capacity tables below or if in doubt, contact a Durapac representative.

Model Number	Max. Pressure (bar)	Oil Required (cc)	Max. Output (kN)	Cylinder Stroke (mm)	Length (mm)	Weight (kg)
HC-55R	700	107	146.3	55.6	415	8.4

Wire Rope (mm)			Soft Steel Bar (mm)	Reinforcing Rod (mm)	Soft Copper Bar (mm)	Soft Aluminium Bar (mm)	ACSR (mm)	Underground Cable (mm)	Cu Strands (mm)	Al Strands (mm)	Guy Wire (mm)	
6x7	6x12	6x19									1x7	1x19
25	30	30	22	19	24	18	50	24	50	50	15	20

Cutting of piano wire is not recommended

- 4.2 Check oil level in reservoir before operating cutter.
- 4.3 Remove air from the system by operating the pump to advance and retract the sliding blade several times.

5.0 Operation



IMPORTANT:

- The maximum cutting capacity of this tool **includes** the thickness of the cable covering. Keep this in mind when selecting the appropriate cable to use. If in doubt, use another tool to cut away the cable covering before commencing cutting with this tool
- Only attempt to cut cables which fit the tool specifications. No other materials are to be cut
- Inspect the tool before and after every use. **Do NOT** use this tool if damaged in any way

5.1 Before Operation

- 5.1.1 Make sure all parts of the product are clean, without rust or loose parts.
- 5.1.2 Ensure the hydraulic pump and hose are working properly and rated at 700 bar (10,000 psi).

- 5.1.3 Check that no leakage occurs while the tool is resting or while the product is being tested without cables.
- 5.1.4 Hydraulic pressure should be able to reach 700 bar (10,000 psi) while tested without cables.
- 5.1.5 Connect the cutting head coupler to the hose coupler and pump. Firmly tighten couplers to prevent restricted oil flow.
- 5.1.6 To remove air trapped in the hydraulic system, operate the pump to advance and retract the sliding blade several times.

5.2 Operation

- 5.2.1 Retract the piston and the blade. The tool is now ready to operate.
- 5.2.2 Pull out the *Arresting Lever* (#22) and pull back the upper blade to open the cutting head.
- 5.2.3 Place the cable between the blades and close the cutting head. The *Arresting Lever* must be fully inserted before operating (see below).

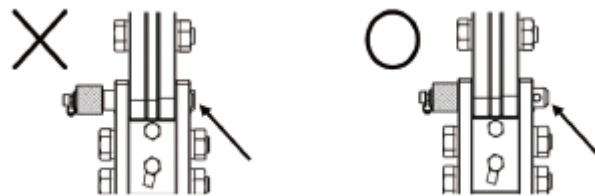

Figure 2 – Arresting Lever Position

- 5.2.4 Position the cable in the **centre** of the fixed blade. Improper positioning of the cable on the edge might cause damage to the blade or deform the tool.

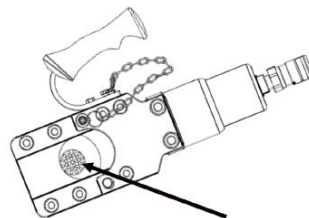

Figure 3 – Centre cable

- 5.2.5 Hold the cable and cutter head in position. Operate the pump to advance the sliding blade. Ensure the cable is at a 90° angle to the cutter blades.
- 5.2.6 The operation is complete when the hydraulic pressure reaches 700 bar (10,000 psi) and the safety relief valve is activated.
- 5.2.7 Retract the blade by releasing the oil pressure to release the oil back to the pumping source.

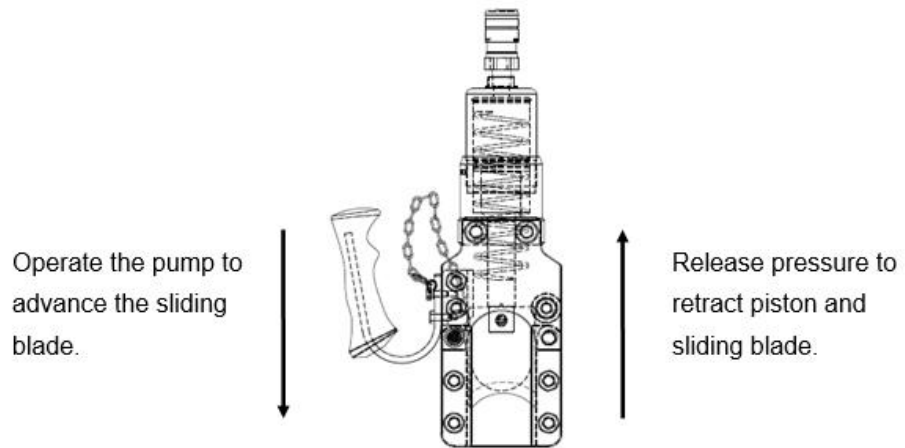

Figure 4 – Release Pressure

- 5.2.8 Repeat steps 5.2.1 – 5.2.7 until all cuts are completed.
- 5.2.9 Retract the tool head blade completely before turning off the pumping source.
- 5.2.10 Dismount the couplers. If the couplers cannot be dismounted, restart the pump to release the internal pressure. Replace dust caps on the couplers.

5.3 After Operation

- 5.3.1 Clean the product and blades.
- 5.3.2 Ensure all components are in working condition.
- 5.3.3 Ensure cylinder piston is fully retracted.
- 5.3.4 Apply rust preventive oil to the product and blades before returning it to the carrying case for storage.

6.0 Maintenance



IMPORTANT:

- **Do NOT disassemble or attempt to repair this tool.** Equipment must only be serviced by a qualified hydraulic technician. For repair service, contact your local Durapac authorised service centre
- Disconnect power supply and release pressure before cleaning the tool head or pump
- Check oil level regularly and make sure the reservoir is full
- Use only good quality hydraulic fluid. **Do NOT** use brake fluid, transmission fluid, turbine oil, motor oil, alcohol, glycerine etc. Use of anything other than good quality hydraulic oil will void warranty and damage the cutter. We recommend Durapac Hydraulic Oil or equivalent
- Tools with worn or damaged blades may cause property damage or even personal injury

Maintenance is required when wear or leakage is noticed. Periodically inspect all components to detect any problem that may require service and maintenance.

Keep the tool head free of dirt and metal chips. Use a lubricant to clean the tool when necessary.

Routine application of rust preventative oil to the product is needed. Avoid bringing the tool into contact with water or solvents.

Routine renewal of pump oil is required. Particles mixed in the pump oil may cause malfunction or damage to the product.

Cutter blades may need to be replaced. Follow the instructions below:

6.1 Blade Replacement

6.1.1 Fixed Blade Replacement

6.1.1.1 Open the tool head and pull back the fixed blade. Remove the *Hinge Pin* (#15) and the (4) *Hex Nut* (#30) to unfasten the fixed blade.

6.1.1.2 Position the new blade. Reassemble the hinge pin and screws.

6.1.1.3 Ensure that all components are tight and that the blade opens and closes smoothly.

6.1.2 Moving Blade Replacement

6.1.2.1 Open the tool head and pull back the upper blade. Use the pump source to advance the moving blade until the *Locating Screw* (#13) on the piston is accessible.

6.1.2.2 Remove the *Locating Screw* to unfasten the blade.

6.1.2.3 Insert the new blade and reassemble the *Locating Screw* to secure the blade in place.

6.1.2.4 Ensure that all components are tight and the blades open and close smoothly before attempting to cut any cables.

6.2 Storage

6.2.1 Check to ensure that all pieces are in good working condition.

6.2.2 Apply rust preventive oil to the product and blades before returning tool to the carrying case.

7.0 Troubleshooting

Problem	Cause	Solution
Cable cannot be cut	Worn or damaged blades	<ul style="list-style-type: none"> Replace blades
	Cables are over specification	<ul style="list-style-type: none"> Use tool that is appropriate for cutting requirements
	Internal leakage	<ul style="list-style-type: none"> Send to a Durapac authorised service centre for repair
Insufficient operating pressure	Pressure loss	<ul style="list-style-type: none"> Inspect pump output

Problem	Cause	Solution
		<ul style="list-style-type: none"> • Tighten couplers to prevent restricted oil flow
Sliding blade is jammed or unable to retract after operation	Worn or damaged blades	<ul style="list-style-type: none"> • Replace blades
	Blade guide pieces are blocked with impediments	<ul style="list-style-type: none"> • Use an airgun to remove impediments • Use lubricant to clean the tool
Lock pin cannot be set in place or removed	Sliding blade or fixing blade has been damaged	<ul style="list-style-type: none"> • Send to a Durapac authorised service centre for repair
	Lock pin is deformed	<ul style="list-style-type: none"> • Send to a Durapac authorised service centre for repair

8.0 Parts Breakdown and List

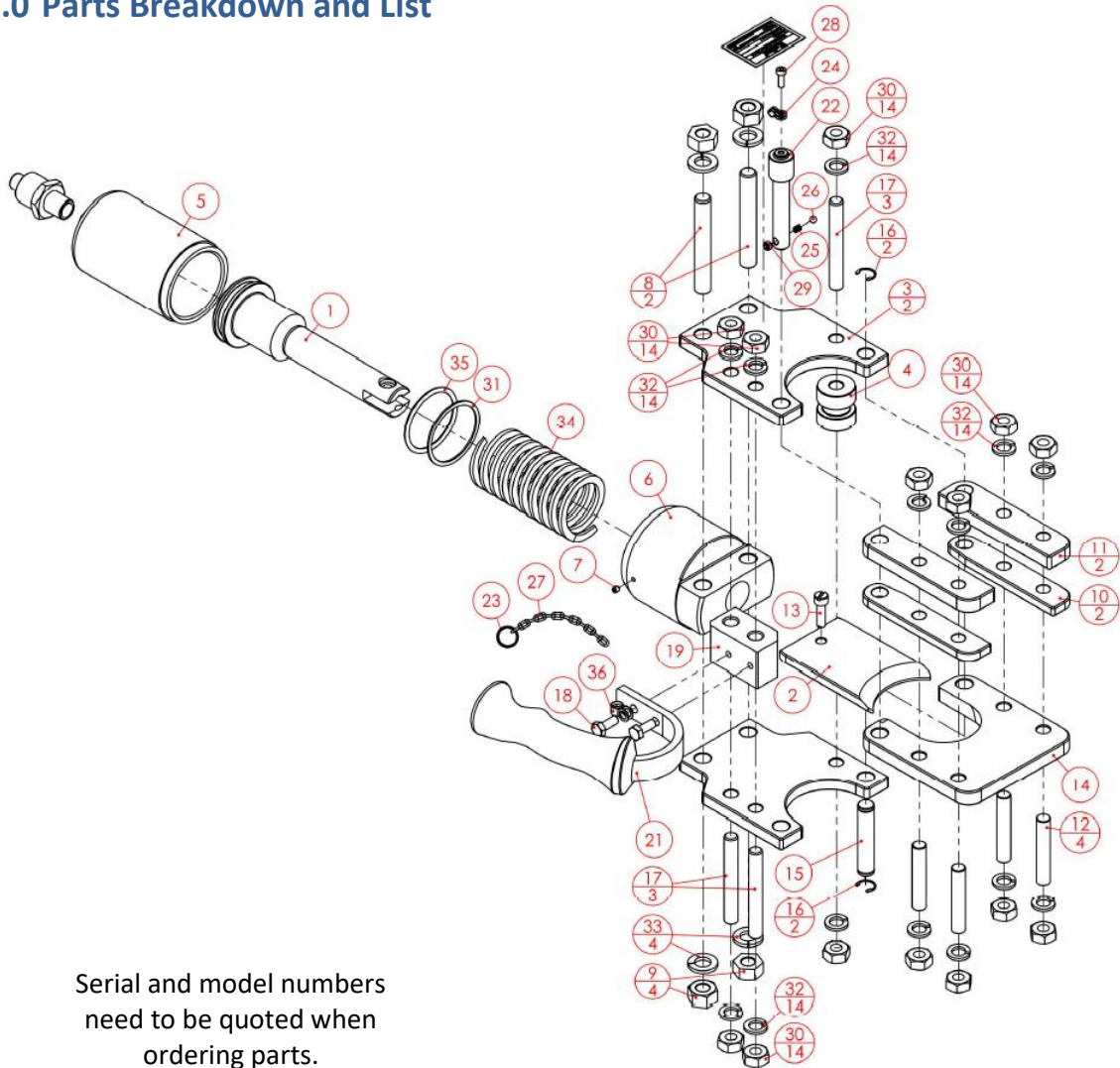

Serial and model numbers need to be quoted when ordering parts.

Item	Description	Qty	Item	Description	Qty
1	Main piston	1	19	Locating block	1
2	Moving blade	1	21	Handle with grip	1
3	Support plate	2	22	Arresting lever	1
4	Roller	1	23	Ring	1
5	Cylinder	1	24	Buckle	1
6	Cylinder cover	1	25	Compression spring	1
7	Screw	1	26	Ball	1
8	Stud bolt	2	27	Chain	1
9	Hex. nut	4	28	Screw	1
10	Blade guide	2	29	Screw	1
11	Blade guide	2	30	Hex. Nut	14
12	Stud bolt	4	31	Back-up ring	1
13	Locating screw	1	32	Spring washer	14
14	Fixed blade	1	33	Spring washer	4
15	Hinge pin	1	34	Compression spring	1
16	Crescent	2	35	O-ring	1
17	Stud bolt	3	36	Buckle	1
18	Screw	2			