

DURAPAC

ENGINEERED FOR RELIABILITY

Instruction Manual

Battery Power Unit
Model – DBP-120M



Maximum Operating Pressure – 700 bar



This is a safety alert symbol. It is used to alert you to potential personal injury hazards. Obey all safety messages that follow this symbol to avoid injury or death

1.0 Product Information

DURAPAC – Battery Power Units are engineered to meet Industrial Standards for Performance and Safety. The DBP-120M battery driven hydraulic power unit will power single-acting cylinders and tools. Ideal for operating hydraulic crimpers, cutters, and cylinders for jacking, spreading, and pushing applications. The standard power unit includes a remote pendant, 2 x 18 V batteries, charger, and a shoulder strap. A wireless remote pendant is also available, for cable spiking and other applications where a wireless remote is preferred.

Features:

- Operates with powerful, high-capacity Li-ion batteries featuring individual capacity detection for A and B batteries
- OLED display for pump pressure and battery capacity
- Onboard storage for both Batteries & Remote Control
- Maintenance warning alerts
- Buzzer alert if action is incomplete / failed & losing pressure
- Mode selection for different applications
- Emergency pressure release button

Inclusions:

- Battery-hydraulic power unit
- 2 x MAKITA 18 V Lithium-ion Batteries
- Battery Charger
- Shoulder strap
- Remote Control



Special skill, knowledge and training may be required for a specific task and the product may not be suitable for all jobs. The user must ultimately make the decision regarding suitability of the product for any given task and assume the responsibility of safety for all in the work area. Contact a Durapac representative if you are unsure of your power unit's suitability for a particular application.

2.0 Receiving Instructions

It is recommended prior to use that an inspection be done by qualified personnel and that any missing or damaged parts, decals, warning/safety labels or signs are replaced with Durapac authorised replacement parts only. Any power unit that appears to be damaged in any way, is worn, leaking or operates abnormally should be removed from service immediately until such time as repairs can be made. Any power unit that has been or suspected to have been subject to a shock load should be removed from service immediately until inspected by a Durapac authorised service centre. Owners and operators of this equipment should be aware that the use and subsequent repair of this equipment may require specialised training and knowledge.

3.0 Safety

Save these instructions. For your safety, read and understand the information contained within. The owner and operator should understand this product and safe operating procedures before attempting to use this product. Instructions and safety information should be conveyed in the operator's native language before use of this product is authorised. Make certain that the operator thoroughly understands the inherent dangers associated with the use and misuse of the product. If any doubt exists as to the safe and proper use of this product as outlined in this factory authorised manual, remove from service immediately.

**DANGER:**

- To avoid personal injury, keep hands and feet away from work area during operation
- **Do NOT** handle pressurised hoses. Escaping oil under pressure can penetrate the skin causing serious injury. If oil is injected under the skin, see a doctor immediately
- Stay clear of loads supported by hydraulics. A cylinder, when used as a load lifting device, should never be used as a load holding device. After the load has been raised or lowered, it must always be supported mechanically

**WARNING:**

- The system operating pressure must not exceed the pressure rating of the lowest rated component in the system. Install pressure gauges in the system to monitor operating pressure. It is your window to what is happening in the system
- Always wear appropriate personal protective equipment (PPE) when operating hydraulic equipment. The operator must take precaution against injury due to failure of the tool or work piece(s)
- **Do NOT** hold or stand directly in line with any hydraulic connections while pressurising
- **Do NOT** attempt to disconnect hydraulic connections under pressure. Release all line pressure before disconnecting hoses
- All personnel must be clear before lowering load or depressurising the system
- **Do NOT** attempt to lift a load weighing more than the capacity of the cylinder

**IMPORTANT:**

- If at any stage, the safety related decals become hard to read, these must be replaced
- Minimum age of the operator must be 18 years. The operator must have read and understood all instructions, safety issues, cautions and warnings before starting to operate the equipment. The operator is responsible for this activity towards other persons
- **Do NOT** lift hydraulic equipment by the hoses or couplers. Use the carrying handle or other means of safe transport
- Hydraulic equipment must only be serviced by a qualified hydraulic technician. For repair service, contact the Durapac authorised service centre in your area. To protect your warranty, use only high quality hydraulic oil

**CAUTION:**

- **KEEP HYDRAULIC EQUIPMENT AWAY FROM FLAMES AND HEAT.** Hydraulic fluid can ignite and burn. Excessive heat will soften packings and seals, resulting in fluid leaks. Heat also weakens hose materials and packings. For optimum performance do not expose equipment to temperatures of 65°C (150°F) or higher. Protect all equipment from weld spatter
- No alteration should be made to this device

3.1 Hydraulic Power Units

- When power tools are used, basic safety precautions must be followed to prevent the risks of fire, electric shock and personal injury
- The pump has a high oil flow rate. This results, especially when driving small tools (diameter of the working piston), high speeds of the working piston. The operator must take suitable protective measures to ensure safe operation of the tools with this power unit
- **Do** use a gauge or other load measuring instrument to verify load
- **Do NOT** exceed the rated capacity of the power unit or any equipment in the system. Burst hazard exists if connection pressure exceeds rated pressure
- **Do NOT** operate the system with bent or damaged couplers or damaged threads
- **Do NOT** subject the power unit and its components to shock loads
- Use only Durapac approved accessories and components
- **Do NOT** connect to an application which can return more oil to the reservoir than the power unit reservoir can hold
- **Do NOT** connect power unit to a hydraulic system that is powered by another pump

3.2 Hydraulic Hoses & Fluid Transmission Lines

- Avoid short runs of straight line tubing. Straight line runs do not provide for expansion and contraction due to pressure and/or temperature changes
- Reduce stress in tube lines. Long tubing runs should be supported by brackets or clips. Before operating the power unit, connections should be tightened securely and leak-free. Over tightening can cause premature thread failure or high pressure fittings to burst
- Should a hydraulic hose ever rupture, burst or need to be disconnected, immediately shut off the power unit and release all pressure. Never attempt to grasp a leaking pressurised hose with your hands. The force of escaping hydraulic fluid can inflict injury
- **Do NOT** subject the hose to potential hazard such as fire, sharp objects, extreme heat or cold or heavy impact

- **Do NOT** allow the hose to kink, twist, curl, crush, cut or bend so tightly that the fluid flow within the hose is blocked or reduced. Periodically inspect the hose for wear
- Hose material and coupler seals must be compatible with the hydraulic fluid used. Hoses also must not come in contact with corrosive materials such as battery acid, creosote-impregnated objects and wet paint. Never paint a coupler or hose

FAILURE TO HEED THESE WARNINGS MAY RESULT IN PERSONAL INJURY AS WELL AS PROPERTY DAMAGE.

4.0 Installation



IMPORTANT:

- The power unit is connected by means of a quick coupling via a corresponding pressure hose
- In the event of a fault in the electronic control, the system pressure of the electric pump is limited by a safety pressure relief valve
- The pump cannot be operated without batteries or with defective batteries. Completely discharged batteries must first be fully charged before the pump can be operated

4.1 Familiarise yourself with the specifications and illustrations in this owner’s manual. Know your power unit, its limitations and how it operates before attempting to use. Refer to the technical data below or if in doubt, contact a Durapac representative.

Model Number	Min. Oil Flow @ (L/min)		Oil Capacity (cc)	Pressure Rating (bar)	Battery (Volt/Ah)	Control Switch	Dimensions W x L x H (mm)	Weight with 2 x Batteries [^] (kg)	Weight without Battery (kg)
	Low Pressure	High Pressure							
DBP-120M	1.6	0.36	1,500	700	18 / 4.0	Onboard Switch or Remote Pendant ⁺	203 x 280 x 330	9.0	7.5

⁺ Optional Wireless Remote Pendant available

[^] Add 0.2 kg for Standard Remote & 0.35 kg for both Remotes

4.2 Strap Installation

Step	Action
1.	Hook the strap ring into the hook ring on the handle.
2.	Hook the strap ring into the hook ring under the functional knob.
3.	Check the strap is attached securely to the battery-hydraulic pump.

Figure 1 – Strap Installation

- 4.3 Power Unit - Ensure power unit is turned off and is on a firm, stable, level surface. If the pump is operated in an elevated position (> 0.5m above ground), it must be secured against falling. Please note that the hydraulic hose may cause pulling forces on the pump.
- 4.4 Oil - Your cordless electrohydraulic pump comes ready to use. The pump is filled with oil and can be used immediately. If the oil is supplied separately, the power unit must be filled with oil before starting.
- 4.5 Remote Control – The unit is supplied with a corded remote pendant. An optional wireless remote is also available. Operation is the same for both.
- 4.6 Connect the hydraulic tool to the quick coupling - To connect the tool to the quick coupling, first remove the protective cap.
 **ATTENTION** - Make sure that the coupling is only coupled in a depressurised condition.
- 4.7 After uncoupling the tool, always put on the cap. The couplings must be clean when plugged in, as introduced dirt particles can damage the pumping elements.
- 4.8 Before uncoupling the hose and tool, always return the working piston of the tools to their initial positions. As a result, the oil flows back from the tool cylinder into the pump. This prevents oil loss of the pump.

5.0 Operation



IMPORTANT:

- Remove batteries before exchanging or cleaning the tool head
- Always monitor pressure, load or position using suitable equipment. Pressure may be monitored by means of an optional manifold and gauge. Correct application position can only be determined by the operator of the equipment
- If sustained, positive load holding is required for a particular application, consider a load holding valve such as the Durapac VCV-66
- **Do NOT** operate a power unit that is disconnected from the application. If operated in this condition, the hose and connections will become pressurised. This increases the chance of a burst hazard. Damage may also occur to the power unit and its components
- Before each operation, the operator must make sure that the power unit is in perfect condition, in particular the pressure hose, the plug-in connectors and the connected tool

5.1 Operational Control Options

Move Switch Forward to Advance & Backwards to Retract for all three Control options.

Note – For safety, when Corded or Wireless Remote Control is connected, the Onboard Control switch is no longer operational

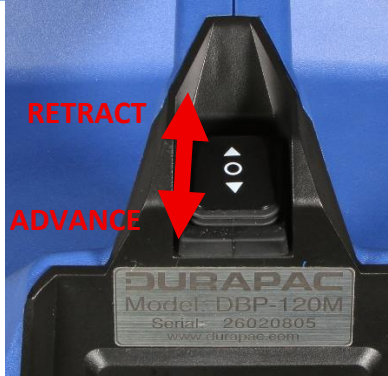
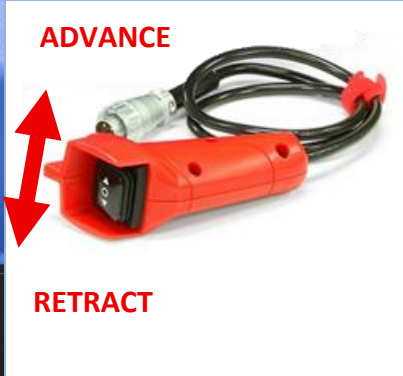
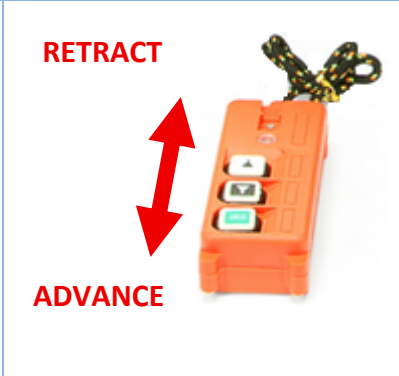
Onboard Control	Corded Remote Control	RF Wireless Remote Control (opt.)
		
<p>Located above the Durapac label and model number on power unit.</p>	<p>Plug in the back of the power unit, just below the battery area. Store in the storage cavity.</p> <p>Battery of Remote needs replacing if the LED on the Remote flashes red.</p>	<p>See 5.3 RF Wireless Remote Operation for details.</p> <p>Battery of Remote needs replacing if the LED on the Remote flashes red.</p>

5.2 Mode Selection

No.	Mode	Action
1.	Power off	
2.	Auto Retract	Cylinder will hold pressure up to max. pressure & auto-retract once max. pressure is reached.
3.	Pressure Hold	Cylinder will hold pressure.
4.	Hold	Press the retract button to retract the cylinder.
5.		
6.	Usage Count	Usage count of the unit display.
7.	RF Wireless Remote	The wireless symbol  will be displayed on the LED screen. Press the Advance button on the Remote to select “Y” to activate the wireless function.

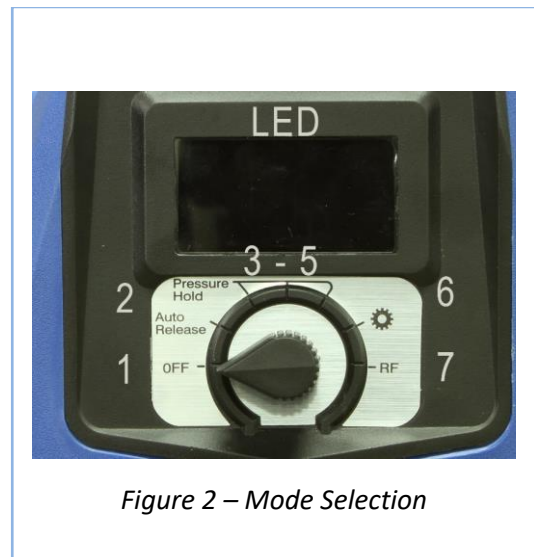

5.3 RF Wireless Remote Operation

- ⚠ The range of the RF Wireless Remote is approximately 10 meters.
- ⚠ Battery of Remote needs replacing if the LED on the Remote flashes red.

The wireless symbol  will be displayed on the LED screen. Press the Advance button on the Remote to select “Y” to activate the wireless function.

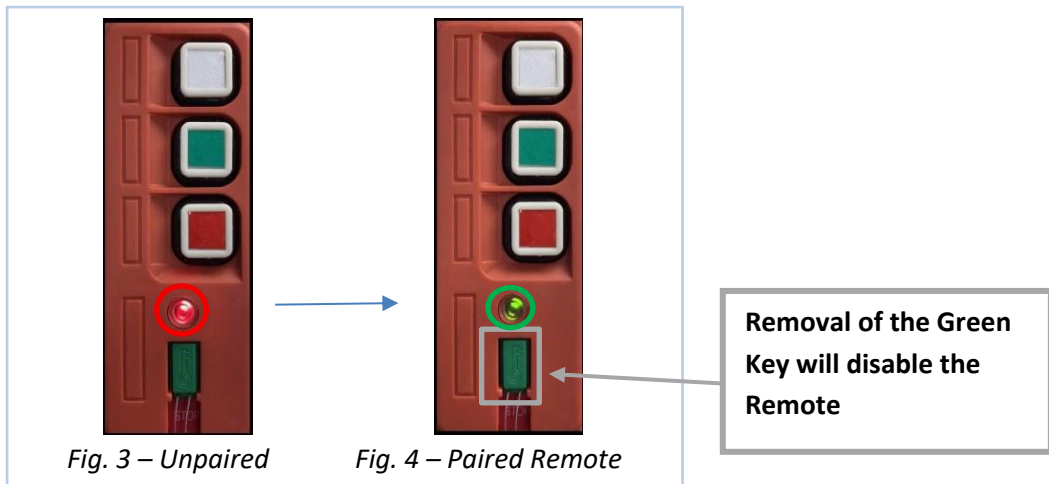

Button	Action
White	To pair the Remote to the Unit, press the White button on the Remote for 3~5 seconds. Red light = Unpaired Green light = Paired/Connected
Green	Advance
Red	Retract

5.4 Battery Capacity Level

The system counts a work time when the pressure is over 200 bar. When the pump count exceeds 5,000, an alert will pop up to remind users of maintenance process.

5.5 Battery Removal / Installation

- ⚠ **Do not** open or attempt to repair the battery cartridge
- 5.5.1 To remove battery, press on the battery latch and slide battery up.
- 5.5.2 To install battery, slide battery into the contacts until it clicks into place. The batteries should be secure and unable to be moved.



Note - Follow battery disposal guidelines

5.6 Battery Charging

- 5.6.1 Plug the AC charger plug into the wall socket. Ensure the electrical outlet meets the charger's specifications.
- 5.6.2 Position the battery cartridge into the battery charger. The LED indicator light will go out when the battery is fully charged.

6.0 Maintenance



IMPORTANT:

- Check oil level regularly
- Remove batteries and release pressure before exchanging or cleaning the tool head, cleaning the unit, or changing hydraulic oil
- Use only good quality hydraulic fluid. **Do NOT** use brake fluid, transmission fluid, turbine oil, motor oil, alcohol, glycerine etc. Use of anything other than good quality hydraulic oil will void warranty and damage the power unit, hose, and application. We recommend Durapac Hydraulic Oil or equivalent. Some applications such as cable spiking require special oils. Refer to your authorised distributor for details
- Equipment must only be serviced by a qualified hydraulic technician. For repair service, contact your local Durapac authorised service centre
- Damage to hydraulic hoses may not be detected during visual inspections. For this reason, Durapac recommends that hydraulic hoses be replaced on a regular basis
- Tighten connections as needed. Use non-hardening pipe thread compound when servicing connections
- Unused devices should be switched off, kept in a dry, locked place and out of the reach of children
- The electrical equipment may only be maintained by a recognized electrician
- Do not manipulate the pump, remove parts or replace them with foreign parts

Dirt, sand, etc. will quickly ruin any hydraulic system. Ensure that couplings are clean and free of foreign matter. After each use, clean couplings and attach dust caps.

Maintenance is required when wear or leakage is noticed. Periodically inspect all components to detect any problem that may require service and maintenance.

6.1 Adding Hydraulic Fluid

- ⚠ **WARNING:** Always add oil with cylinders fully retracted (or extended, if pull cylinders) or the system will contain more oil than the reservoir can hold
- ⚠ The pump is delivered, filled with oil to approx. 1,500 cc
- ⚠ The pump has a closed oil circulation system. If the operated tools are properly returned to their original position after use, the oil level should only need to be checked once per year as part of the annual safety test

- 6.1.1 Depressurise and disconnect hydraulic hose from application/cylinder.
- 6.1.2 Remove batteries – see **5.3 Battery Removal** for details
- 6.1.3 With the power unit on it's side, remove the air vent plug (see Fig. 6).
- 6.1.4 Use a small funnel to fill the reservoir to 1,500 cc (see Fig. 7).
- 6.1.5 Bleed air from system if necessary.
- 6.1.6 Wipe up any spilled fluid and reinstall the air vent plug.

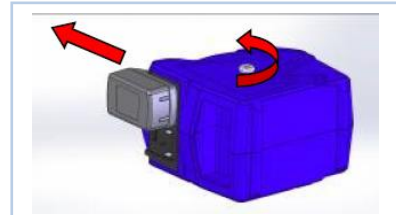

Fig. 6 – Remove Vent Plug



Fig. 7 – Pour in oil

6.2 Bleeding Air from the System

- 6.2.1 Repeat Steps 6.1.1 to 6.1.5 (above), if required.
- 6.2.2 Using a hydraulic hose, open coupling into the reservoir. Operate the pump until a steady stream of air free oil is seen. Disconnect the open coupling and couple to a suitable hydraulic cylinder.
- 6.2.3 Extend and retract the cylinder several times putting a load on the system. Any remaining air will be released into the power unit reservoir.
- 6.2.4 Recheck oil level after removing air.

6.3 Changing Hydraulic Fluid

- ⚠ For best results, change fluid once a year or every 300 hours of use
- ⚠ Depending on the frequency and type of use of the pump, the oil level must be checked, if necessary, top up with oil. Furthermore, the oil should be changed regularly depending on the conditions of use. At least every two years.

- 6.3.1 Repeat Steps 6.1.1 to 6.1.3 (above).
- 6.3.2 Pour used fluid into a sealable container.
- 6.3.3 Repeat Steps 6.1.4 to 6.1.5 (above).
- 6.3.4 Dispose of fluid in accordance with local regulations.

6.4 Maintaining the Battery

Li-ion batteries have a long life if properly maintained. To maximise the service life, please observe the following rules:

- 6.4.1 The battery should be recharged after each use.
- 6.4.2 The battery **must not** be fully discharged.
- 6.4.3 Protect the batteries from high temperatures. Do not store the pump in direct sunlight. Temperatures above 40 ° C will decrease the battery life.

6.5 Storage

- 6.5.1 When not in use, depressurise and disconnect the power unit from the application.
- 6.5.2 Wipe clean thoroughly and store in a clean, dry environment. Avoid temperature extremes.
- 6.5.3 For transportation or long storage, replace the air vent plug with shipping plug.
- 6.5.4 Shield power unit with a protective cover.

7.0 Troubleshooting

Problem	Cause	Solution
Unit starts, but shuts off immediately	High pressure hose not connected correctly	<ul style="list-style-type: none"> • Check quick coupling •
The unit does not start when the button is pressed	Battery of the wireless remote-control is empty	<ul style="list-style-type: none"> • Replace wireless remote-control battery
	No connection of the remote-control cable	<ul style="list-style-type: none"> • Check remote-control connection
	Hose not connected	<ul style="list-style-type: none"> • Check hose connection
	Battery is empty	<ul style="list-style-type: none"> • Recharge the battery
Unit is running but without sufficient pressure/piston travel is too low	Solenoid valve defective	<ul style="list-style-type: none"> • Contact a Durapac authorised service centre for repair
	Oil quantity is insufficient (tool too large)	<ul style="list-style-type: none"> • Contact a Durapac authorised service centre for repair
The unit works but does not apply pressure	Air in the system	<ul style="list-style-type: none"> • Connect hose and tool to the pump • Turn the pump downwards with the coupling • Run the pump several times • The air will escape into the tank, and it can be worked again • If it occurs more frequently, the unit should be returned for service
	The connected hose is not filled with oil	<ul style="list-style-type: none"> • Please follow the steps in 6.2 – Bleeding Air from the System in the Maintenance Section
Unit seems normal, but shutdown pressure is too low	Pressure limitation is adjusted	<ul style="list-style-type: none"> • Contact a Durapac authorised service centre for repair
The working pressure is not reached, and the battery LED is red	The battery capacity is insufficient	<ul style="list-style-type: none"> • Recharge the battery
Ultimate pressure is reached only very slowly or not at all	Pumping elements defective	<ul style="list-style-type: none"> • Contact a Durapac authorised service centre for repair
	Solenoid valve defective	<ul style="list-style-type: none"> • Contact a Durapac authorised service centre for repair
	Battery is empty	<ul style="list-style-type: none"> • Recharge the battery

8.0 Parts Breakdown and List

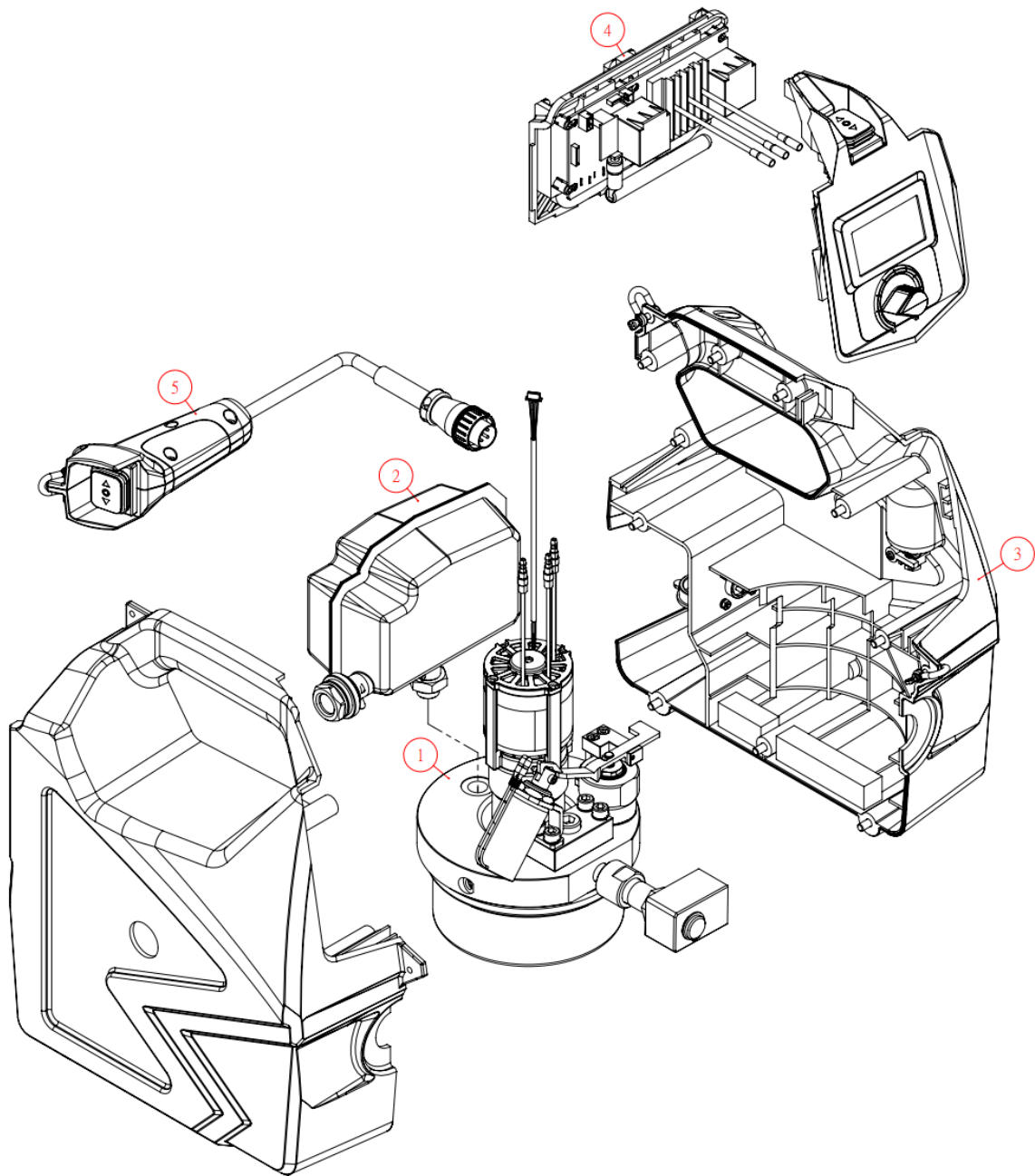

Item	Description	Qty
1	Pump Assembly	1
2	Oil reservoir	1
3	Housing	1
4	Circuit board	1
5	Remote control	1

Serial, model and item numbers need to be quoted when ordering parts.

8.1 Pump Assembly Parts Breakdown and List

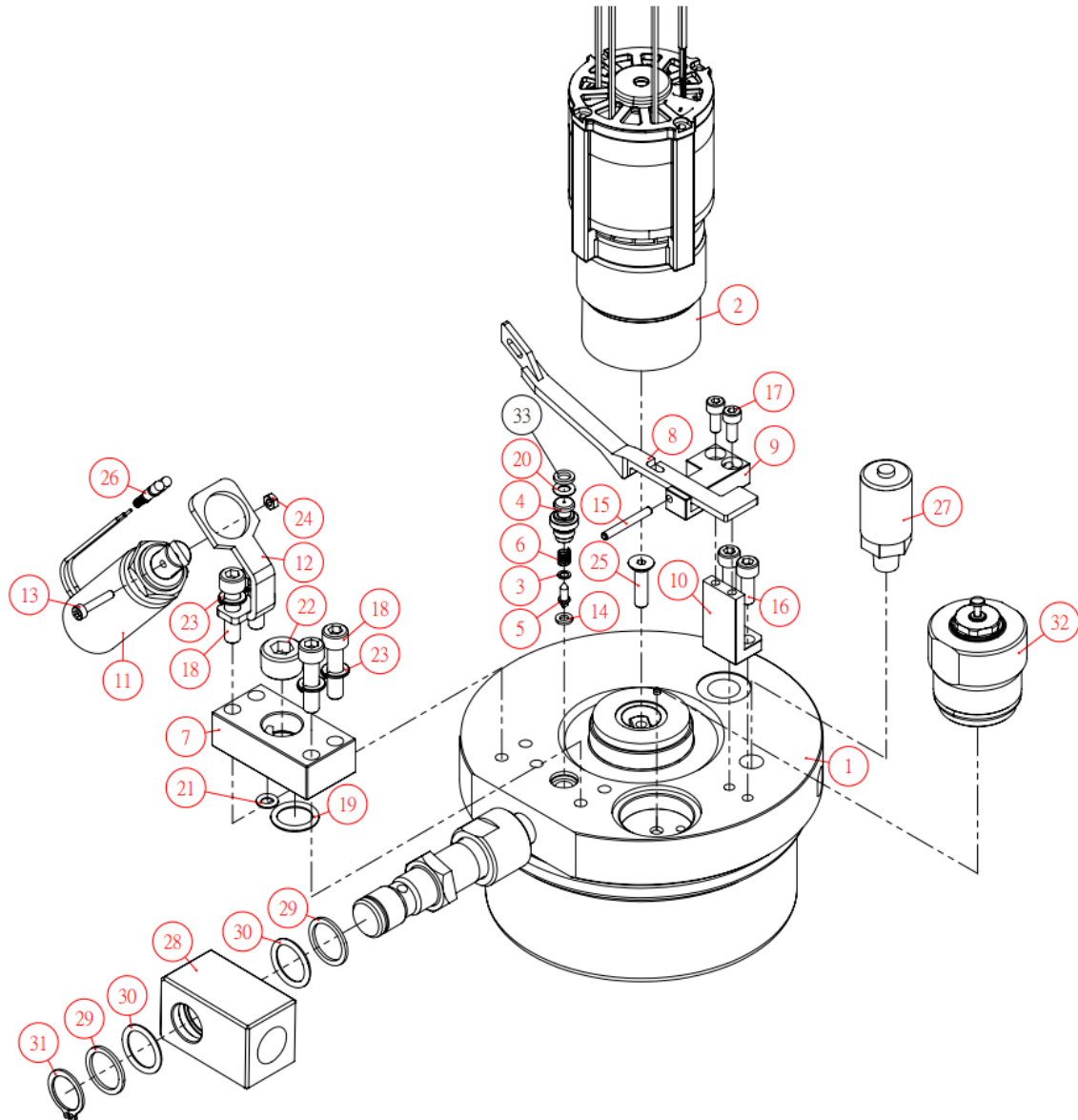

Item	Description	Qty	Item	Description	Qty	Item	Description	Qty
1	Oil duct device	1	12	Magnet stand	1	23	Spring washer	4
2	Motor & gear set	1	13	Screw	1	24	Hex bolt	1
3	Flat washer	1	14	Washer	1	26	Terminal bullet type	2
4	Relief valve set	1	15	Spring	1	27	Pressure sensor	1
5	Relief pin	1	16	Screw	2	28	Swivel coupler	1
6	Compression spring	1	17	Screw	2	29	Back-up ring	2
7	Shift valve	1	18	Screw	4	30	O-ring	2
8	Relief frame	1	19	O-ring	1	31	C-clip	1
9	Release lever stand	1	20	O-ring	1	32	Pressure valve set	1
10	Relief stand	1	21	O-ring	1	33	Back-up ring	1
11	Electromagnetic magnet	1	22	Screw	1			

Serial, model and item numbers need to be quoted when ordering parts.