



Instruction Manual

Single Acting Hollow Piston Cylinders
Model – RHS Series



Maximum Operating Pressure – 10,150 psi



This is a safety alert symbol. It is used to alert you to potential personal injury hazards. Obey all safety messages that follow this symbol to avoid injury or death

1.0 Product Information

DURAPAC – Hydraulic Cylinders are engineered to meet ANSI/ASME B30.1 Standards for Performance and Safety. The RHS Series is a single acting, spring return, hollow piston rod cylinder. The hollow piston allows for a rod or cable to be inserted through the entire body length.

These cylinders can be used in tensioning, load testing, bush extracting and maintenance applications. All RHS Series cylinders feature a hard chrome cylinder bore and piston rod for maximum corrosion resistance and a bronze overlay piston bearing area to reduce scoring and increase service life. All cylinders incorporate a bolt-on, removable steel base plate for extra protection.

- Piston rod wiper reduces contaminants
- Hard chrome plated piston rod for maximum corrosion resistance and cylinder life
- Threaded fit smooth saddle to prevent piston rod damage. Optional TSH threaded saddles available
- Gland nut with low friction coating withstands full dead-end loading
- Hard chrome plated bore for maximum corrosion resistance and cylinder life
- Return spring is sized to ensure efficient piston rod return and maximum spring life
- Bronze overlay on piston bearing area reduces side load induced damage and extends cylinder life
- Steel base plate protects base and threaded mounting holes and is removable

Special skill, knowledge and training may be required for a specific task and the product may not be suitable for all jobs. The user must ultimately make the decision regarding suitability of the product for any given task and assume the responsibility of safety for all in the work area. Contact a Durapac representative if you are unsure of your cylinder's suitability for a particular application.

2.0 Receiving Instructions

It is recommended prior to use that an inspection be done by qualified personnel and that any missing or damaged parts, decals, warning/safety labels or signs are replaced with Durapac authorized replacement parts only. Any cylinder that appears to be damaged in any way, is worn, leaking or operates abnormally should be removed from service immediately until such time as repairs can be made. Any cylinder that has been or suspected to have been subject to a shock load should be removed from service immediately until inspected by a Durapac authorized service center. Owners and operators of this equipment should be aware that the use and subsequent repair of this equipment may require specialized training and knowledge.

3.0 Safety

Save these instructions. For your safety, read and understand the information contained within. The owner and operator should understand this product and safe operating procedures before attempting to use this product. Instructions and safety information should be conveyed in the operator's native language before use of this product is authorized. Make certain that the operator thoroughly understands the inherent dangers associated with the use and misuse of the product. If

any doubt exists as to the safe and proper use of this product as outlined in this factory authorized manual, remove from service immediately.

**DANGER:**

- To avoid personal injury, keep hands and feet away from work area during operation
- **Do NOT** handle pressurized hoses. Escaping oil under pressure can penetrate the skin causing serious injury. If oil is injected under the skin, see a doctor immediately
- Stay clear of loads supported by hydraulics. A cylinder, when used as a load lifting device, should never be used as a load holding device. After the load has been raised or lowered, it must always be supported mechanically

**WARNING:**

- The system operating pressure must not exceed the pressure rating of the lowest rated component in the system. Install pressure gauges in the system to monitor operating pressure. It is your window to what is happening in the system
- Always wear appropriate personal protective equipment (PPE) when operating hydraulic equipment. The operator must take precaution against injury due to failure of the tool or work piece(s)
- **Do NOT** hold or stand directly in line with any hydraulic connections while pressurizing
- **Do NOT** attempt to disconnect hydraulic connections under pressure. Release all line pressure before disconnecting hoses
- All personnel must be clear before lowering load or depressurizing the system
- **Do NOT** attempt to lift a load weighing more than the capacity of the cylinder

**IMPORTANT:**

- If at any stage, the safety related decals become hard to read, these must be replaced
- Minimum age of the operator must be 18 years. The operator must have read and understood all instructions, safety issues, cautions and warnings before starting to operate the equipment. The operator is responsible for this activity towards other persons
- **Do NOT** lift hydraulic equipment by the hoses or couplers. Use the carrying handle or other means of safe transport
- Hydraulic equipment must only be serviced by a qualified hydraulic technician. For repair service, contact the Durapac authorized service center in your area. To protect your warranty, use only high-quality hydraulic oil

**CAUTION:**

- **KEEP HYDRAULIC EQUIPMENT AWAY FROM FLAMES AND HEAT.** Hydraulic fluid can ignite and burn. Excessive heat will soften packings and seals, resulting in fluid leaks. Heat also weakens hose materials and packings. For optimum performance do not expose equipment to temperatures of 150°F (65°C) or higher. Protect all equipment from weld spatter
- No alteration should be made to this device

3.1 Hydraulic Cylinders

- **Do NOT** overload equipment. Overloading can cause equipment failure and possible personal injury
- This device is not suitable for use as a support device! As the system load is lifted, use blocking and cribbing to guard against a falling load
- **BE SURE SETUP IS STABLE BEFORE LIFTING LOAD.** Cylinders should be placed on a flat surface that can support the load. Where applicable, use a cylinder base for added stability. Do not weld or otherwise modify the cylinder to attach a base or other support
- Avoid situations where loads are not directly centered on the cylinder piston. Off-center loads produce considerable strain on cylinder and pistons. In addition, the load may slip or fall, causing potentially dangerous results
- Distribute the load evenly across the entire saddle surface. Always use a saddle to protect the piston (if one is provided)
- **USE ONLY RIGID PIECES TO HOLD LOAD.** Carefully select steel or wood blocks that can support the load. Never use a hydraulic cylinder as a shim or spacer in any lifting or pressing application
- **Never** pressurize uncoupled couplers. Only use hydraulic equipment in a coupled system

3.2 Hydraulic Hoses & Fluid Transmission Lines

- Avoid short runs of straight-line tubing. Straight line runs do not provide for expansion and contraction due to pressure and/or temperature changes
- Reduce stress in tube lines. Long tubing runs should be supported by brackets or clips. Before operating the pump, connections should be tightened securely and leak-free. Over tightening can cause premature thread failure or high-pressure fittings to burst
- Should a hydraulic hose ever rupture, burst or need to be disconnected, immediately shut off the pump and release all pressure. Never attempt to grasp a leaking pressurized hose with your hands. The force of escaping hydraulic fluid can inflict injury
- **Do NOT** subject the hose to potential hazard such as fire, sharp objects, extreme heat or cold or heavy impact
- **Do NOT** allow the hose to kink, twist, curl, crush, cut or bend so tightly that the fluid flow within the hose is blocked or reduced. Periodically inspect the hose for wear
- Hose material and coupler seals must be compatible with the hydraulic fluid used. Hoses also must not come in contact with corrosive materials such as battery acid, creosote-impregnated objects and wet paint. Never paint a coupler or hose

FAILURE TO HEED THESE WARNINGS MAY RESULT IN PERSONAL INJURY AS WELL AS PROPERTY DAMAGE.

4.0 Installation

⚠ IMPORTANT: Always secure threaded port connections with high grade, non-hardening pipe thread sealant. Teflon tape can be used if only one layer of tape is used and it is applied carefully, two threads back, to prevent the tape from being introduced into hydraulic system, which could cause jamming of precision-fit parts

⚠ CAUTION: DO NOT allow the piston rod to rotate when installing adaptors. Damage to the spring may prevent piston rod retraction

4.1 Know your cylinder, its limitations and how it operates before attempting to use. If in doubt, contact Durapac.

4.2 Make hydraulic connections; use a pump release valve or a 3-way valve and one hose for single-acting cylinder.

⚠ IMPORTANT: Fully hand-tighten all couplers. Loose coupler connections will block the flow of oil between the pump and the cylinder

4.3 Check all system fittings and connections to be sure they are tight and leak free.

4.4 Check oil level in reservoir before operating pump.

4.5 Remove air from the system – Position the cylinder so that the piston rod is pointed down and the cylinder is lower than the pump. Advance and retract the cylinder several times, avoiding pressure build-up. Air removal is complete when the cylinder motion is smooth.

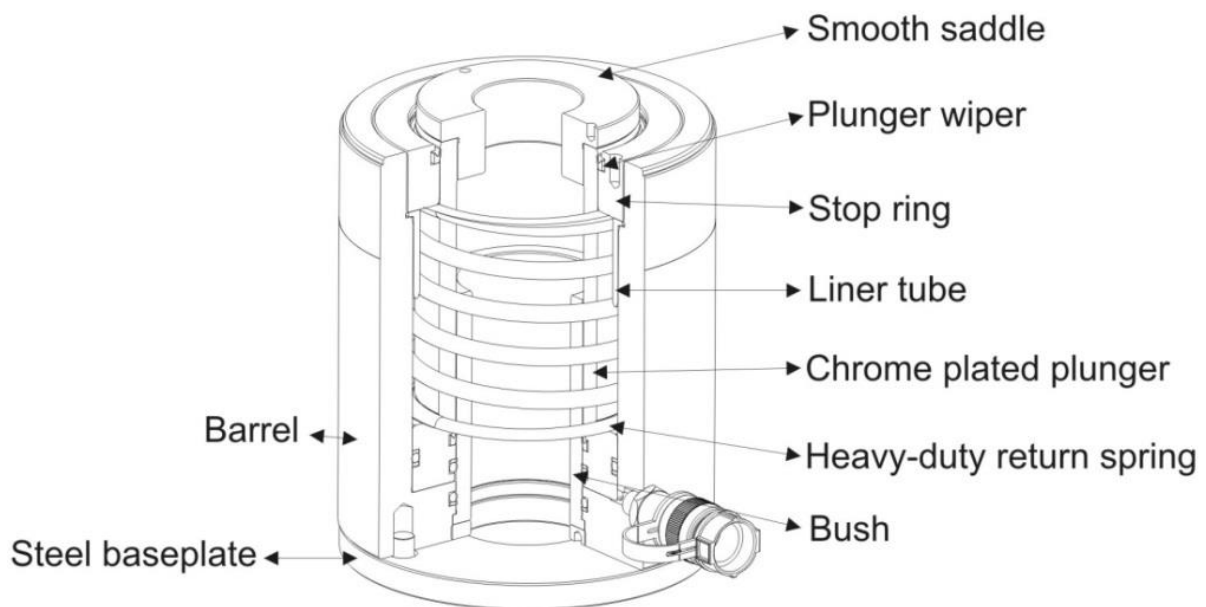

Figure 1 – RHS Series Sectional Drawing

5.0 Operation



IMPORTANT:

- Always use a flat, hard surface as a cylinder support plate
- Collar threads are rated for the full capacity of the cylinder when fully engaged in attachments
- Cylinder gland nut/stop ring is designed to take the full load, to reduce cylinder wear, use less than the full stroke where possible

For complete operating instructions refer to the instruction sheet included with each pump.

5.1 Advancing and retracting the cylinder

The RHS Series cylinders are a spring return cylinder and the speed of retraction is affected by the length of the hose and other restrictions in the line.

Shift the valve on the pump to the advance position and run the pump to advance the cylinder. To retract the cylinder, shift the valve to the retract position.

5.2 Side Load

Eliminate the presence of side load forces when using these cylinders. Side load can occur through:

- 5.2.1 An eccentric load on the piston rod.
- 5.2.2 A horizontal load on a structure.
- 5.2.3 A structure and/or cylinder misalignment.
- 5.2.4 Non synchronized lifting actions.
- 5.2.5 Nonstable cylinder base support.

6.0 Maintenance



IMPORTANT:

- Use only good quality hydraulic fluid. **Do NOT** use brake fluid, transmission fluid, turbine oil, motor oil, alcohol, glycerin etc. Use of anything other than good quality hydraulic oil will void warranty and damage the cylinder and application. We recommend Durapac Hydraulic Oil or equivalent
- Equipment must only be serviced by a qualified hydraulic technician. For repair service, contact your local Durapac authorized service center
- Damage to hydraulic hoses may not be detected during visual inspections. For this reason, Durapac recommends that hydraulic hoses be replaced on a regular basis
- Tighten connections as needed. Use non-hardening pipe thread compound when servicing connections

Dirt, sand, etc. will quickly ruin any hydraulic system. Ensure that couplings are clean and free of foreign matter. After each use, clean couplings and attach dust caps.

Maintenance is required when wear or leakage is noticed. Periodically inspect all components to detect any problem that may require service and maintenance.

- 6.1 Check for loose connections and leaks.
- 6.2 Replace damaged parts immediately.
- 6.3 Do not exceed oil temperature above 140°F.
- 6.4 Keep all hydraulic components clean.
- 6.5 Use dust caps when cylinder is disconnected from the hose. Keep entire cylinder clean to prolong cylinder life.
- 6.6 Wipe thoroughly clean and store cylinders upright (to prevent seal distortion) in a clean, dry environment. Avoid temperature extremes.
- 6.7 Change hydraulic oil in your system as recommended in the pump instruction sheet.

7.0 Troubleshooting

Problem	Cause	Solution
Cylinder moves but does not maintain pressure	Leaking connection	<ul style="list-style-type: none"> • Clean, reseal with thread sealant and tighten connection
	Leaking cylinder seals	<ul style="list-style-type: none"> • Replace worn seals • Check for excessive contamination or wear • Replace contaminated fluid as necessary
	Malfunctioning pump/valve	<ul style="list-style-type: none"> • Check pump or valve operating instructions • Repair or replace as necessary
Cylinder leaks hydraulic fluid	Worn or damaged seals	<ul style="list-style-type: none"> • Replace worn seals • Check for excessive contamination or wear • Replace contaminated fluid as necessary
	Loose connections	<ul style="list-style-type: none"> • Clean, reseal with thread sealant and tighten connection
Cylinder will not retract or retracts slower than normal	Closed pump release valve	<ul style="list-style-type: none"> • Open pump release valve
	Loose couplers	<ul style="list-style-type: none"> • Tighten couplers
	Blocked hydraulic lines	<ul style="list-style-type: none"> • Clean and flush lines
	Weak or broken retraction springs	<ul style="list-style-type: none"> • Send to a Durapac authorized service center for repair
	Internally damaged cylinder	<ul style="list-style-type: none"> • Send to a Durapac authorized service center for repair
	Pump reservoir too full	<ul style="list-style-type: none"> • Drain hydraulic fluid to correct level

Problem	Cause	Solution
Erratic Action	Air in system or pump cavitation	<ul style="list-style-type: none"> • Add fluid, bleed air and check for leaks
	External leakage	<ul style="list-style-type: none"> • Replace worn packings • Check for excessive contamination fluid as necessary • Replace contaminated fluid as necessary
	Sticking or binding cylinder	<ul style="list-style-type: none"> • Check for dirt or leaks • Check for bent, misaligned, worn parts or defective packings
Cylinder does not move	Loose couplers	<ul style="list-style-type: none"> • Tighten couplers
	Faulty coupler	<ul style="list-style-type: none"> • Verify that female coupler is not locked up (ball wedged into seat) • Replace both male and female couplers
	Improper valve position	<ul style="list-style-type: none"> • Close release valve or shift to new position
	Low or no hydraulic fluid in pump reservoir	<ul style="list-style-type: none"> • Fill and bleed the system
	Air-locked pump	<ul style="list-style-type: none"> • Prime pump according to pump operating instructions
	Pump not operating	<ul style="list-style-type: none"> • Check pump's operating instructions
	Load is above the capacity of the system	<ul style="list-style-type: none"> • Use the correct equipment
Cylinder extends only partially	Low or no hydraulic fluid in pump reservoir	<ul style="list-style-type: none"> • Fill and bleed the system
	Load is above the capacity of the system	<ul style="list-style-type: none"> • Use the correct equipment
	Sticking or binding cylinder	<ul style="list-style-type: none"> • Check for dirt or leaks • Check for bent, misaligned, worn parts or defective packings
Cylinder moves slower than normal	Loose couplers	<ul style="list-style-type: none"> • Tighten couplers
	Restricted hydraulic line or fitting	<ul style="list-style-type: none"> • Clean • Replace if damaged
	Pump not operating correctly	<ul style="list-style-type: none"> • Check pump's operating instructions • Repair or replace as necessary
	Low fluid level in pump reservoir	<ul style="list-style-type: none"> • Fill and bleed the system
	Leaking cylinder seals	<ul style="list-style-type: none"> • Replace worn seals • Check for excessive contamination or wear • Replace contaminated fluid as necessary

8.0 Parts Breakdown and List

8.1 Parts Breakdown – 12, 60 & 100 Ton Models & RHS-306

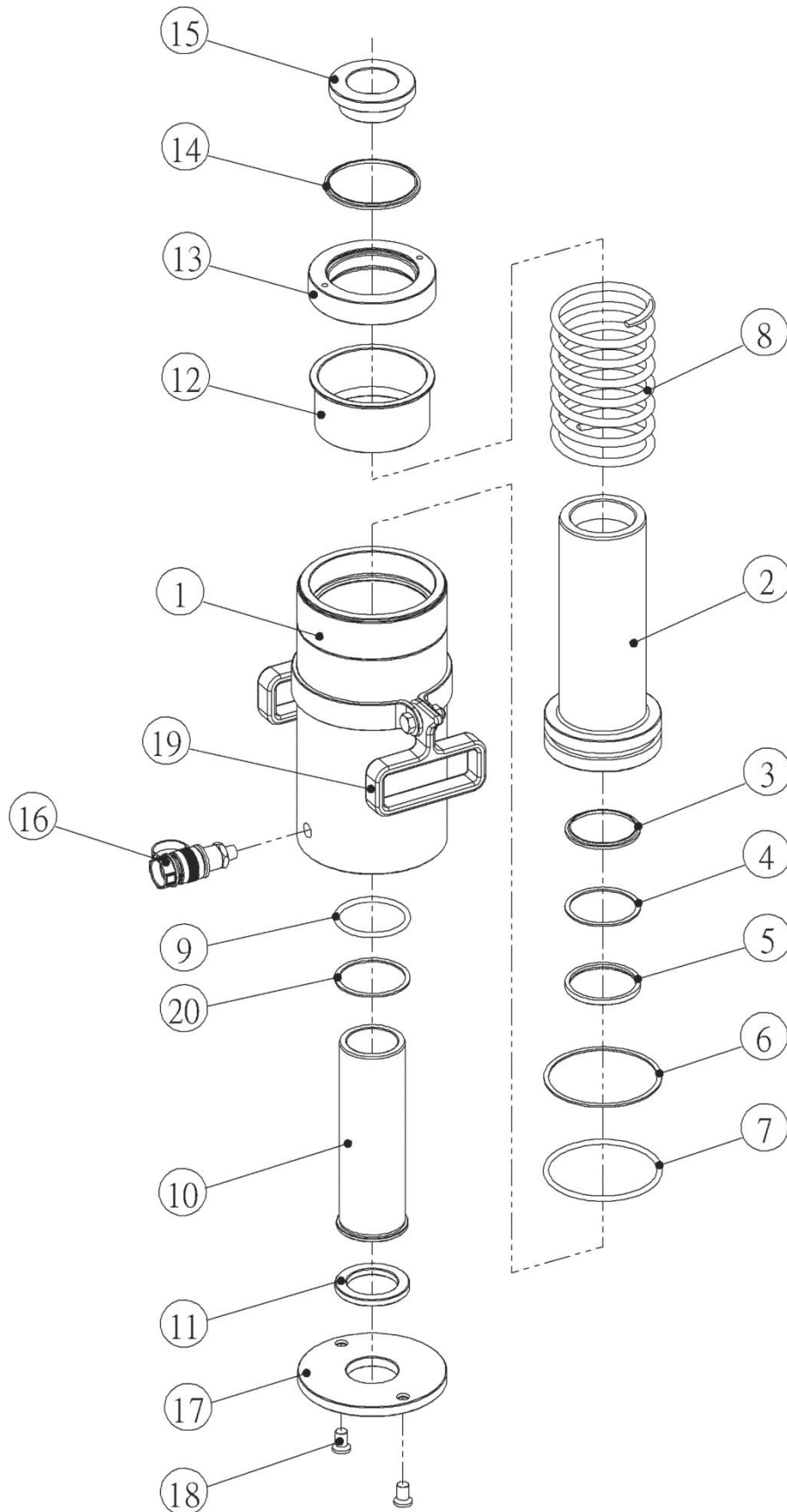

8.1.1 Cross Section - 12, 60 & 100 Ton Models & RHS-306

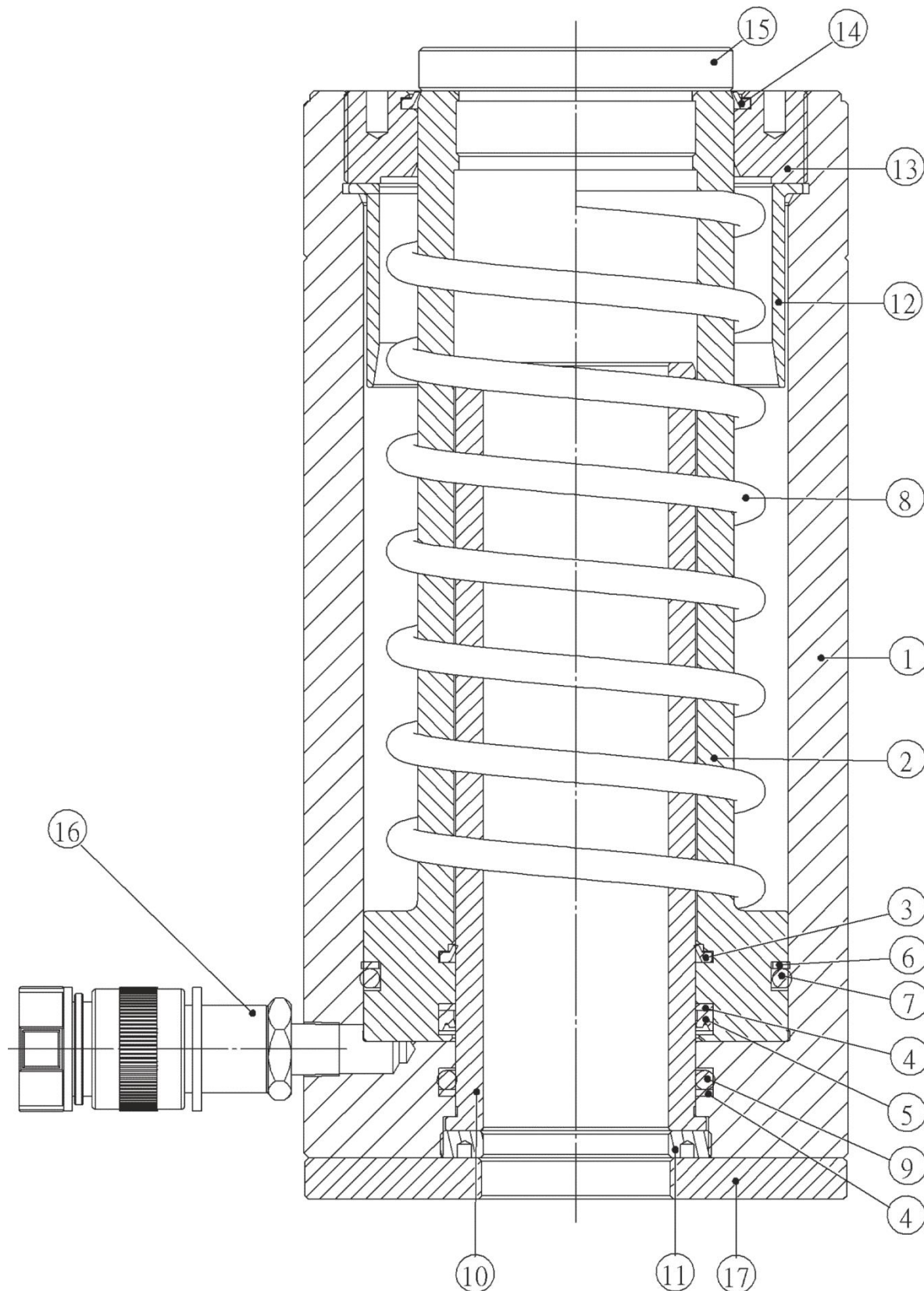

8.1.2 Parts Listing – 12, 60 & 100 Ton Models & RHS-306

Parts Listing - RHS-120			
Item	Description	Part No.	Qty
1	Cylinder	ZAM1542	1
2	Piston rod	ZAM1543	1
3	Wipers	-	-
4	Back-up ring*	ZAM1544	1
5	O-ring*	ZAM1545	1
6	Back-up ring*	ZAM1546	1
7	O-ring*	ZAM1547	1
8	Spring	ZAM1548	1
9	O-ring*	ZAM1545	1
10	Liner tube	ZAM1549	1
11	Base	-	-
12	Upper liner tube	-	-
13	Stop ring	ZAM1550	1
14	Wipers	-	-
15	Saddle	-	-
16	Coupler (set)	CR-6	1
	Whip hose (not shown)	ZAM1551	1
17	Lower saddle	ZAM1552	1
18	Bolt*	ZAM1553	2
19	Removable handle	-	-
20	Back-up ring*	ZAM1544	1
	Thread cap (not shown)	ZAM1232	1
	Repair kit	ZAM1097	1

Parts Listing - RHS-121			
Item	Description	Part No.	Qty
1	Cylinder	ZAM1554	1
2	Piston rod	ZAM1555	1
3	Wipers*	ZAM1556	1
4	Back-up ring*	ZAM1557	1
5	O-ring*	ZAM1558	1
6	Back-up ring*	ZAM1546	1
7	O-ring*	ZAM1547	1
8	Spring	ZAM1559	1
9	O-ring*	ZAM1558	1
10	Liner tube	ZAM1560	1
11	Base	ZAM1561	1
12	Upper liner tube	ZAM1592	1
13	Stop ring	ZAM1593	1
14	Wipers*	ZAM1594	1
15	Saddle	-	-
16	Coupler (set)	CR-6	1
17	Lower saddle	ZAM1552	1
18	Bolt*	ZAM1553	2
19	Handle	-	-
20	Back-up ring*	ZAM1557	1
	Thread cap (not shown)	ZAM1232	1
	Repair kit	ZAM1046	1

Parts Listing - RHS-1211			
Item	Description	Part No.	Qty
1	Cylinder	ZAM1554	1
2	Piston rod	ZAM1595	1
3	Wipers*	ZAM1556	1
4	Back-up ring*	ZAM1557	1
5	O-ring*	ZAM1558	1
6	Back-up ring*	ZAM1546	1
7	O-ring*	ZAM1547	1
8	Spring	ZAM1559	1
9	O-ring*	ZAM1558	1
10	Liner tube	ZAM1560	1
11	Base	ZAM1561	1
12	Upper liner tube	ZAM1592	1
13	Stop ring	ZAM1593	1
14	Wipers*	ZAM1594	1
15	Smooth saddle	-	-
16	Coupler (set)	CR-6	1
17	Lower saddle	ZAM1552	1
18	Bolt*	ZAM1553	2
19	Handle	-	-
20	Back-up ring*	ZAM1557	1
	Thread cap (not shown)	ZAM1232	1
	Repair kit	ZAM1046	1

Parts Listing - RHS-123

Item	Description	Part No.	Qty
1	Cylinder	ZAMM1614	1
2	Piston rod	ZAMM1648	1
3	Wipers*	ZAMM1556	1
4	Back-up ring*	ZAMM1557	1
5	O-ring*	ZAMM1558	1
6	Back-up ring*	ZAMM1546	1
7	O-ring*	ZAMM1547	1
8	Spring	ZAMM1649	1
9	O-ring*	ZAMM1558	1
10	Liner tube	ZAMM1650	1
11	Base	ZAMM1561	1
12	Upper liner tube	ZAMM1651	1
13	Stop ring	ZAMM1652	1
14	Wipers*	ZAMM1594	1
15	Saddle	-	-
16	Coupler (set)	CR-6	1
17	Lower saddle	ZAMM1552	1
18	Bolt*	ZAMM1553	2
19	Handle	-	-
20	Back-up ring*	ZAMM1557	1
	Thread cap (not shown)	ZAMM1232	1
	Repair kit	ZAMM1046	1

Parts Listing - RHS-306

Item	Description	Part No.	Qty
1	Cylinder	ZAMM1596	1
2	Piston rod	ZAMM1597	1
3	Wipers*	ZAMM1598	1
4	Back-up ring*	ZAMM1599	1
5	O-ring*	ZAMM1600	1
6	Back-up ring*	ZAMM1601	1
7	O-ring*	ZAMM1602	1
8	Spring	ZAMM1603	1
9	O-ring*	ZAMM1604	1
10	Liner tube	ZAMM1605	1
11	Base	ZAMM1606	1
12	Upper liner tube	ZAMM1607	1
13	Stop ring	ZAMM1608	1
14	Wipers*	ZAMM1609	1
15	Smooth saddle	ZAMM1610	1
15a	Optional Threaded Saddle	TSH-30	1
16	Coupler (set)	CR-6	1
17	Lower saddle	ZAMM1611	1
18	Bolt*	ZAMM1612	2
19	Handle	ZAMM1398	1
20	Back-up ring*	ZAMM1613	1
	Thread cap (not shown)	ZAMM1238	1
	Repair kit	ZAMM1048	1

Parts Listing - RHS-603

Item	Description	Part No.	Qty
1	Cylinder	ZAMM1248	1
2	Piston rod	ZAMM1647	1
3	Wipers*	ZAMM1401	1
4	Back-up ring*	ZAMM1402	1
5	O-ring*	ZAMM1403	1
6	Back-up ring*	ZAMM1615	1
7	O-ring*	ZAMM1616	1
8	Spring	ZAMM1617	1
9	O-ring*	ZAMM1618	1
10	Liner tube	ZAMM1619	1
11	Base	ZAMM1409	1
12	Upper liner tube	ZAMM1410	1
13	Stop ring	ZAMM1411	1
14	Wipers*	ZAMM1412	1
15	Smooth saddle	ZAMM1413	1
15a	Optional Threaded Saddle	TSH-60	1
16	Coupler (set)	CR-6	1
17	Lower saddle	ZAMM1414	1
18	Bolt*	ZAMM1415	2
19	Removable handle	ZAMM1416	1
20	Back-up ring*	ZAMM1402	1
	Thread cap (not shown)	ZAMM1239	1
	Repair kit	ZAMM1049	1

Parts Listing - RHS-604

Item	Description	Part No.	Qty
1	Cylinder	ZAM1620	1
2	Piston rod	ZAM1622	1
3	Wipers*	ZAM1401	1
4	Back-up ring*	ZAM1402	1
5	O-ring*	ZAM1403	1
6	O-ring*	ZAM1616	1
7	Back-up ring*	ZAM1615	1
8	Spring	ZAM1623	1
9	O-ring*	ZAM1618	1
10	Liner tube	ZAM1621	1
11	Base	ZAM1409	1
12	Upper liner tube	ZAM1624	1
13	Stop ring	ZAM1411	1
14	Wipers*	ZAM1412	1
15	Smooth saddle	ZAM1413	1
15a	Optional Threaded Saddle	TSH-60	1
16	Coupler (set)	CR-6	1
17	Lower saddle	ZAM1414	1
18	Bolt*	ZAM1415	2
19	Removable handle	ZAM1416	1
20	Back-up ring*	ZAM1402	1
	Thread cap (not shown)	ZAM1239	1
	Repair kit	ZAM1049	1

Parts Listing - RHS-606

Item	Description	Part No.	Qty
1	Cylinder	ZAM1399	1
2	Piston rod	ZAM1400	1
3	Wipers*	ZAM1401	1
4	Back-up ring*	ZAM1402	1
5	O-ring*	ZAM1403	1
6	Back-up ring*	ZAM1615	1
7	O-ring*	ZAM1616	1
8	Spring	ZAM1406	1
9	O-ring*	ZAM1618	1
10	Liner tube	ZAM1408	1
11	Base	ZAM1409	1
12	Upper liner tube	ZAM1410	1
13	Stop ring	ZAM1411	1
14	Wipers*	ZAM1412	1
15	Smooth saddle	ZAM1413	1
15a	Optional Threaded Saddle	TSH-60	1
16	Coupler (set)	CR-6	1
17	Lower saddle	ZAM1414	1
18	Bolt*	ZAM1415	2
19	Removable handle	ZAM1416	1
20	Back-up ring*	ZAM1402	1
	Thread cap (not shown)	ZAM1239	1
	Repair kit	ZAM1049	1

Parts Listing - RHS-1003

Item	Description	Part No.	Qty
1	Cylinder	ZAM1625	1
2	Piston rod	ZAM1626	1
3	Wipers*	ZAM1627	1
4	Back-up ring*	ZAM1628	1
5	O-ring*	ZAM1629	1
6	Back-up ring*	ZAM1516	1
7	O-ring*	ZAM1517	1
8	Spring	ZAM1630	1
9	O-ring*	ZAM1629	1
10	Liner tube	ZAM1632	1
11	Base	ZAM1633	1
12	Upper liner tube	ZAM1634	1
13	Stop ring	ZAM1635	1
14	Wipers*	ZAM1636	1
15	Smooth saddle	ZAM1637	1
15a	Optional Threaded Saddle	TSH-100	1
16	Coupler (set)	CR-6	1
17	Lower saddle	ZAM1638	1
18	Bolt*	ZAM1639	2
19	Removable handle	ZAM1640	1
20	Back-up ring*	ZAM1628	1
	Thread cap (not shown)	ZAM1240	1
	Repair kit	ZAM1045	1

Parts Listing - RHS-1006

Item	Description	Part No.	Qty
1	Cylinder	ZAM1642	1
2	Piston rod	ZAM1644	1
3	Wipers*	ZAM1627	1
4	Back-up ring*	ZAM1628	1
5	O-ring*	ZAM1629	1
6	O-ring*	ZAM1517	1
7	Back-up ring*	ZAM1516	1
8	Spring	ZAM1645	1
9	O-ring*	ZAM1629	1
10	Liner tube	ZAM1643	1
11	Base	ZAM1633	1
12	Upper liner tube	ZAM1646	1
13	Stop ring	ZAM1635	1
14	Wipers*	ZAM1636	1
15	Smooth saddle	ZAM1637	1
15a	Optional Threaded Saddle	TSH-100	1
16	Coupler (set)	CR-6	1
17	Lower saddle	ZAM1638	1
18	Bolt*	ZAM1639	2
19	Removable handle	ZAM1640	1
20	Back-up ring*	ZAM1628	1
	Thread cap (not shown)	ZAM1240	1
	Repair kit	ZAM1045	1

8.2 Parts Breakdown – 20 and 30 Ton Models (excluding RHS-306)

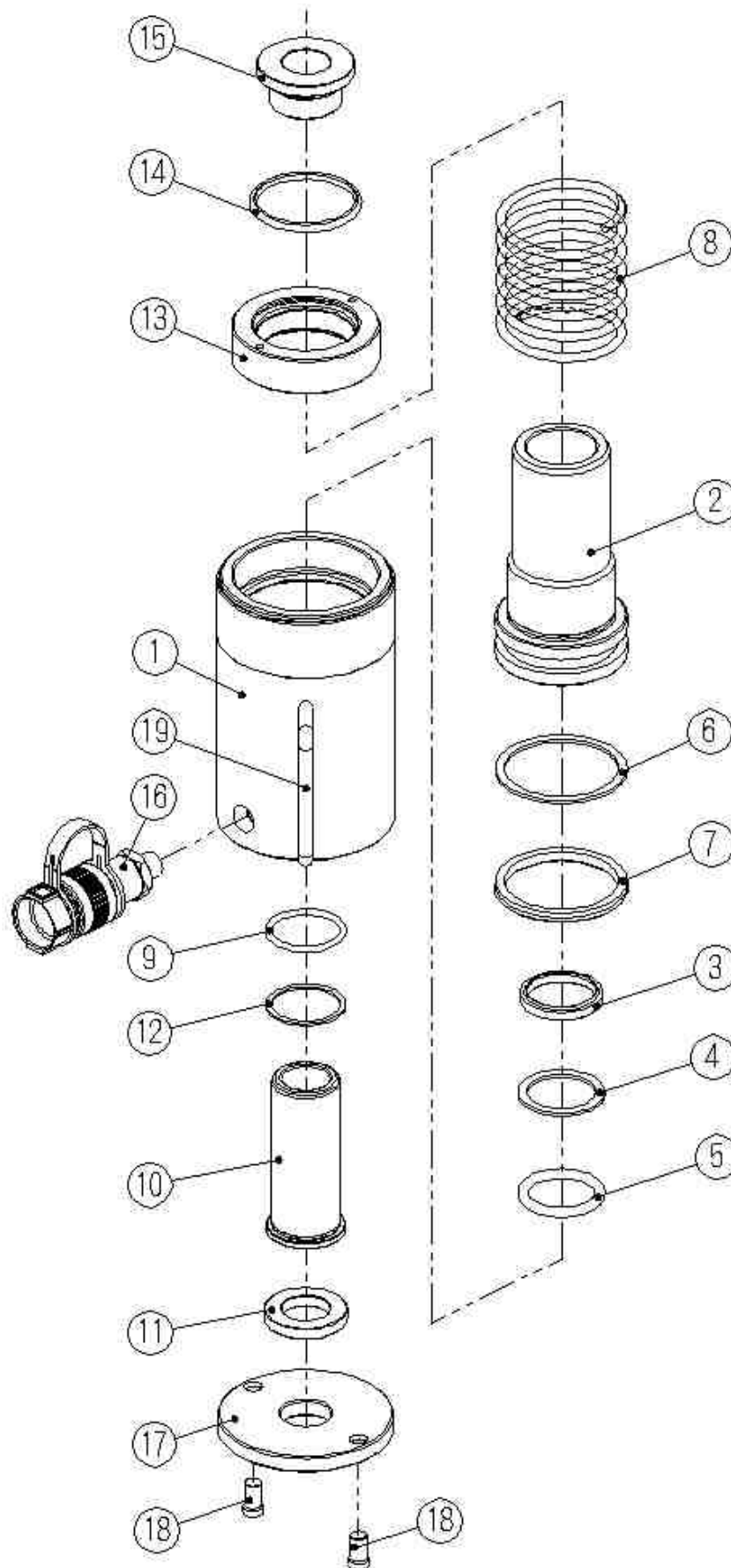

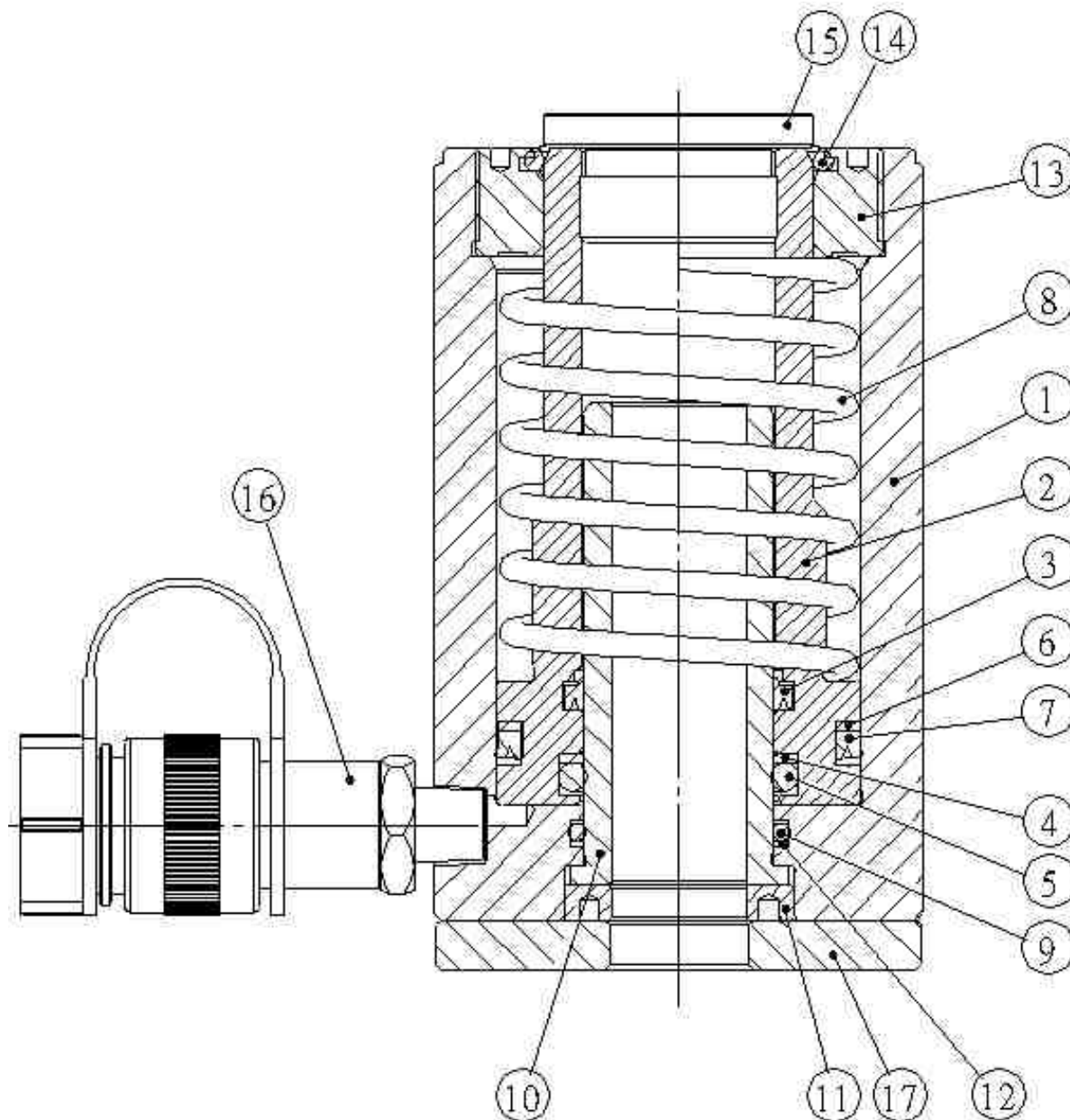
8.2.1 Cross Section - 20 and 30 Ton Models (excluding RHS-306)

8.2.2 Parts Listing - 20 & 30 Ton Models (excluding RHS-306)

Parts Listing - RHS-202			
Item	Description	Part No.	Qty
1	Cylinder	ZAM1641	1
2	Piston rod	ZAM1662	1
3	Wipers*	ZAM1383	1
4	Back-up ring*	ZAM1384	1
5	O-ring*	ZAM1385	1
6	Back-up ring*	ZAM1386	1
7	O-ring*	ZAM1387	1
8	Spring	ZAM1663	1
9	O-ring*	ZAM1389	1
10	Liner tube	ZAM1664	1
11	Base	ZAM1391	1
12	Back-up ring*	ZAM1392	1
13	Stop ring	ZAM1665	1
14	Wipers*	ZAM1394	1
15	Smooth Saddle	ZAM1395	1
15a	Optional Threaded Saddle	TSH-20	1
16	Coupler (set)	CR-6	1
17	Lower saddle	ZAM1396	1
18	Bolt*	ZAM1397	2
19	Handle	ZAM1666	1
	Thread cap (not shown)	ZAM1237	1
	Repair kit	ZAM1047	1

Parts Listing - RHS-204			
Item	Description	Part No.	Qty
1	Cylinder	ZAM1381	1
2	Piston rod	ZAM1382	1
3	Wipers*	ZAM1383	1
4	Back-up ring*	ZAM1384	1
5	O-ring*	ZAM1385	1
6	Back-up ring*	ZAM1386	1
7	O-ring*	ZAM1387	1
8	Spring	ZAM1388	1
9	O-ring*	ZAM1389	1
10	Liner tube	ZAM1390	1
11	Base	ZAM1391	1
12	Back-up ring*	ZAM1392	1
13	Stop ring	ZAM1393	1
14	Wipers*	ZAM1394	1
15	Smooth Saddle	ZAM1395	1
16	Coupler (set)	CR-6	1
17	Lower saddle	ZAM1396	1
18	Bolt*	ZAM1397	2
19	Handle	ZAM1398	1
	Thread cap (not shown)	ZAM1237	1
	Repair kit	ZAM1047	1

Parts Listing - RHS-206			
Item	Description	Part No.	Qty
1	Cylinder	ZAM1667	1
2	Piston rod	ZAM1668	1
3	Wipers*	ZAM1383	1
4	Back-up ring*	ZAM1384	1
5	O-ring*	ZAM1385	1
6	Back-up ring*	ZAM1386	1
7	O-ring*	ZAM1387	1
8	Spring	ZAM1669	1
9	O-ring*	ZAM1389	1
10	Liner tube	ZAM1251	1
11	Base	ZAM1391	1
12	Back-up ring*	ZAM1392	1
13	Stop ring	ZAM1393	1
14	Wipers*	ZAM1394	1
15	Smooth Saddle	ZAM1395	1
15a	Optional Threaded Saddle	TSH-20	1
16	Coupler (set)	CR-6	1
17	Lower saddle	ZAM1396	1
18	Bolt*	ZAM1397	2
19	Handle	ZAM1398	1
	Thread cap (not shown)	ZAM1237	1
	Repair kit	ZAM1047	1

Parts Listing - RHS-302			
Item	Description	Part No.	Qty
1	Cylinder	ZAM1670	1
2	Piston rod	ZAM1671	1
3	Wipers*	ZAM1598	1
4	Back-up ring*	ZAM1599	1
5	O-ring*	ZAM1600	1
6	Back-up ring*	ZAM1601	1
7	O-ring*	ZAM1602	1
8	Spring	ZAM1672	1
9	O-ring*	ZAM1604	1
10	Liner tube	ZAM1673	1
11	Base	ZAM1606	1
12	Back-up ring*	ZAM1613	1
13	Stop ring	ZAM1674	1
14	Wipers*	ZAM1609	1
15	Smooth Saddle	ZAM1610	1
15a	Optional Threaded Saddle	TSH-30	1
16	Coupler (set)	CR-6	1
17	Lower saddle	ZAM1611	1
18	Bolt*	ZAM1612	2
19	Handle	ZAM1675	1
	Thread cap (not shown)	ZAM1238	1
	Repair kit	ZAM1048	1

Parts Listing - RHS-304			
Item	Description	Part No.	Qty
1	Cylinder	ZAM1676	1
2	Piston rod	ZAM1677	1
3	Wipers*	ZAM1598	1
4	Back-up ring*	ZAM1599	1
5	O-ring*	ZAM1600	1
6	Back-up ring*	ZAM1601	1
7	O-ring*	ZAM1602	1
8	Spring	ZAM1678	1
9	O-ring*	ZAM1604	1
10	Liner tube	ZAM2598	1
11	Base	ZAM1606	1
12	Back-up ring*	ZAM1613	1
13	Stop ring	ZAM1608	1
14	Wipers*	ZAM1609	1
15	Smooth Saddle	ZAM1610	1
16	Coupler (set)	CR-6	1
17	Lower saddle	ZAM1611	1
18	Bolt*	ZAM1612	2
19	Handle	ZAM1398	1
	Thread cap (not shown)	ZAM1238	1
	Repair kit	ZAM1048	1

Items marked with a * are contained within a standard seal kit.
Part, serial and model numbers need to be quoted when ordering parts.